

Home & Garden Range



One range of quality pumps for
the Home, Garden and Farm

be
think
innovate

GRUNDFOS 

Working it out

WHAT PUMP DO I NEED? 1

Application	Household water supply
	Drainage
	Irrigation
	Water transfer
	Other
Water source	Above ground tank
	Underground tank
	River
	Dam
	Other
Power supply	240 V single phase
	415 V three phase
Water requirement	Household
	House only
	House and garden
	Showers (number)
	Sprinklers (number)
	Sprinklers (type)
	Evaporative airconditioner connected
	Irrigation
	Sprinklers (number)
	Sprinklers (type)
	Automatic Operation
	Manual Operation
	Drainage and Water transfer
	Lift from pump (A) to point of discharge (B)
Details of existing pipeline	Size (mm)
	Type (Polyethylene/PVC/Copper/Steel)
	Length (m)

HOW MUCH FLOW (Q)? 2

Water pressure systems	✓	
Weekend cottage		10 to 20 L/min
Small home		20 to 30 L/min
Average home		30 to 50 L/min
Large home		50 to 90 L/min
Average water consumption	No.	
Standard shower head		15 L/min
Water saving shower head		6-7 L/min
Household standard tap		10-15 L/min
Tap with aerator or flow restrictor		4-6 L/min
Lawn sprinkler		10-15 L/min
Drainage and effluent		See your Grundfos dealer

CALCULATE THE FLOW RATE 3

$$Q = (\quad) \text{ L/min}$$

HOW MUCH PRESSURE (P)? 4

P = Pump Head

Hd = Height difference between the pump and the highest point of use

Hs = Pressure already available at the pump level (tank example with positive suction head). If you pump water under the level of the pump (well, river, underground tank), contact your Dealer in order to calculate the suction lift and to select the right pump

Hf = Friction loss or pipe resistance to water flow (see page 48)

Pr = Residual pressure, i.e. the required pressure at the tap, shower or sprinkler. As a guide, shower head, standard ½" tap or sprinkler requires approx. 150 kPa (15 m or 21 psi)

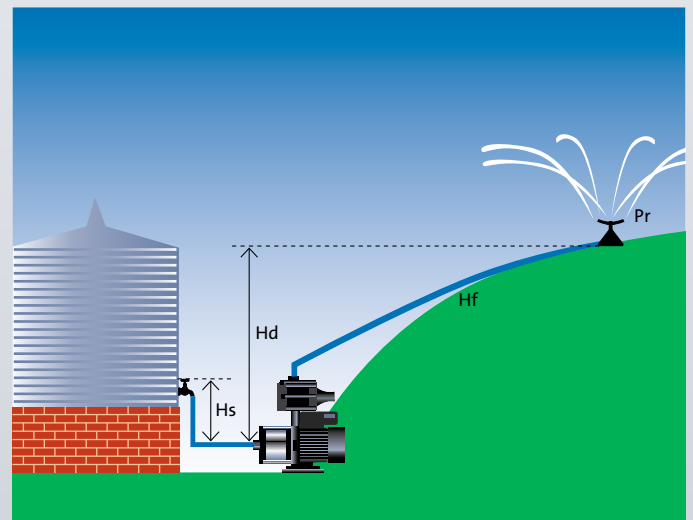

CALCULATE THE PRESSURE 5

$$P = (\quad) Hd - (\quad) Hs + (\quad) Hf + (\quad) Pr$$

Example

Q (Flow rate) = 60 L/min = 4 (sprinklers) x 15 L/min

Hs = 2 m

Hd = 15 m

Hf = 3.6 m

(50 m of 40 mm Poly Pipe - see Friction Loss Chart, page 48)

Pr = 15 m (150 kPa)

P = 15 - 2 + 3.6 + 15 = 31.6 m = 310 kPa = 44 psi

Index

Product pages

CME Booster	3	UNILIFT CC	31
CM Booster Self-Priming	5	UNILIFT KP	33
CM-PS	7	UNILIFT AP 12	35
CMBasic	9	UNILIFT AP 35 & 50	37
JP, PM	11	UNILIFT AP 35B & 50B	39
JPRain	13	SOLOLIFT 2	41
JP Basic	15	UPA	43
Pressure Manager	17	COMFORT PM	44
PM Rain	19	UPS(N)	45
Pressure Tanks	21	ALPHA 2(N)	46
SB	23		
SBA	25		
SQN (E)	27		
SP A	29		
		General	
		Engineering Data	47

CME Booster



The Grundfos CME Booster is a compact, frequency controlled booster designed for a variety of domestic and light industrial applications. The CME Booster ensures great comfort by providing constant pressure regardless of variations in demand or inlet pressure.



Features

Robust design

All wetted parts are made from high quality stainless steel to ensure the longest life possible.

Energy saving

The frequency controller of the CME Booster matches the power consumption with the required water output, helping to conserve energy.

Easy installation

The CME Booster is very easy to install. Once the booster has been connected to the pipework, it is simply a matter of putting the plug into a socket, and the system is operational.

Quiet operation

The CME Booster operates quietly, at around 55 decibels, significantly quieter than most pumps currently available on the market.

User-friendly interface

The user-friendly interface features LED indicators showing operational status and buttons for pressure adjustment.

Protective features

The CME Booster features dry run protection to automatically stop the pump if the water source runs out. The pump is also protected against any accidental overload by built-in thermal protection. These protective features help to ensure the longest life possible.

Applications

- Mains boosting
- Household water supply
- Pressure boosting from above ground water tanks
- Light industrial use



Performance

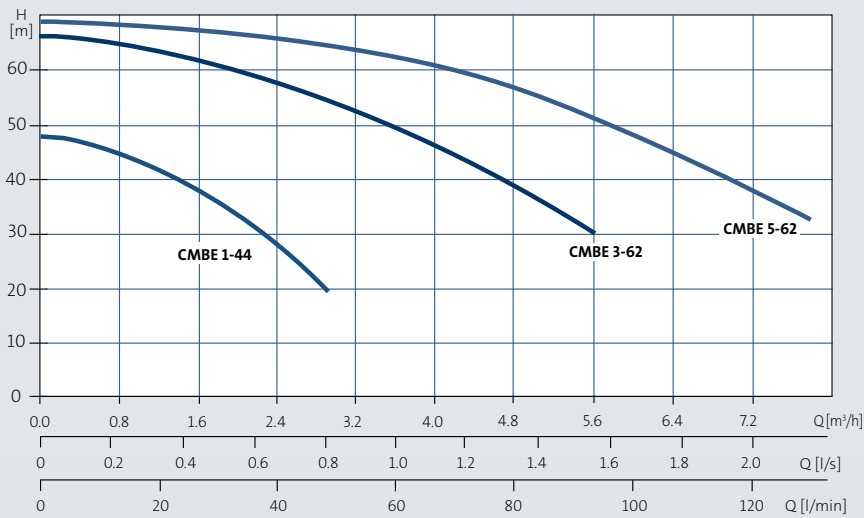

Operating Conditions

System pressure

Max. 10 bar

Liquid temperature

0 °C to 60 °C

Ambient temperature

Max. 55 °C

Relative air humidity

Max. 95 %

Technical Data

Mains voltage

1 x 240 V, 50 Hz

Enclosure class

IP55

Insulation class

F

Sound pressure level

< 55 dB

Approvals and markings

ASNZ4020, CE

Dimensions

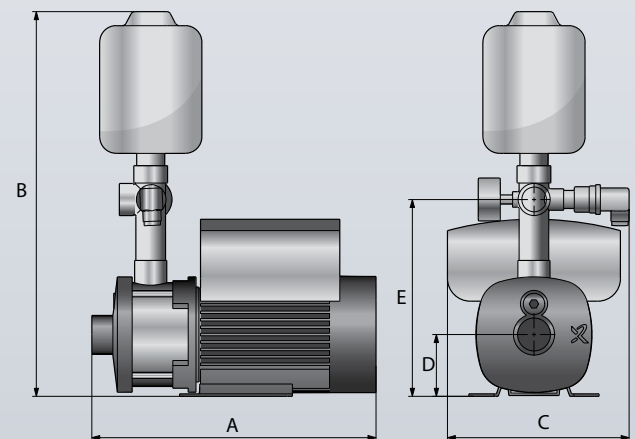

Model	Power (kW)	Connections		Dimensions (mm)					Weight (kg)
		Outlet	Inlet	A	B	C	D	E	
CMBE 1-44	0.55	1" F	1" F	345	467	221	75	239	16.1
CMBE 3-62	1.1	1" F	1" F	345	467	221	75	239	17.4
CMBE 5-62	1.5	1¼" F	1¼" F	345	467	221	75	239	18.8

CM Booster Self-Priming



The Grundfos CM Booster Self-Priming is a compact booster pump designed for domestic and light industrial use. The booster unit consists of a robust multistage centrifugal pump and a generator friendly PM1 or PM2 Pressure Manager. The Pressure Manager allows the pump to start and stop automatically according to demand and protects the pump from dry running. The CM Booster Self-Priming is the perfect solution if you are struggling with insufficient mains pressure, and can also be used with above or below ground water sources.



Features

Self-priming

With a suction lift of up to 8 metres (self-priming up to 4 metres), the CM Booster Self-Priming is ideal for pressurising water from above or below ground water sources.

Robust design

All wetted parts are made from high quality, corrosion resistant stainless steel to ensure the longest life possible.

User-friendly interface

The pump features a user-friendly interface with LED indicators displaying power status, pump running, alarm indication and pressure indication (excluding CMB-SP 1-36).

Protective features

The pump incorporates a range of protective features such as; dry run protection, thermal overload protection, cycling alarm and maximum continuous operation time - 30 mins (excluding CMB-SP 1-36) to protect the pump and ensure a long life.

Easy installation

The booster unit is a compact and adaptable solution, which makes it suitable for most installations. Simply connect the inlet and outlet and adjust the start pressure to suit individual requirements and you have a fully operational booster unit.

Integrated non-return valve

Non-return valve for backflow prevention.

Applications

- Mains boosting
- Household water supply
- Boosting from above ground water tanks
- Boosting from below ground water sources e.g. below ground tank/dam
- Light industrial use



CM Booster Self-Priming

Performance

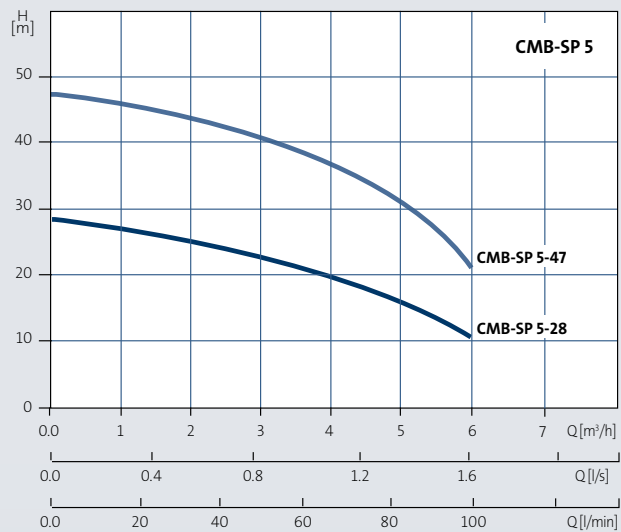
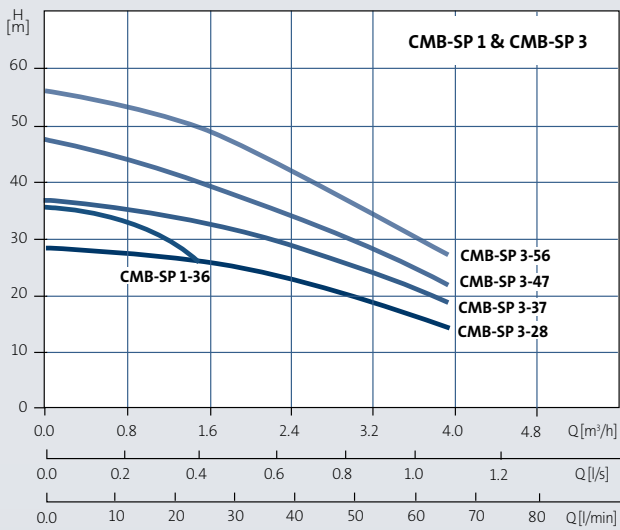

Operating Conditions

System pressure

Max. 10 bar

Liquid temperature

0 °C to 60 °C

Ambient temperature

Max. 55 °C

Relative air humidity

Max. 95 %

Technical Data

Mains voltage

1 x 240 V, 50 Hz

Enclosure class

IP55

Insulation class

F

Sound pressure level

55 dB

Start/stop frequency

Max. 100 per hour

Approvals and markings

ASNZ4020, CE

Dimensions

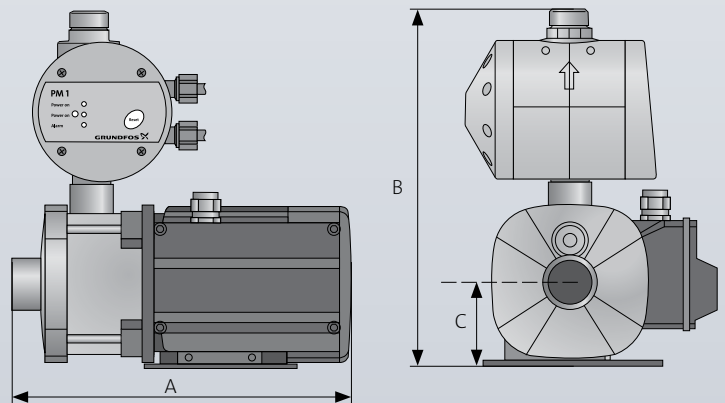

Model	Power (kW)	Connections		Dimensions (mm)			Weight (kg)
		Outlet	Inlet	A	B	C	
CMB-SP 1-36	0.5	1" M	1" F	377	317	75	14.1
CMB-SP 3-28	0.5	1" M	1" F	377	317	75	13.7
CMB-SP 3-37	0.5	1" M	1" F	377	317	75	14.1
CMB-SP 3-47	0.5	1" M	1" F	413	317	75	14.4
CMB-SP 3-56	0.67	1" M	1" F	453	317	75	16.4
CMB-SP 5-28	0.5	1" M	1" F	377	317	75	13.7
CMB-SP 5-47	0.9	1" M	1" F	453	317	75	16.9



The CM-PS is a compact booster solution designed for domestic and light industrial use. The booster unit consists of a robust CM pump, 5-way valve and a pressure switch. To complete the booster system a pressure tank must be fitted. The pressure switch and pressure tank ensure a convenient water supply with a minimum start/stop frequency.



Features

Robust design

All wetted parts are made from high quality stainless steel including the impeller, pump housing and shaft to ensure the longest life possible.

Automatic operation

The built-in pressure switch automatically starts and stops the pump according to demand.

Easy installation

The booster unit is a compact solution, which makes it suitable for most installations. Simply connect your own pressure tank, inlet and outlet, and you have a fully operational booster unit.

Great system comfort

The diaphragm tank increases system comfort by limiting the switching frequency of the pump and compensating for pressure drops when a tap is opened. It also reduces problems with water hammer in the pipework.

Motor protection

The single-phase CM pump is effectively protected against any accidental overload, by built-in thermal and current protection. This means that no additional motor protection is required.

Applications

- Mains boosting
- Boosting from above ground water tanks



Performance

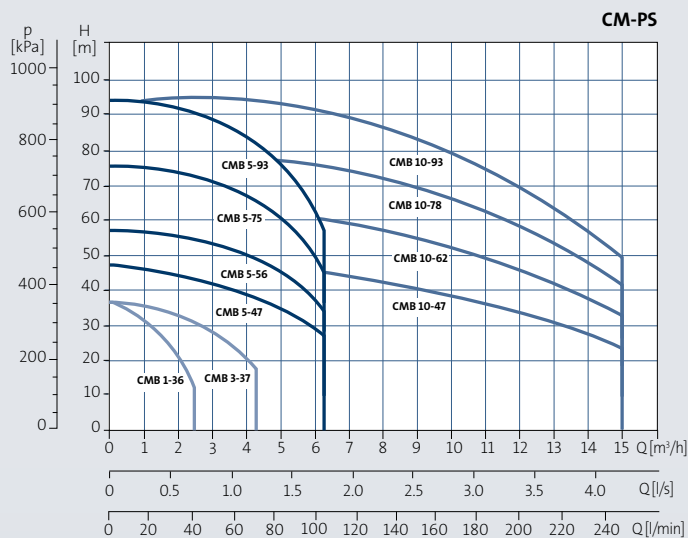

Dimensions

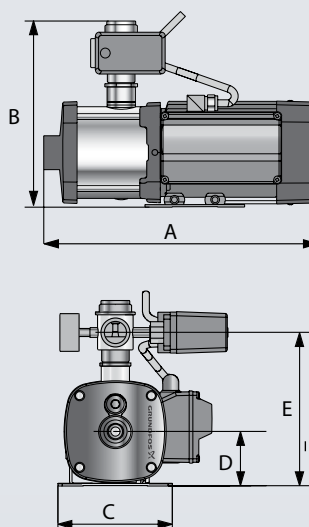

Operating Conditions

System pressure

Max. 10 bar

Liquid temperature

0 °C to 60 °C

Ambient temperature

Max. 60 °C

Relative air humidity

Max. 95 %

Technical Data

Mains voltage

1 x 240 V, 50 Hz

3 x 415 V, 50 Hz

Enclosure class

IP55

Insulation class

F

Sound pressure level

50-60 dB

Start/stop frequency

Max. 100 per hour

Approvals and markings

AS/NZ4020, CE

Model	Power (kW)	Connections		Dimensions (mm)					Weight (kg)
		Outlet	Inlet	A	B	C	D	E	
CMB 1-36	0.5	1" F	1" F	323	255	158	75	208	18.0
CMB 3-37	0.5	1" F	1" F	323	255	158	75	208	18.0
CMB 5-47	0.9	1" F	1¼" F	381	255	158	75	208	20.7
CMB 5-56	1.3	1" F	1¼" F	466.5	270	178	90	223	27.6
CMB 5-75	1.3	1" F	1¼" F	502.5	270	178	90	223	30.0
CMB 5-93	1.9	1" F	1¼" F	538.5	270	178	90	223	31.0
CMB 10-47	1.9	1½" F	1½" F	450	323	199	100	261	33.5
3 x 415 V, 50 Hz									
CMB 5-47	1.2	1" F	1¼" F	255	75	208	401	158	22.0
CMB 5-56	1.2	1" F	1¼" F	255	75	208	437	158	22.3
CMB 5-75	1.58	1" F	1¼" F	270	90	223	502.5	178	30.0
CMB 5-93	2.2	1" F	1¼" F	270	90	223	578.5	178	31.0
CMB 10-47	2.2	1½" F	1½" F	323	100	261	490	199	33.0
CMB 10-62	3.2	1½" F	1½" F	323	100	261	537	199	36.0
CMB 10-78	3.2	1½" F	1½" F	323	100	261	597	199	36.0
CMB 10-93	4	1½" F	1½" F	323	100	261	597	199	39.0

Model	Connection Size (mm)	Capacity (L)	Mounting type	Max pressure (kPa)
GT-H-18 PN10 G1 V	1" M	18	Pipe	1000
GT-H-18 PN16 G1 V	1" M	18	Pipe	1600
GT-H-60 PN10 G1 V	1" F	60	Free standing	1000
GT-H-80 PN10 G1 V	1" F	80	Free standing	1000
GT-H-80 PN16 G1 V	1" F	80	Free standing	1600
GT-H-100 PN10 G1 V	1" F	100	Free standing	1000
GT-D-130 PN10 G1 V	1" F	130	Free standing	1000
GT-D-200 PN10 G1 1/4 V	1¼" F	170	Free standing	1000
GT-D-240 PN10 G1 1/4 V	1¼" F	240	Free standing	1000
GT-D-300 PN10 G1 1/4 V	1¼" F	300	Free standing	1000
GT-D-450 PN10 G1 1/4 V	1¼" F	450	Free standing	1000

Note: Recommended tank size is dependant on application. To avoid rapid cycling Grundfos recommends the following tank sizes:

CM1 > 80 L

CM3 > 200 L

CM5 > 300 L

CM10 - 450 L

CMBasic



The Grundfos CMBasic is a compact booster pump designed for domestic and light industrial use. The booster unit consists of a Grundfos CM cast iron pump with stainless steel hydraulic components and PM1 Pressure Manager. The Pressure Manager allows the pump to start and stop automatically according to demand and protects the pump from dry running.



Features

Robust design

All moving parts are made from high quality, corrosion resistant stainless steel to ensure the longest life possible.

User-friendly interface

The pump features a user-friendly interface with LED indicators displaying power status, pump running, and alarm indication.

Protective features

The pump incorporates a range of protective features such as dry run protection, thermal overload protection, cycling alarm and maximum continuous operation time - 30 mins (excluding CMBasic 1-36) to protect the pump and ensure a long life.

Easy installation

The booster unit is a compact solution, which makes it suitable for most installations. Simply connect the inlet and outlet and you have a fully operational booster unit.

Integrated non-return valve

Non-return valve for backflow prevention.

Applications

- Mains boosting
- Household water supply
- Boosting from above ground water tanks
- Light industrial use



Performance

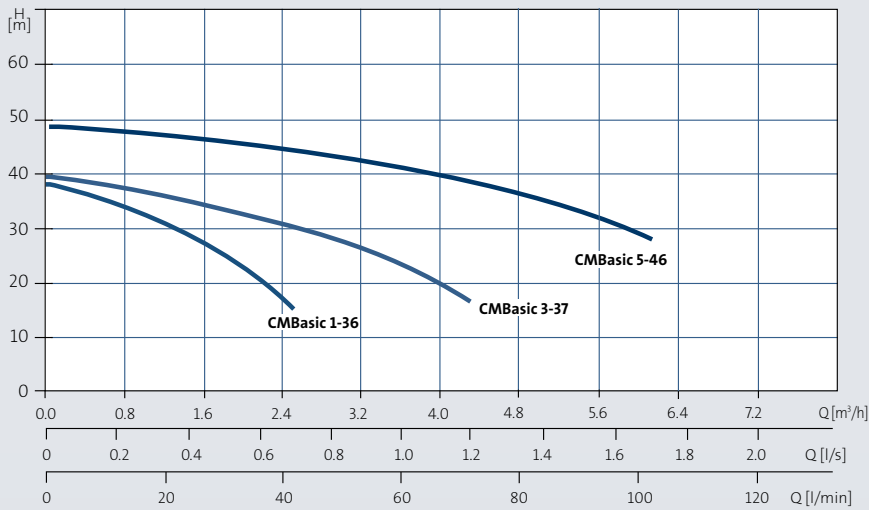

Operating Conditions

System pressure

Max. 10 bar

Liquid temperature

0 °C to 60 °C

Ambient temperature

Max. 55 °C

Relative air humidity

Max. 95 %

Technical Data

Mains voltage

1 x 240 V, 50 Hz

Enclosure class

IP55

Insulation class

F

Sound pressure level

50-60 dB

Start/stop frequency

Max. 100 per hour

Approvals and markings

CE

Dimensions

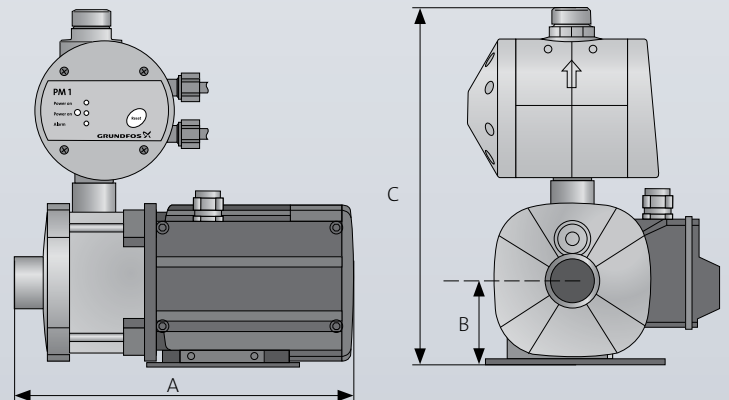

Model	Power (kW)	Connections		Dimensions (mm)			Weight (kg)
		Outlet	Inlet	A	B	C	
CMBasic 1-36	0.5	1" M	1" F	323	75	317	13.3
CMBasic 3-37	0.5	1" M	1" F	323	75	317	13.3
CMBasic 5-46	0.9	1" M	1¼" F	381	75	317	16.0

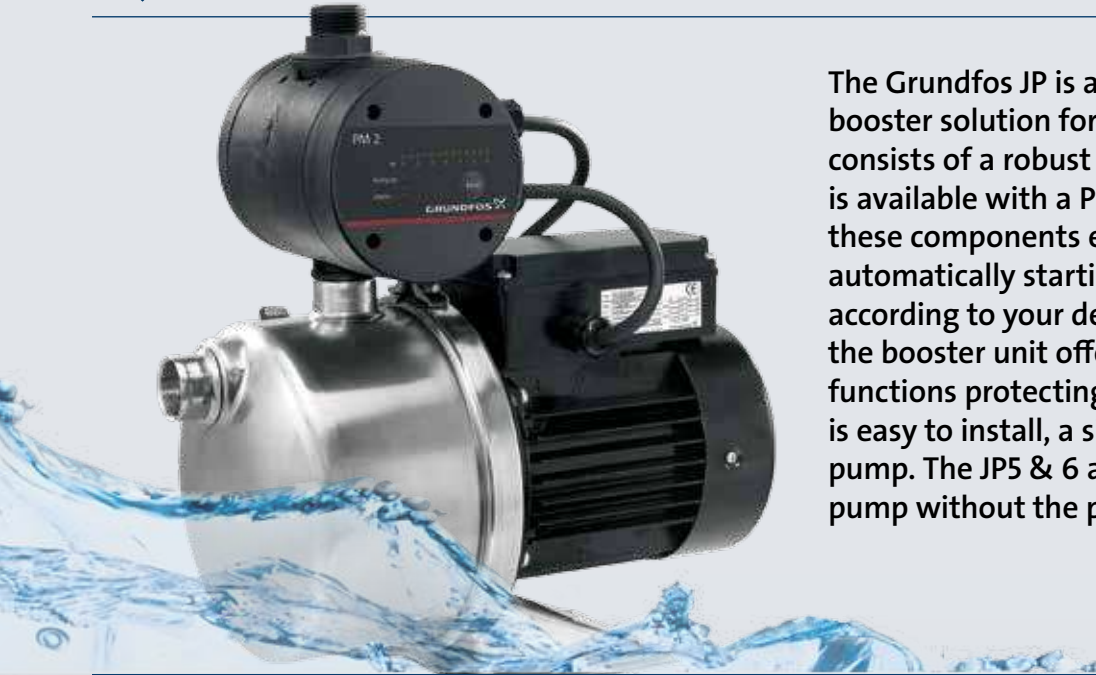

The Grundfos JP is a compact self-priming booster solution for domestic water supply. It consists of a robust single-stage jet pump and is available with a Pressure Manager. Together these components ensure great comfort by automatically starting and stopping the pump according to your demand. Furthermore, the booster unit offers integrated protective functions protecting your investment. The JP is easy to install, a simple matter of plug and pump. The JP5 & 6 are also available as a bare pump without the pressure manager.



Features

Self-priming

With a suction-lift up to 7 metres, this booster unit is ideal for pumping from below ground level. This feature makes the booster unit suitable for a large variety of installations.

Robust design

The pump is made with materials that ensure excellent corrosion resistance. The pump housing and impeller are made of high quality stainless steel, while the rest of the pump is electrophoretically painted.

User-friendly interface

The booster versions includes a user-friendly interface with LED indicators which shows, power on, pump running and alarm indication.

Protective features

The Pressure Manager incorporates features to protect both the pump and installation including dry running protection and cycling alarm.

Easy installation

The booster unit is a compact solution, which makes it suitable for most installations. Simply connect the inlet and outlet and you have a fully operational booster unit.

Integrated non-return valve

No additional fittings required for an above ground tank installation.

Applications

- Below and above ground water source with a suction lift up to 7 metres



Performance

JP 5 and JP 6

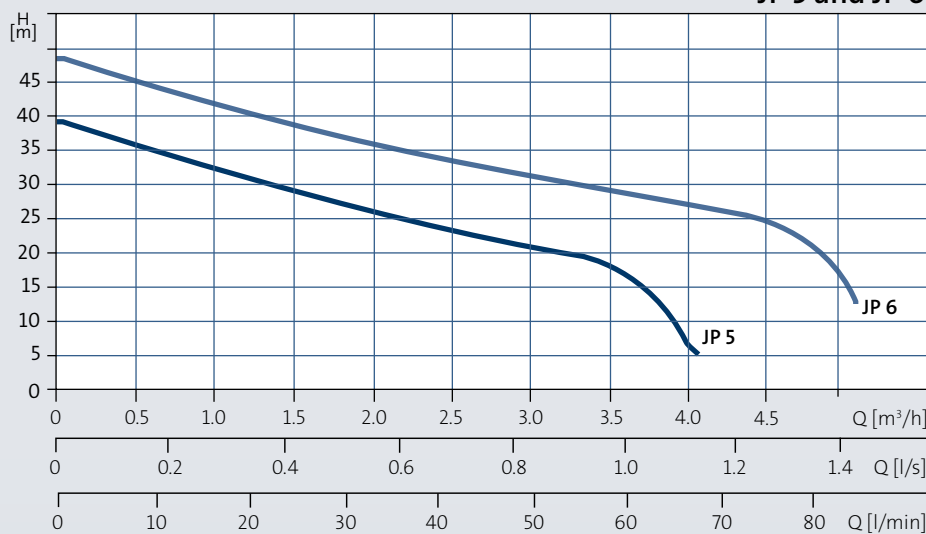

Operating Conditions

System pressure

Max. 6 bar

Suction lift

Max. 7 metres, including suction pipe pressure loss at a liquid temperature of 20 °C

Liquid temperature

0 °C to 40 °C

Ambient temperature

-20 °C to 45 °C

Relative air humidity

Max. 95 %

Dimensions

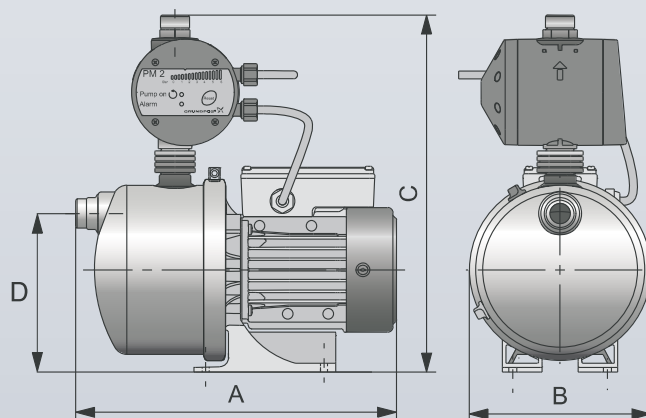

Technical Data

Mains voltage

1 x 240 V, 50 Hz (JP Booster PM)

Enclosure class

IP44

Insulation class

F

Sound pressure level

72 dB

Start/stop frequency

Max. 100 per hour

Approvals and markings

CE, C-tick, GHOST TR

Model	Power (kW)	Connections		Dimensions (mm)				Weight (kg)
		Outlet	Inlet	A	B	C	D	
JP 5	0.48	1" M	1" M	364	206	411	240	8.5
JP 6	0.92	1" M	1" M	401	206	411	240	10.0



The Grundfos JPRain is a compact booster pump designed for domestic and garden use. The booster unit consists of a Grundfos JPRain self-priming, composite, single-stage jet-pump, with PM1 pressure manager. The pressure manager allows the pump to start and stop automatically according to demand and protects the pump from dry running. The JPRain is also available with a pressure tank and switch or bare pump with no controller.



Features

Self-priming

With a suction-lift up to 7 metres, this pump is ideal for transferring water from wells or ground tanks. This feature makes this pump ideal for a large variety of installations.

Robust design

The materials of the pump are lightweight and ensure excellent corrosion resistance.

Protective features

The Booster version incorporates functions to protect both the pump and installation. These protective functions are dry running protection and cycling alarm.

Stable operation

The pump ensures stable operation with excellent suction capacity even when there are air bubbles and small sandy impurities in the water.

User friendly interface

The booster versions includes a user-friendly interface with LED indicators which shows, power on, pump running and alarm indication.

Applications

- Domestic rainwater



Performance

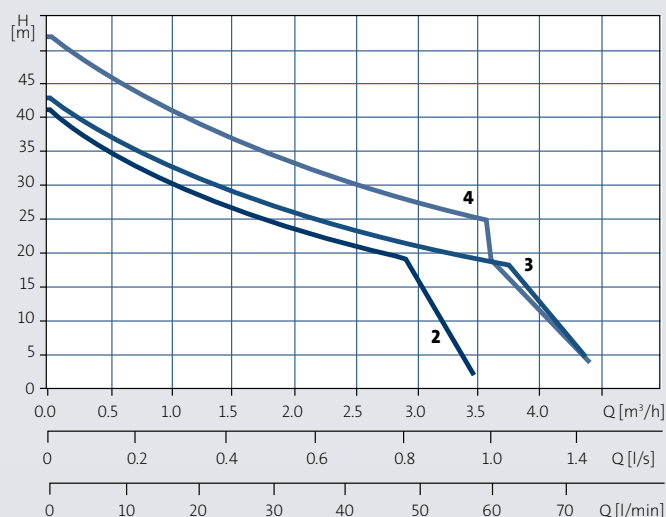

Operating Conditions

System pressure

Max. 6 bar

Suction lift

Max: 8 metres, including suction pipe pressure loss at a liquid temperature of 20 °C

Liquid temperature

0 °C to 35 °C

Ambient temperature

Max. 40 °C

Relative air humidity

Max. 95 %

Dimensions

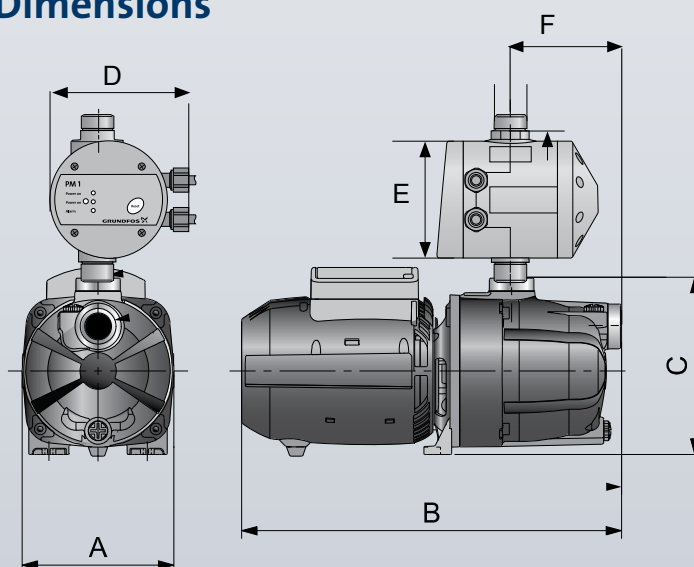

Technical Data

Mains voltage

1 x 240 V, 50 Hz

Enclosure class

IP65

Insulation class

F

Sound pressure level

JP Rain2: 83 dB

JP Rain3: 85 dB

JP Rain4: 88 dB

Start/stop frequency

Max. 20 per hour

Approvals and markings

C-tick, CE, GOST

Model	Power (kW)	Connections		Dimensions (mm)						Weight (kg)
		Outlet	Inlet	A	B	C	D	E	F	
JPRain 2	0.44	1" M	1" F	170	406	360	143	120	122	8.0
JPRain 3	0.60	1" M	1" F	170	406	360	143	120	122	8.5
JPRain 4	0.75	1" M	1" F	230	425	365	143	120	122	10.5

JP Basic

The Grundfos JP Basic is a self-priming, single-stage jet-pump. It is ideal for a wide variety of domestic water transfer and supply applications, especially where self-priming operation is necessary. The body of the JP Basic is made of cast iron treated against corrosion. Installation of the JP Basic is simply plug-and-pump, as the pump requires no motor protection.



Features

Self-priming

With a suction-lift up to 7 metres, this pump is ideal for transferring water from wells or ground tanks. This feature makes this pump ideal for a large variety of installations.

Motor protection

The single-phase JP Basic is effectively protected against any accidental overload, by built-in thermal and current protection. This means that no additional motor protection is required.

Robust design

The materials of the pump ensure excellent corrosion resistance.

Stable operation

The pump ensures stable operations with excellent suction capacity even when there are air bubbles and small sandy impurities in the water.

Applications

- Above and below ground water sources with a suction lift of up to 7 metres.



Performance

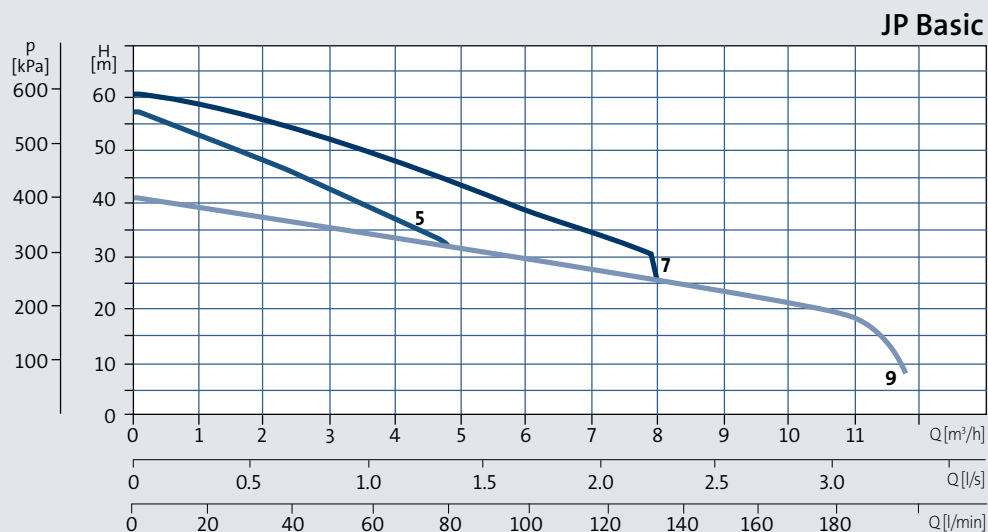

Operating Conditions

System pressure

Max. 7.5 bar (JPBasic 5, -7, -9, -11)

Suction lift

Max. 8 m, including suction pipe pressure loss at a liquid temperature of 20 °C

Liquid temperature

0 °C to 35 °C

Ambient temperature

Max. 40 °C

Relative air humidity

Max. 95 %

Technical Data

Mains voltage

1 x 240 V, 50 Hz

Enclosure class

IP44

Insulation class

F

Sound pressure level

JPBasic 5: 83 dB JPBasic 7: 85 dB JPBasic 9: 88 dB

Start/stop frequency

Max. 20 per hour

Approvals and markings

CE, C-tick, GOST

Dimensions

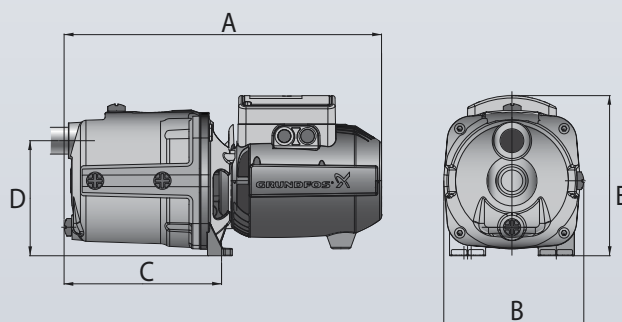

Model	Power (kW)	Connections		Dimensions (mm)					Weight (kg)
		Outlet	Inlet	A	B	C	D	E	
JP Basic 5	1.10	1" F	1¼" F	558	210	367	158	255	31
JP Basic 7	1.85	1" F	1¼" F	632	210	282	158	255	35
JP Basic 9	1.50	1¼" F	1½" F	521	214	282	175	227	27

Pressure Manager



The all-in-one Grundfos Pressure Manager is an intelligent waterworks that controls your pump in accordance with consumption in domestic water supply and booster systems. The Pressure Manager is suitable for toilets, washing machines and outside taps. This state-of-the-art product offers benefits from innovative Grundfos features including functionality, system integration, plug-and-pump convenience and ease of use. The Pressure Manager offers a choice of two excellent models: the PM1 for basic flexibility, and the PM2 for all-round control.



Features

Internal pressure tank

The Pressure Manager incorporates a small internal pressure tank which minimises the number of starts and stops of the pump in case of minor leakages.

Free position installation

The Pressure Manager can freely be installed vertically, horizontally or at an angle, if you struggle with confined spaces. Furthermore the display can be turned 360 degrees, so it is always readable.

Integrated non-return valve

Non-return valve for backflow prevention.

PM 1 - Basic flexibility

The PM1 is suitable for applications where there is a need to start and stop the pump according to consumption. It is the basic flexibility solution, offering pump start at 1.5 or 2.2 bar. The PM1 will start the pump when the starting pressure is reached it will keep running as long as there is flow. It provides dry-running protection and a cycling alarm for increased safety. In addition, it is suitable for use on generators.

PM 2 - All-round control

The PM2 is the all-round control solution, offering adjustable pump start at 1.5 to 5 bar. This enables customisation to different types of installation and desired comfort levels. The start pressure is set inside the unit, whereas current pressure is read on the intuitive LED display on the front of the Pressure Manager. The PM2 starts the pump when the starting pressure is reached and keeps running as long as there is flow. It is equipped with an internal pressure tank to minimise starts and stops in the event of leakage in the installation. In addition, the PM2 can be optimised for operation with a large

external pressure tank by enabling the 1-bar differential pressure function.

This significantly reduces the number of operating hours of the pump in installations with a pressure tank.

The PM2 is also suitable for use on generators.



Pressure Loss

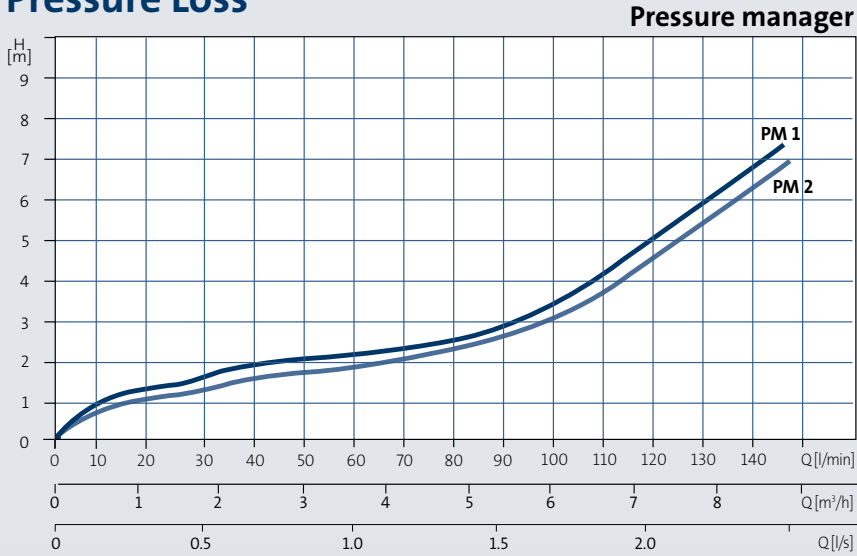

Operating Conditions

Max. operating pressure

10 bar

Minimum flow

1.0 L/min

Liquid temperature

Max 60 °C

Ambient temperature

Max. 45 °C

Maximum humidity

95 % RH

Dimensions

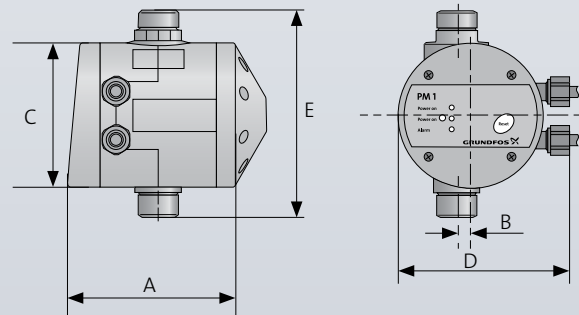

Technical Data

Mains voltage

1 x 240 VAC, 50 Hz

Enclosure class

IP65

Sound pressure level

at 0-4 m³/h 26 dB

Volume of internal pressure tank

0.1 L

Approvals and markings

VDE, CB, C-tick, CE, GOST, RoHS, WRAS, ACS

Model	Max Current (A)	Connections		Dimensions (mm)					Q/min (Lpm)	P Start (kPa)
		Outlet	Inlet	A	B	C	D	E		
PM 1-15	6	1" M	1" M	165	12	120	143	171	1 Lpm	150
PM 1-22	6	1" M	1" M	165	12	120	143	171	1 Lpm	220
PM2	10	1" M	1" M	175	12	120	143	171	1 Lpm	150-500

PM Rain



The PM Rain is a rain water harvesting device based on the pressure manager and is used in conjunction with a Grundfos pump. It ensures that all collected rainwater is used as first priority instead of precious drinking water, on applications such as toilets, laundry and watering the garden. It automatically starts the pump when it senses a demand and will switch over to mains water when your rainwater tank is empty or in the case of an electrical failure. Installation of the PM Rain is easy, simply connect it to your pipework. No level sensor is needed for the rainwater tank.



Features

Easy installation

The PM Rain incorporates a specially designed valve, which eliminates the need for a level sensor in the rainwater tank. This reduces installation time and cost.

Certified for drinking water

The PM Rain is WaterMark approved, and suitable for direct plumbing with main water.

User-friendly display

The PM Rain features a user-friendly display with LED indicators showing pump on, warning and indication of whether water is drawn from the rainwater tank or mains water supply.

Protective functions

The PM Rain incorporates functions which protect both the pump and the installation. These protective functions are dry-running protection, cycling alarm.

Backflow prevention

PM Rain features dual non-return valve for the mains water supply. This ensures that there will be no backflow into the mains supply eliminating the risk of contamination.

Applications

- Rainwater harvesting with mains water back up

Operating Conditions

System pressure

Max. 10 bar

Liquid temperature

0 °C to 60 °C

Ambient temperature

0 °C to 55 °C

Technical Data

Mains voltage

1 x 240 V, 50 Hz

Enclosure class

IP65

Pstart

2.5 to 6 bar

Pstop

Pstart+1 bar

Insulation class

B

Sound pressure level

55 dB

Approvals and markings

C-Tick, Watermark AS4020



Dimensions

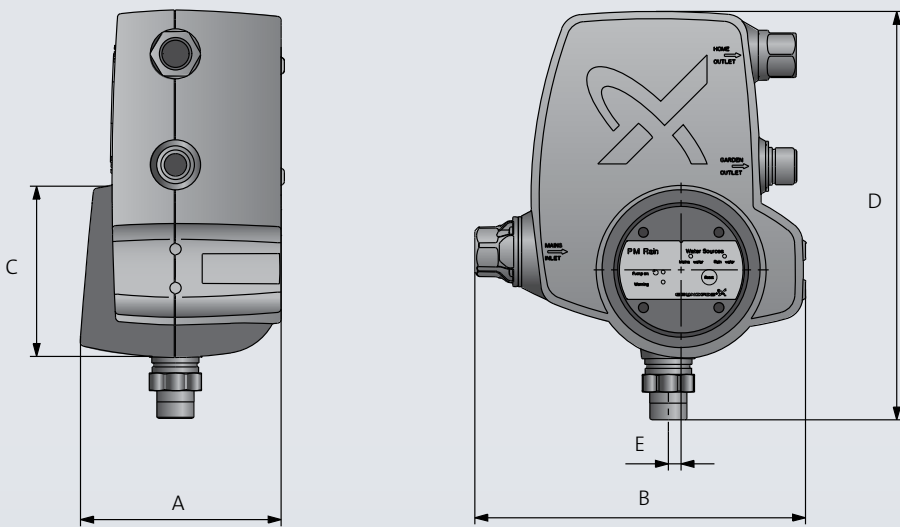

Model	Connections			Dimensions (mm)				
	Outlet (House)	Outlet (Garden)	Inlet	A	B	C	D	E
PMRain controller	¾" F	1" M	1" M	180	297	153	368	11



Pressure Tanks



The GT pressure tanks for cold-water applications are longlife tanks for both domestic and industrial applications. The GT tank ensures controlled pressure in your water supply. The result of this is better comfort in your installation by limiting the start/stop frequency of your pump, compensation for pressure drops and eliminating water hammer in pipework. GT tanks can be integrated in many different installations with a wide variety of pumps. Grundfos offers a large range of tank types and sizes, ensuring the best possible tank for your installation.



Features

Wide range of GT tanks

The GT tanks are available in sizes from 8 to 5,000 litres, suitable for vertical installation. GT tanks in sizes 24 to 80 litres are also suitable for horizontal installation.

Approved for drinking water

The Grundfos GT tanks are approved for use with drinking water.

Reducing start/stop frequency

The GT tanks ensure controlled pressure in the water supply and thereby limit the switching frequency of the pump in case of low water consumption or leakage loss.

Optimise comfort

The GT tanks increases system comfort by compensating for pressure drops when a tap is opened and reduces problems with water hammer in the pipework.

Applications

- Boost of city mains, break tank or boost from well > 8 metres



Performance

Model	Connection Size	Dimensions (mm)		Capacity (L)	Mounting type	Max pressure (kPa)
		Height	Diameter			
GT-H-2 PN10 G1 V	1" M	183	127	2	Pipe	1000
GT-H-8 PN10 G1 V	1" M	311	203	8	Pipe	1000
GT-H-18 PN10 G1 V	1" M	366	279	18	Pipe	1000
GT-H-18 PN16 G1 V	1" M	366	279	18	Pipe	1600
GT-H-60 PN10 G1 V	1" F	528	388	60	Free standing	1000
GT-H-80 PN10 G1 V	1" F	626	388	80	Free standing	1000
GT-H-80 PN16 G1 V	1" F	787	388	80	Free standing	1600
GT-H-100 PN10 G1 V	1" F	804	430	100	Free standing	1000
GT-D-130 PN10 G1 V	1¼" F	1101	406	130	Free standing	1000
GT-D-200 PN10 G1 1/4 V	1¼" F	1042	534	200	Free standing	1000
GT-U-200 PN16 G11 1/4 V	1¼" F	9967	634	200	Free standing	1600
GT-D-240 PN10 G1 1/4 V	1¼" F	1219	533	240	Free standing	1000
GT-D-300 PN10 G1 1/4 V	1¼" F	1575	533	300	Free standing	1000
GT-D-450 PN10 G1 1/4 V	1¼" F	1505	660	450	Free standing	1000

Tank Range

GT-H

GT-H is a steel pressure tank with a non-toxic butyl rubber diaphragm with a precision-moulded polypropylene liner for superior air and water separation.

GT-D

GT-D is a steel pressure tank with double diaphragm. The diaphragm is a chlorine-resistant 100% butyl diaphragm with a precision-moulded copolymer polypropylene liner for superior air and water separation.

Operating Conditions

Max. operating pressure

Max. 10/16 bar

Liquid temperature

Max. 90 °C

Technical Data

Approvals and markings

CE, GOST, NSF, WRAS, ACS

Tank pre charge recommended 10% below cut in pressure for PT systems; 70% of maximum pump pressure on PM1 and PM2 units and 70% of set point on variable speed pumps





The Grundfos SB pump is a submersible booster pump designed for the pumping of clean water for domestic and rainwater applications. The SB submersible pump is silent when submerged and therefore a noiseless alternative to surface mounted pumps. The SB pump is built of high quality composite and stainless steel materials that are resistant to corrosion. The SB is ideal for operation in a well or ground tanks, as it easily prevents solid particles from entering the pump. Furthermore, the pump features a flow switch which ensures the user a convenient experience with automatic start/stop operation and dry running protection of the pump.



Features

Noiseless operation

The SB pump emits no noise when submerged and is therefore a noiseless alternative to non-submersible pumps.

Robust design

The SB pump is built of composite and stainless steel materials which are resistant to corrosion.

Thermal overload protection

The single-phase model is effectively protected against any accidental overload, by built in thermal protection.

Dry running protection

The SB pump is protected from dry running, by means of the function of the flow switch.

Automatic operation

The flow switch for the SB pump ensures automatic operation by means of the water level in tank.

Applications

- Boost from well < 8 metres and domestic rainwater



Performance

SB

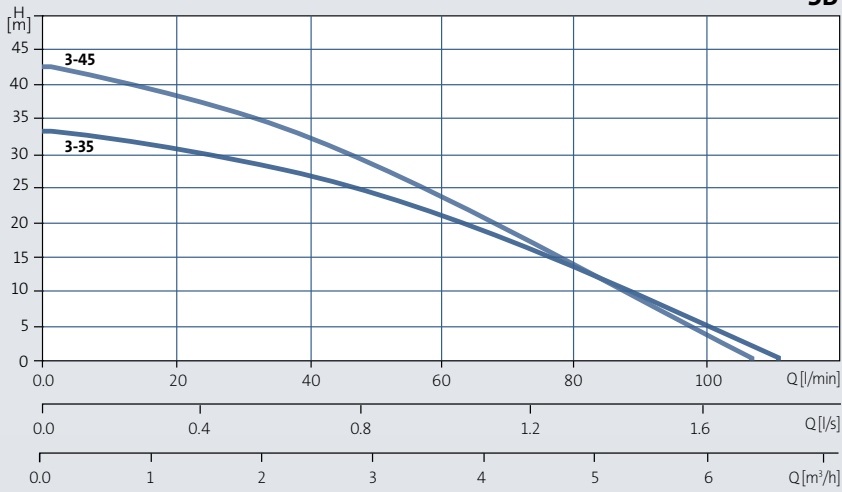

Operating Conditions

Maximum particle size

1 mm

Ambient temperature

Max 50 °C

Liquid temperature

0 to 40 °C

pH-value range

4-9

Technical Data

Mains voltage

1 x 240 V, 50 Hz

Insulation class

B

Enclosure class

IP68

Max installation depth

10 m

Approvals and markings

EAC, CSA, C-tick

Dimensions

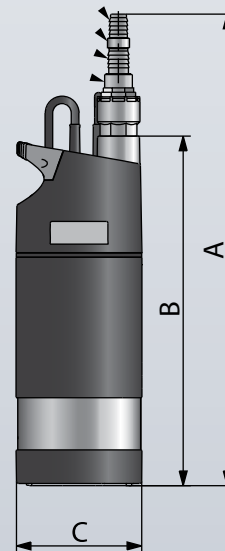

Model	Cable (m)	Power (kW)	Connection size	Dimensions (mm)			Weight (kg)
				A	B	C	
SB 3-35	15	0.8	1" F	536	390	150	9.4
SB 3-45	15	1.05	1" F	584	415	150	9.7



The Grundfos SBA pump is a submersible booster pump designed for the pumping of clean water for domestic and rainwater applications. The SBA submersible pump is silent when submerged and therefore a noiseless alternative to surface mounted pumps. The SBA pump is built of high quality composite and stainless steel materials that are resistant to corrosion. The SBA is ideal for operation in a well or ground tanks. Furthermore, the pump features a flow switch which ensures the user a convenient experience with automatic start/stop operation and dry running protection of the pump. The SBA includes an integral control unit, eliminating the need for an external pump controller. With SBA it is literally a matter of plug-and-pump.



Features

Noiseless operation

The SBA pump emits no noise when submerged and is therefore a noiseless alternative to non-submersible pumps.

Robust design

The SBA pump is built of composite and stainless steel materials which are resistant to corrosion.

Integrated protection

SBA features integrated float switch for dry-running protection.

Automatic restart

SBA with float switch automatically restarts when water is added.

Overheat protection

Built-in thermal protection immediately stops the pump if it overheats. Having cooled down, the pump automatically restarts when it reaches a normal temperature.

Longer life

A Grundfos float switch prevents air from entering the system as a result of dry running.

Applications

- Above or below ground tank



Performance

SBA

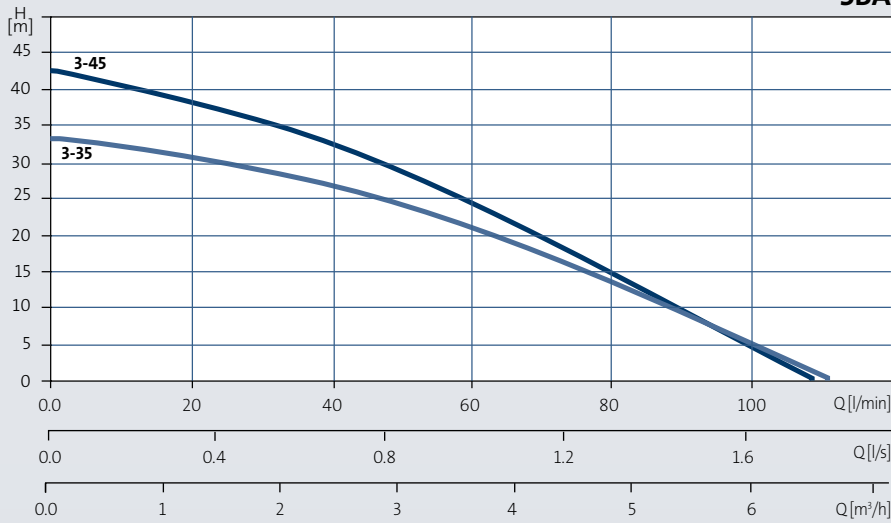

Operating Conditions

Maximum particle size

1 mm

Ambient temperature

Max 50 °C

Liquid temperature

0 to 40 °C

pH-value range

4-9

Technical Data

Mains voltage

1 x 240 V, 50 Hz

Insulation class

B

Enclosure class

IP68

Max installation depth

10 m

Approvals and markings

EAC, CSA, C-tick, CE

Dimensions

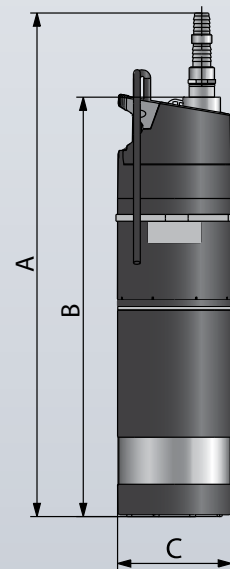

Model	Cable (m)	Power (kW)	Connection size	Dimensions			Weight (kg)
				A	B	C	
SBA 3-35	15	0.8	1" F	621	528	150	10.9
SBA 3-45	15	1.05	1" F	646	553	150	11.1

SQN (E)

SQN (E) is a small and compact submersible multi-stage pump designed for constant pressure operation in domestic applications. The motor of the SQN (E) pump is a permanent magnet motor with a micro frequency converter ensuring optimum efficiency. The built-in frequency converter features protective functions and soft-starting, which reduces starting current and gives smooth and steady acceleration and dry running protection. The SQN (E) pump is handy and user-friendly due to its low weight and 3-inch diameter. For constant pressure operation, the SQE coupled the CU300 or CU301 control unit is required



Features

Constant pressure operation

Using a CU300/301 with the SQNE your water pressure will always remain constant pressure regardless of how many family members are consuming water. As more taps are opened, the pump automatically increases its speed, maintaining your chosen pressure at any flow rate. Greater comfort is added to your life and greater value added to your home.

Excellent starting capabilities

The soft starter minimises the risk of wear on the pump and prevents overloading of the mains during start-up. Its soft-start system also reduces water hammering, light flickering and other electrical disturbances.

Overvoltage and undervoltage protection

The integrated protection prevents damage to the motor in case the supply voltage moves outside the permissible voltage range.

Overload protection

The SQN(E) eliminates the need for motor protection. If the pump is exposed to heavy load the motor will automatically reduce its speed, or if the pump is blocked it automatically stops pumping.

Over-heating protection

As an extra protection, the electronic unit has a built-in temperature sensor. When the temperature exceeds a critical limit, the pump is stopped and when the temperature has dropped, the pump automatically starts.

Protection against upthrust

The SQN (E) is fitted with an upthrust bearing protecting both pump and motor against upthrust, thus preventing breakdown during the critical start-up phase.

Operating Conditions

pH values

5 to 8

Liquid temperature

0 °C to 35 °C

Technical Data

Mains voltage

1 x 240 V, 50 Hz

Enclosure class

IP68

Insulation class

F

Installation depth

Max. 150 m below static water level

Pump diameter

74 mm

Borehole diameter

Min. 76 mm

Approvals and markings

CE, UL, cUL

Performance

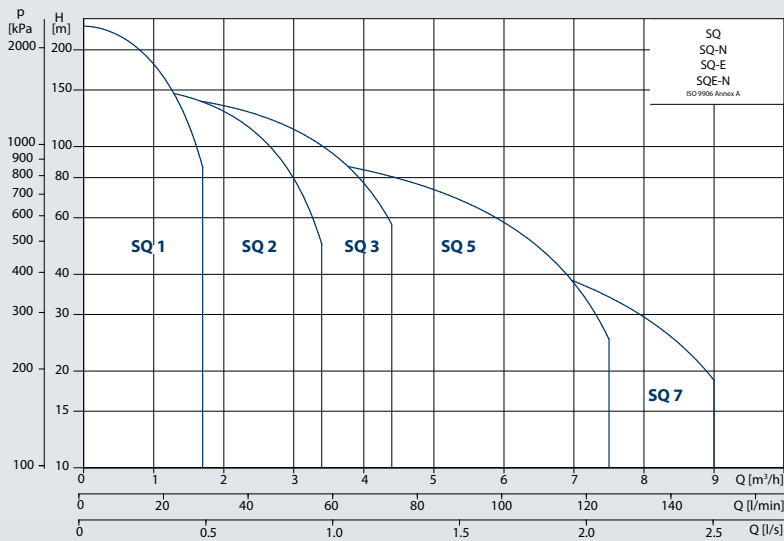

Dimensions

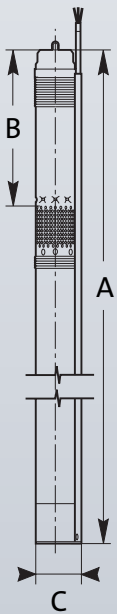

Technical Data

Model	Power-P2 (kW)	Max Current (A)	Outlet	Dimensions (mm)			Weight (kg)
				A	B	C	
SQN/SQNE 1-80	1.15	8.4	1¼" F	825	346	74	5.6
SQN/SQNE 2-55	0.7	5.2	1¼" F	741	265	74	5.8
SQN/SQNE2-70	1.15	8.4	1¼" F	768	292	74	6.4
SQN/SQNE 2-85	1.15	8.4	1¼" F	825	346	74	6.5
SQN/SQNE 3-40	0.7	5.2	1¼" F	741	265	74	5.8
SQN/SQNE 3-55	1.15	8.4	1¼" F	768	292	74	6.4
SQN/SQNE 3-65	1.15	8.4	1¼" F	825	346	74	6.8
SQN/SQNE 3-105	1.85	12	1¼" F	942	427	74	7.4
SQN/SQNE 5-50	1.68	11.2	1½" F	824	346	74	6.1
SQN/SQNE 5-70	1.85	12	1½" F	941	427	74	6.4
SQN/SQNE 7-40	1.68	11.2	1½" F	860	346	74	7.1
SQN/SQNE 7-55	1.8	12	1½" F	860	346	74	8

Model	Discharge pressure (kPa/psi)	Pumping water level (m)							
		9	12	15	18	21	24	27	30
		Output (L/min)							
SQN/SQNE 1-80	300/43	28	27	26	25	24	23	22	21
SQN/SQNE 2-55	300/43	44	41	39	37	34	30	27	-
SQN/SQNE2-70	300/43	49	47	46	45	43	41	40	38
SQN/SQNE 2-85	300/43	53	51	50	49	48	47	46	44
SQN/SQNE 3-40	300/43	48	43	36	-	-	-	-	-
SQN/SQNE 3-55	300/43	60	58	56	53	50	46	43	39
SQN/SQNE 3-65	300/43	67	65	63	61	60	57	55	53
SQN/SQNE 3-105	300/43	-	-	73	71	70	69	68	67
SQN/SQNE 5-50	300/43	95	91	86	80	75	67	63	50
SQN/SQNE 5-70	300/43	111	109	106	103	100	98	95	91
SQN/SQNE 7-40	300/43	111	103	93	83	70	-	-	-
SQN/SQNE 7-55	300/43	132	125	118	111	104	96	86	75

The Grundfos SP A is a 4-inch multi-stage, submersible pump designed for operation in boreholes. SP A is made entirely of corrosion-resistant stainless steel, offering high operating reliability regardless of the application. The SP A offers high efficiency along with great resistance to sand and other abrasive particles.



Features

100% high-grade stainless steel inside and outside

As standard, all Grundfos SP A pumps are made entirely of stainless steel DIN 1.4301 (AISI 304). Where particularly aggressive liquids are encountered, the SP pumps are available in extra high grade stainless steel DIN 1.4401 (AISI 316), or, for severe conditions, DIN 1.4539 (AISI 904 L) providing maximum reliability.

Bearings with sand channels

All bearings are water-lubricated and have a squared shape, enabling sand particles, if any, to leave the pump together with the pumped liquid.

Inlet strainer

The pump is mounted with an inlet strainer preventing particles over a certain size from entering the pump.

Non-return valve

SP A pumps have a built-in non-return valve preventing backflow in connection with pump stoppage.

Motor burnout protection

Protecting the motor against high motor temperatures is the simplest and cheapest way of avoiding a reduced motor life. The SP A motor is available with built-in temperature sensor and when used with the MP204 will monitor and protect against overheating.

Optional monitoring and controlling

A complete monitoring and control system is available for constant optimisation of the pumping system.

Operating Conditions

Liquid temperature

0 °C to 30 °C at 0.15 m/s

Higher flow past motor equals higher permissible liquid temperature. Consult Grundfos for further information.

Technical Data

Mains voltage

1 x 240 V, 50 Hz
3 x 415 V, 50Hz

Enclosure class

IP68

Insulation class

F

Installation depth

Max. 600 m

Approvals and markings

UL, CSA, VDE, CE

Performance

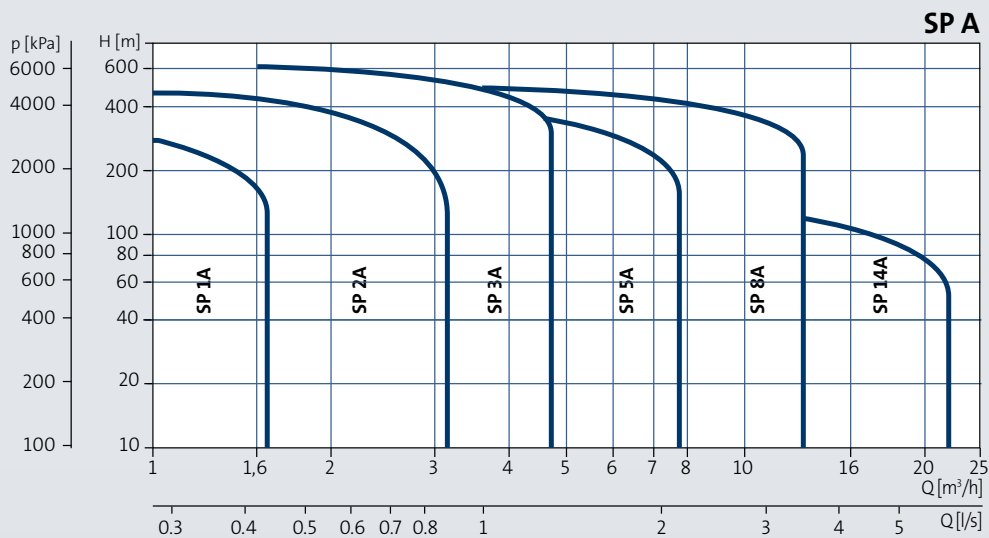

UNILIFT CC

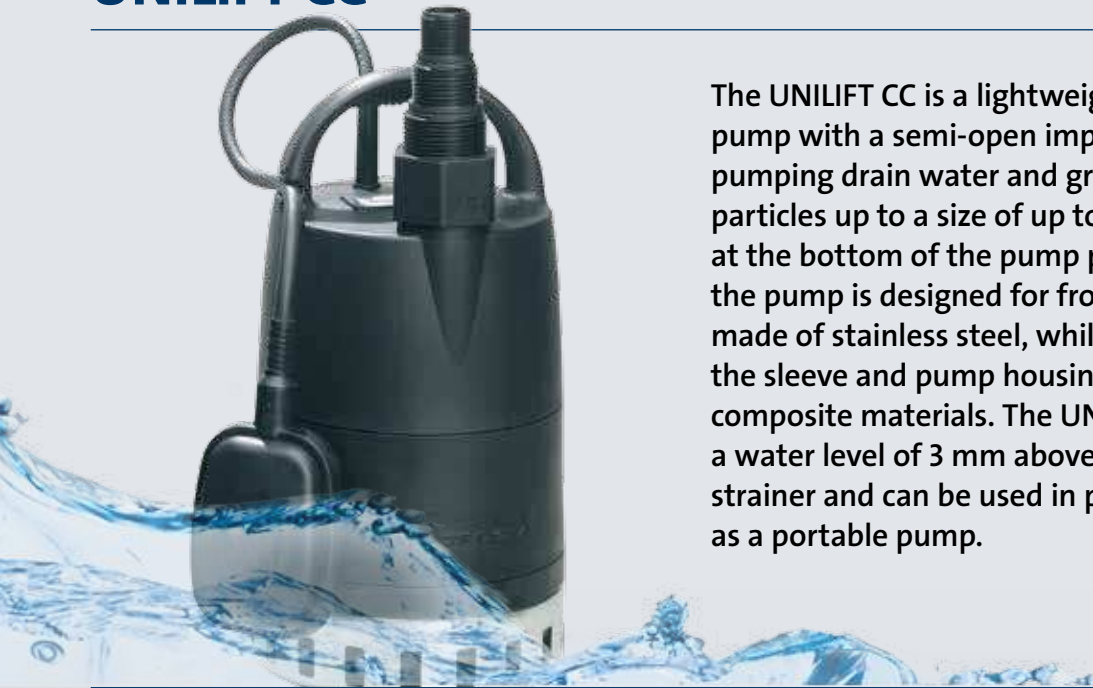

The UNILIFT CC is a lightweight single-stage drainage pump with a semi-open impeller. They are designed for pumping drain water and grey wastewater containing particles up to a size of up to 10 mm. The suction strainer at the bottom of the pump prevents particles larger than the pump is designed for from entering. The strainer is made of stainless steel, while the main pump parts, e.g. the sleeve and pump housing, are made of moulded composite materials. The UNILIFT CC can pump down to a water level of 3 mm above the floor by removing the strainer and can be used in permanent installations or as a portable pump.



Features

Prevention of backflow

The pump is supplied with an adapter and a non-return valve to prevent backflow through the pump when it stops.

Robust design

The materials of the pump ensure excellent corrosion resistance. Furthermore, the CC 7 and 9 have a built in V-ring mechanical shaft seal which offers wear resistance and a long operating life.

Thermal overload protection

The single-phase version is effectively protected against any accidental overload, by built-in thermal protection. This means that no additional motor protection is required.

Auto-restart

In case the motor cuts out due to thermal overload, the motor automatically starts again when it has cooled to normal temperature.

Handy and easily transportable

The light weight of the pump and the carry handle mounted on the housing make it handy and easily transportable.

Automatic operation

The pump has a float switch for automatic on/off operation between two liquid levels.

Self-venting valve

The UNILIFT CC 7 features a self-venting valve. Place the pump underwater, engage the power, and relax. The self-venting valve located in the handle prevents air from getting trapped in the pump.

Good connectivity

Includes multiple adapter for thread sizes from 3/4" to 1/1/4"

Applications

- Domestic wastewater



Performance

UNILIFT CC

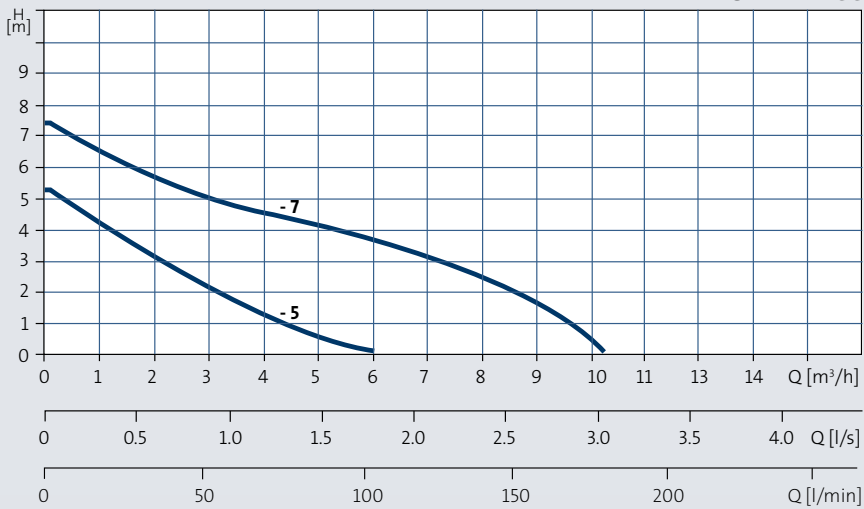

Operating Conditions

Liquid temperature

0 °C to 40 °C

Max. particle size

Ø10 mm

pH concentration

4 to 9

Max. installation depth

10 m

Technical Data

Mains voltage

1 x 240 V, 50 Hz

Enclosure class

IP68

Insulation class

B or F

Cable type

H07RN-F

Approvals and markings

VDE, CSA, GOST and LGA according to DIN EN 12050-2

Dimensions

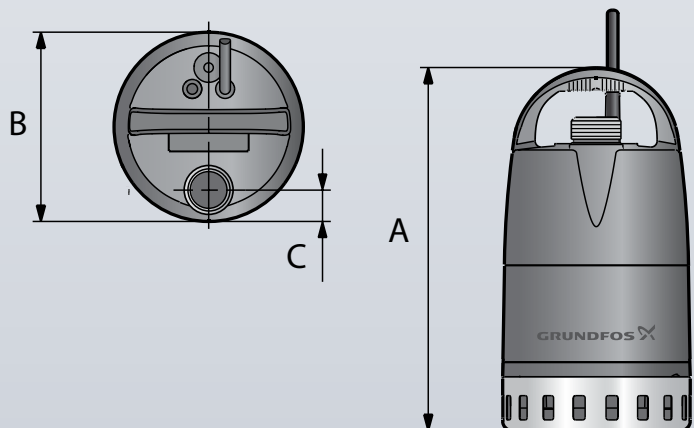

Model	Cable length (m)	Power - P2 (kW)	Connection size	Dimensions (mm)			Weight (kg)
				A	B	C	
Unilift CC 5	10	0.25	1¼" M	305	160	26.5	4.35
Unilift CC 7	10	0.38	1¼" M	305	160	26.5	4.60

UNILIFT KP



The UNILIFT KP is a lightweight, single-stage pump with a semi-open impeller. They are designed for liquid transfer and pumping of drain water and grey wastewater containing particles up to a size of Ø10. All UNILIFT KP pumps are mostly made of stainless steel, with a stainless steel sleeve for cooling during operation. The pumps are small and handy, suitable for permanent installation or as a portable pump. The suction strainer at the bottom of the pump prevents particles larger than the pump is designed for from entering. The suction strainer is clipped on to the pump housing for easy removal, in case of maintenance. All UNILIFT KP pumps can be supplied with or without float switch, for automatic or manual operation.



Features

Lightweight and robust

The KP is a lightweight pump designed specifically for drainage jobs. Its stainless steel surface makes it robust, durable and corrosion free, which reduces maintenance to an absolute minimum.

Wet runner

The pump is designed with a canned rotor, which hermetically seals the rotor from the stator. This eliminates the need for a shaft seal, making the pump highly reliable and service friendly.

Prevention of backflow

An optional non-return flap valve can be fitted in the outlet in order to prevent backflow when the pump stops operating.

Thermal overload protection

The single-phase version is effectively protected against any accidental overload, by built-in thermal protection. This means that no additional motor protection is required.

Auto-restart

In case the motor cuts out due to thermal overload, the motor automatically starts again when it has cooled to normal temperature.

Handy and easily transportable

The carry handle mounted on the pump housing makes it handy and easily transportable.

Option for automatic operation

The pumps are available with float switches for automatic on/off operation between two liquid levels or with vertical float for operation in confined areas.

Applications

- Domestic wastewater



Performance

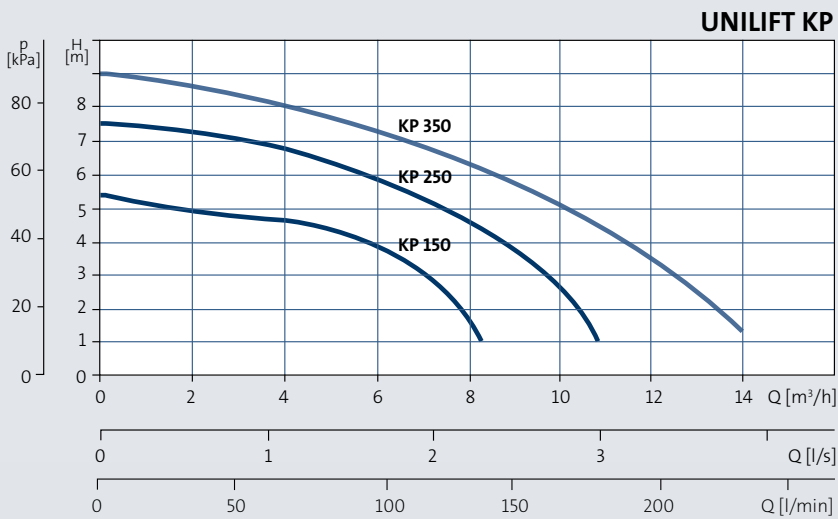

Operating Conditions

Liquid temperature
0 °C to 50 °C

Max. particle size
Ø10 mm

pH concentration
4 to 9

Max. installation depth
10 m

Technical Data

Mains voltage
1 x 240 V, 50 Hz

Enclosure class
IP68

Insulation class
F

Cable type
H07RN-F

Approvals and markings
CE, LGA, VDE, GS, EMV, GOST, UL, CSA and C-tick

Dimensions

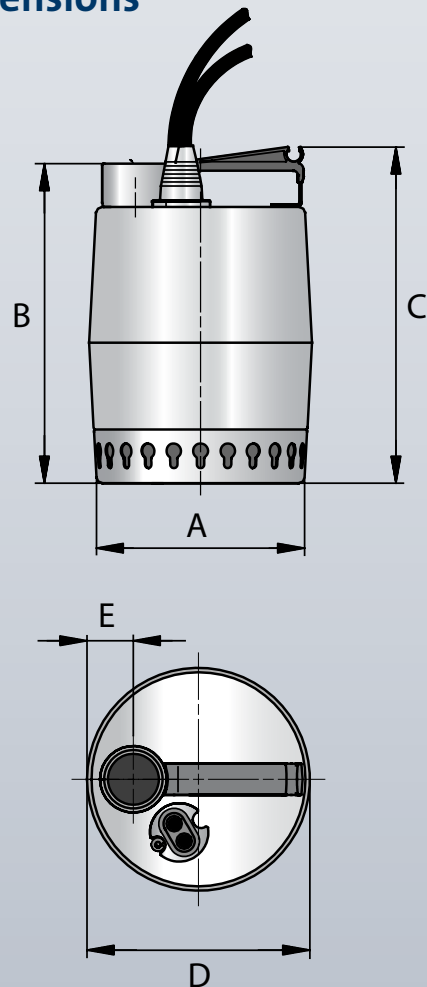

Model	Cable length (m)	Power - P2 (kW)	Connection size	Dimensions (mm)					Weight (kg)
				A	B	C	D	E	
Unilift KP 150	5	0.14	1¼" F	140	220	226	148	30	6.3
Unilift KP 250	5	0.25	1¼" F	140	220	226	148	30	6.6
Unilift KP 350	5	0.35	1¼" F	140	220	226	148	30	7.2

UNILIFT AP 12

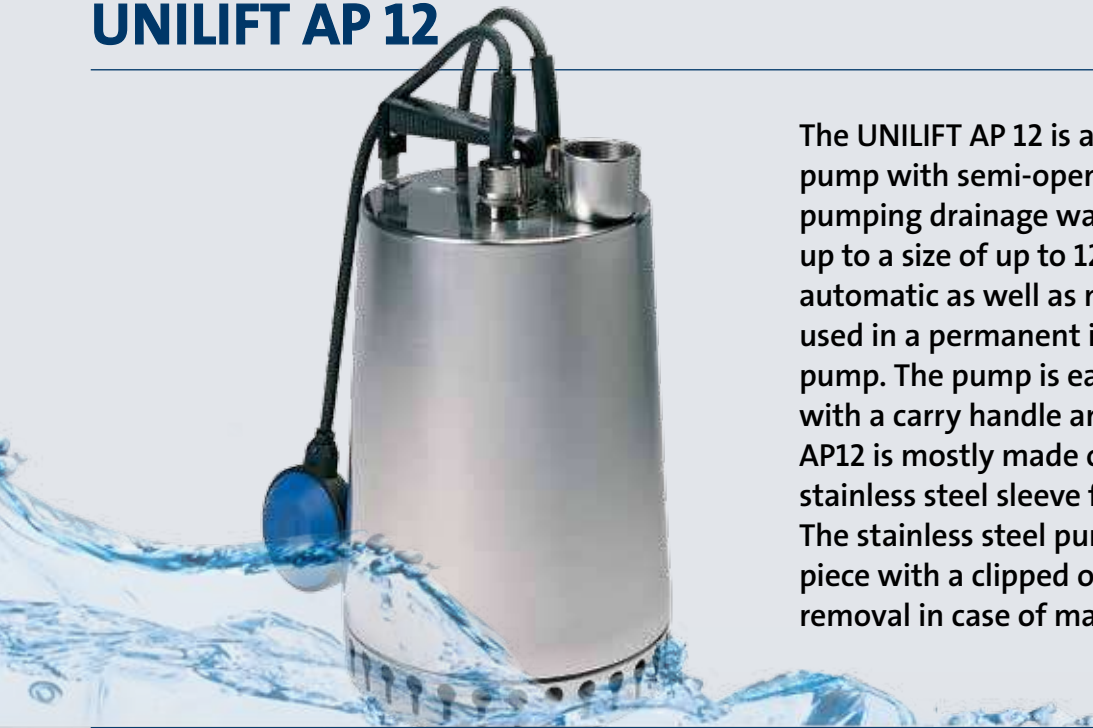

The UNILIFT AP 12 is a single-stage, submersible pump with semi-open impeller, designed for pumping drainage water containing particles up to a size of up to 12 mm. UNILIFT AP12 is for automatic as well as manual operation and can be used in a permanent installation or as a portable pump. The pump is easily installed as it's fitted with a carry handle and 10 m mains cable. UNILIFT AP12 is mostly made of stainless steel, with a stainless steel sleeve for cooling during operation. The stainless steel pump sleeve is made in one piece with a clipped on suction strainer for easy removal in case of maintenance.



Features

Robust design

The materials of the pump ensure excellent corrosion resistance. The pump housing and impeller are made of high quality stainless steel. Furthermore, the mechanical shaft seal offers high-wear resistance and a long operating life.

Thermal overload protection

The single-phase version is effectively protected against any accidental overload by built-in thermal protection. This means that no additional motor protection is required.

Handy and easily transportable

The carry handle mounted on the pump housing makes it handy and easily transportable.

Option for automatic operation

The pumps are available with float switches for automatic on/off operation.

Applications

- Domestic wastewater



Performance

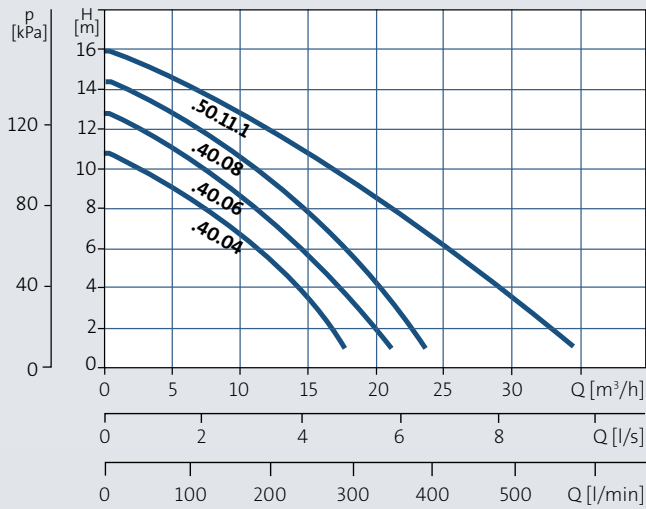

Operating Conditions

Liquid temperature
0 °C to 55 °C

Max. particle size
Ø12 mm

pH concentration
4 to 10

Max. installation depth
10 m

Technical Data

Mains voltage
1 x 240 V, 50 Hz
3 x 415 V, 50 Hz

Enclosure class
IP68

Insulation class
F

Cable type
H07RN-F

Approvals and markings
VDE, LGE, UL and CSA

Dimensions

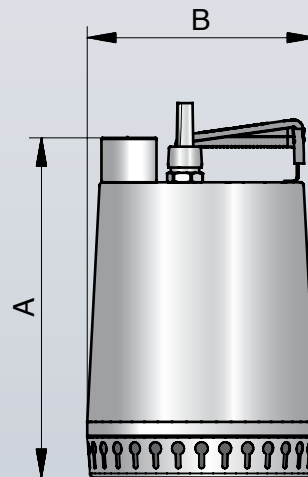

Model	Cable length (m)	Power - P2 (kW)	Connection size	Dimensions (mm)		Weight (kg)
				A	B	
Unilift AP12.40.04	10	0.4	1½" F	321	216	11
Unilift AP12.40.06	10	0.6	1½" F	321	216	11
Unilift AP12.40.08	10	0.8	1½" F	346	216	12.6
Unilift AP12.50.11	10	1.1	2" F	357	241	15.1

UNILIFT AP 35 & 50

The UNILIFT AP 35 & 50 is a single-stage, submersible pump with vortex impeller, designed for pumping effluent and sewage, containing particles up to a size of Ø50 mm (Unilift AP 50) and Ø35 mm (Unilift AP 35) depending on the pump size. UNILIFT AP 35 & 50 is available for automatic as well as manual operation and can be used in a permanent installation or as a portable pump. The pump is easily installed, as it is fitted with a carry handle and 10m mains cable. UNILIFT AP 35 & 50 is mostly made of stainless steel, with a stainless steel sleeve for cooling during operation. The stainless steel pump sleeve is made in one piece, with a clipped on suction strainer, for easy removal, in case of maintenance.



Features

Robust design

The materials of the pump ensure excellent corrosion resistance. The pump housing and impeller are made of high quality stainless steel. Furthermore, the mechanical shaft seal offers high-wear resistance and a long operating life.

Thermal overload protection

The single-phase version is effectively protected against any accidental overload, by built-in thermal protection. This means that no additional motor protection is required.

Handy and easily transportable

The carry handle mounted on the pump housing makes it handy and easily transportable.

Option for automatic operation

The pumps are available with float switches for automatic on/off operation.

Operating Conditions

Liquid temperature

0 °C to 55 °C

Max. particle size

AP 35 - Ø35 mm

AP 50 - Ø50 mm

pH concentration

4 to 10

Max. installation depth

10 m

Technical Data

Mains voltage

1 x 240 V, 50 Hz

Enclosure class

IP68

Insulation class

F

Cable type

H07RN-F

Approvals and markings

VDE, LGE, UL and CSA

Performance

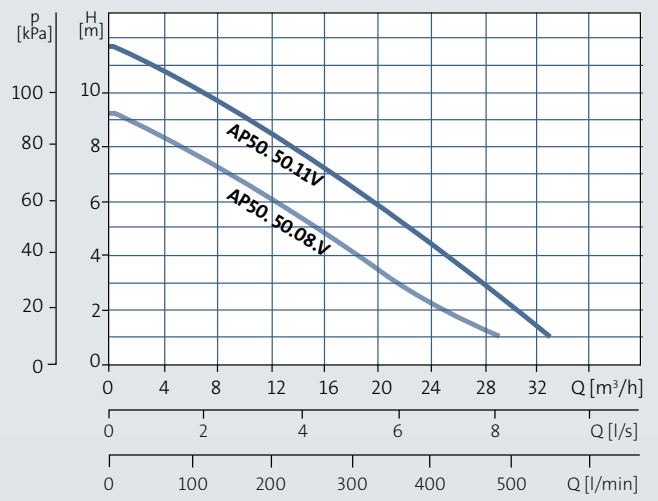
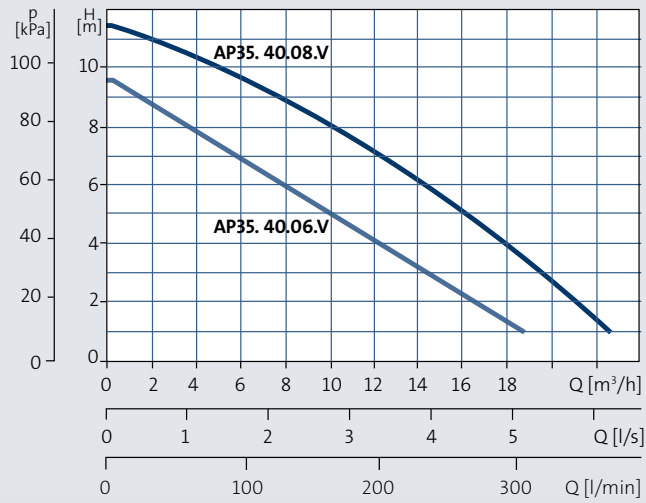

Dimensions

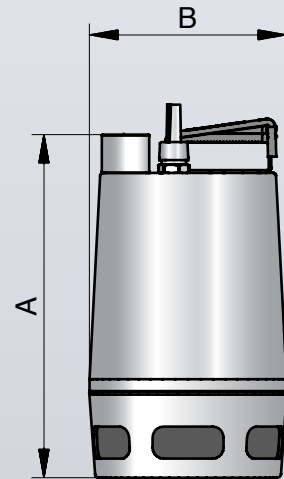

Model	Cable length (m)	Power - P2 (kW)	Connection size	Dimensions (mm)		Weight (kg)
				A	B	
Unilift AP35.40.06	10	0.6	1½" F	376	216	11.4
Unilift AP35.40.08	10	0.8	1½" F	410	216	12.7
Unilift AP50.50.08	10	0.8	2" F	436	241	15.1
Unilift AP50.50.11	10	1.1	2" F	436	241	15.1



UNILIFT AP 35B & 50B



UNILIFT AP Basic pumps are single-stage pumps with a vortex impeller. The pumps are designed for pumping dirty water, untreated wastewater containing particles up to a size of Ø50 mm, depending on the pump size. All UNILIFT AP Basic pumps are made of stainless steel with a composite baseplate. The UNILIFT AP Basic range is designed for submerged operation, either free-standing or on the base plate. In addition the pumps are suitable for installations on auto couplings, which allows easy access to the pump for maintenance and other purposes. All UNILIFT AP Basic pumps can be supplied with or without float switch, for automatic or manual operation.



Features

Robust design

The materials of the pump ensure excellent corrosion resistance. The pump housing and impeller are made of high quality stainless steel. Furthermore, the mechanical shaft seal offers high-wear resistance and a long operating life.

Thermal overload protection

The single-phase version is effectively protected against any accidental overload by built-in thermal protection. This means that no additional motor protection is required.

Option for automatic operation

The pumps are available with float switches for automatic on/off operation.

Auto coupling

UNILIFT AP Basic pumps are suitable for installation on an auto coupling at the bottom of a collecting tank with guide rails going to the top. A guide rail system is available from Grundfos as an accessory.

Operating Conditions

Liquid temperature

0 °C to 40 °C

Max. particle size

AP35 - 35 mm and AP50 - 50 mm particle size

pH concentration

4 to 10

Max. installation depth

7 m

Technical Data

Mains voltage

1 x 240 V, 50 Hz
3 x 415 V, 50 Hz

Enclosure class

IP68

Insulation class

F

Cable type

H07RN-F

Approvals and markings

VDE, LGE, UL and CSA



Performance

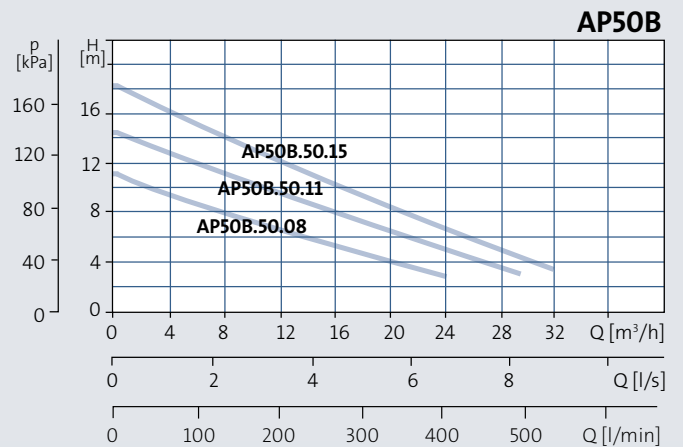
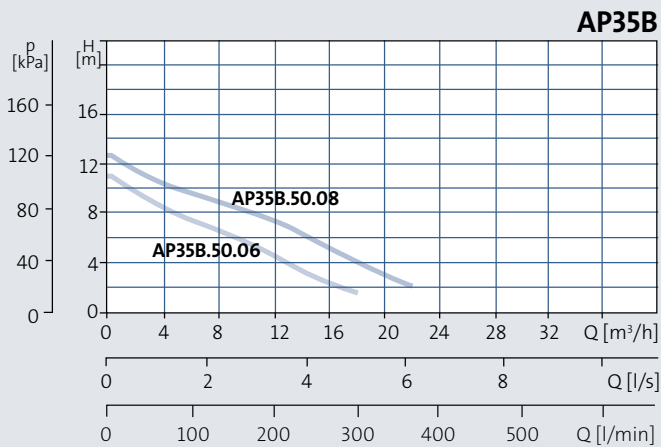

Dimensions

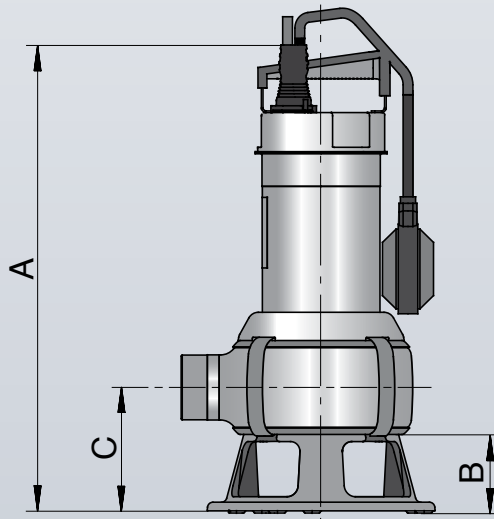

Model	Cable length (m)	Power (kW)	Connection size	Dimensions (mm)			Weight (kg)
				A	B	C	
Unilift AP35B-50.06-A1V	10	0.66	2" F	443	73	116	10.3
Unilift AP35B-50.08-A1V	10	0.71	2" F	468	73	116	11.8
Unilift AP50B.50.08.A1V	10	0.74	2" F	468	73	116	10.1
Unilift AP50B.50.11.A1V	10	1.1	2" F	468	73	116	10.2
Unilift AP50B.50.11.3V	10	1.3	2" F	468	73	116	9.7
Unilift AP50B.50.15.3V	10	1.5	2" F	468	73	116	10



SOLOLIFT 2



Sololift2 lifting stations are practical, compact and ready to install solution for discharging domestic effluent that cannot reach the main sewage pipe directly. They have the ability to grind and evacuate sewage and wastewater quickly and efficiently. They offer the ideal solution for the renovation and modernisation of existing buildings, where the location may be remote from the main soil pipe without the need for costly pipe installations. Sololift2s are able to be installed where a natural slope cannot be installed in a shower or toilet. Further, they are available in wall hung and freestanding models which cater to every space.



Features

- The most powerful, reliable and service friendly lifting station on the market
- Unique, welded, pressure tight tank
- Smart adjustable inlet connectors allow movement of up to 10 mm - easy installation and replacement
- Captive screw fastening, external pressure switch and tank draining enable fast and clean repairs and service

Technical Data

- Maximum liquid temperature: 50°C (90°C SOLOLIFT2 C-3 (30 min))
- Unique, welded, pressure tight tank to ensure safety and reliability particularly in high pressure grey water applications
- Smart adjustable inlet connectors allow movement of up to 10 mm, both vertically and horizontally for easy fitting to existing pipes
- 1.2 metre cable with plug

Applications

- SOLOLIFT2 lifting stations are practical, compact, and ready to install solution for discharging domestic effluent that cannot reach the main sewage pipe directly
- Sololift2 WC versions grind and evacuate sewage and wastewater quickly
- They are the ideal solution for the renovation or modernization of existing buildings where the location may be remote from the main soil pipe with out the need for costly pipe installations
- Enables installations of toilets and showers where a natural slope cannot be established
- The SOLOLIFT2 is ready to install offering easy installation and maintenance
- Wall hung and freestanding models cater to every space

Dimensions

Model	Power (Watts)	Dimensions (mm)		Weight (kg)
		H	L	
SOLOLIFT WC-1	620	347	453	7.2
SOLOLIFT WC-3	620	347	453	7.5
SOLOLIFT CW-3	620	368	495	7
SOLOLIFT C-3	640	255	373	6.5
SOLOLIFT D-2	280	147	147	4.2

SOLOLIFT2 C-3 for washing machines, dishwasher, kitchen sink, bathtub, shower and washbasin

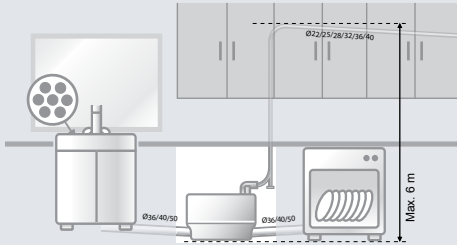

SOLOLIFT2 D-2 for shower and wash basin

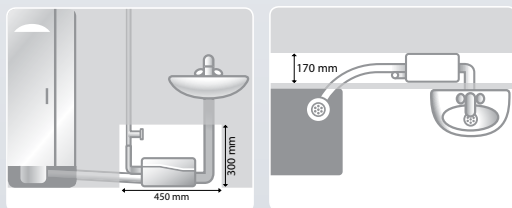

SOLOLIFT2 WC-1 for single toilet and washbasin

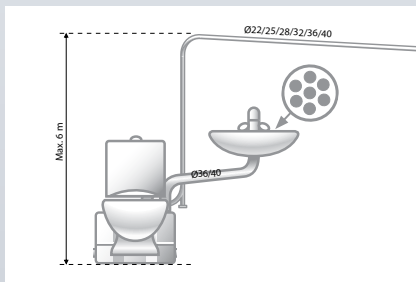

SOLOLIFT2 WC-3 for toilet, washbasin, bidet and a shower

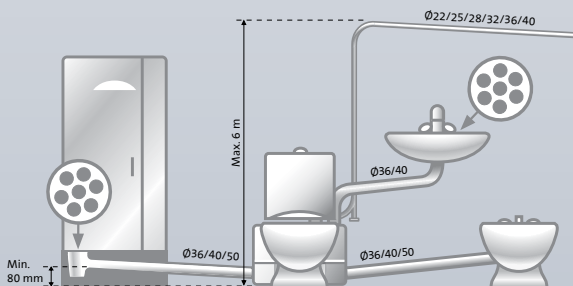

SOLOLIFT2 CWC-3 for wall-hung toilet, washbasin, bidet and a shower

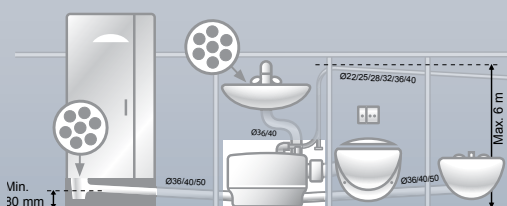

Technical Data

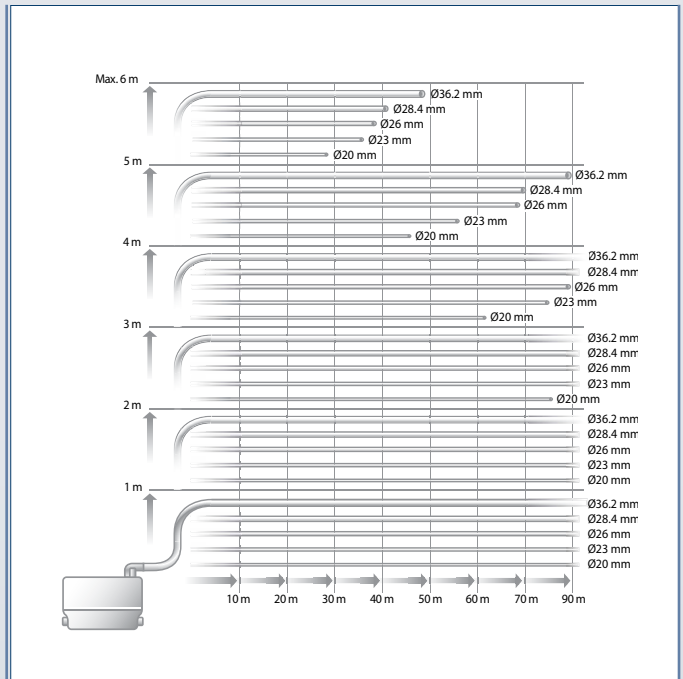

SOLOLIFT2 C-3

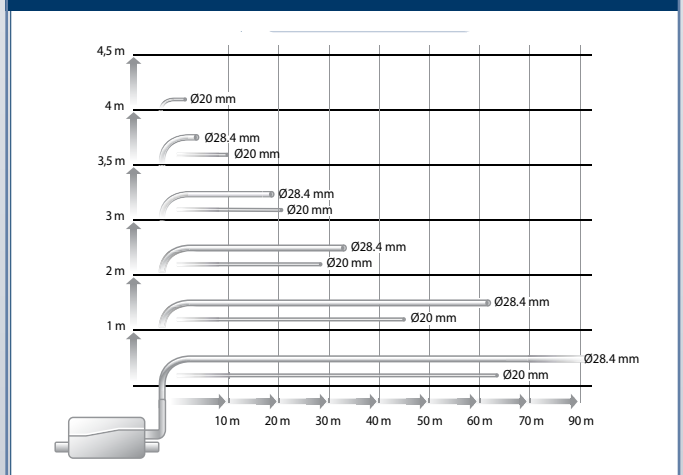

SOLOLIFT2 D-2

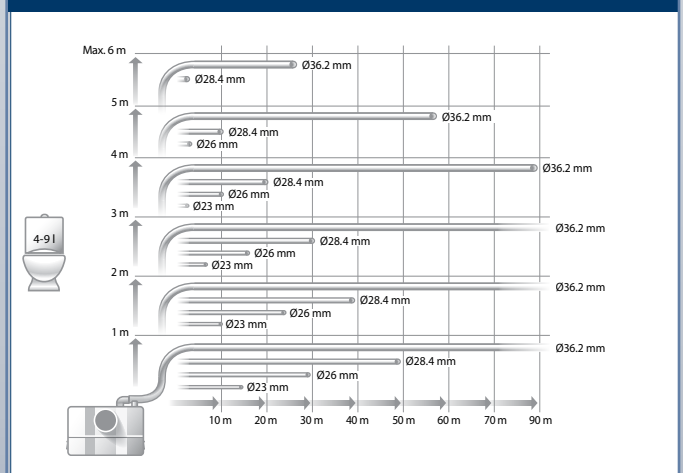

SOLOLIFT2 WC-1 SOLOLIFT2 WC-3 SOLOLIFT2 CWC-3



The UPA Homebooster is a circulator pump designed for pressure boosting hot water systems. The pump provides additional pressure to showers, taps and similar outlet points. The UPA Homebooster is for use in open systems. The pump incorporates a flow switch which starts or stops the pump when a tap is turned on or off.



Features

Increased comfort

Typically boosting 50 to 75kPa to the existing inlet pressure ensure a steady firm pressure, perfect to boost hot water pressure throughout the home.

Robust design

The pump is made of materials that ensure excellent corrosion resistance. Designed for open systems UPA is constructed from quality stainless steel with a high grade composite impeller.

Quiet operation

Whisper quiet operation makes the UPA Homebooster suitable to be unobtrusively installed in the roof space.

Automatic operation

Built in flow sensor automatically starting with water flow.

Performance

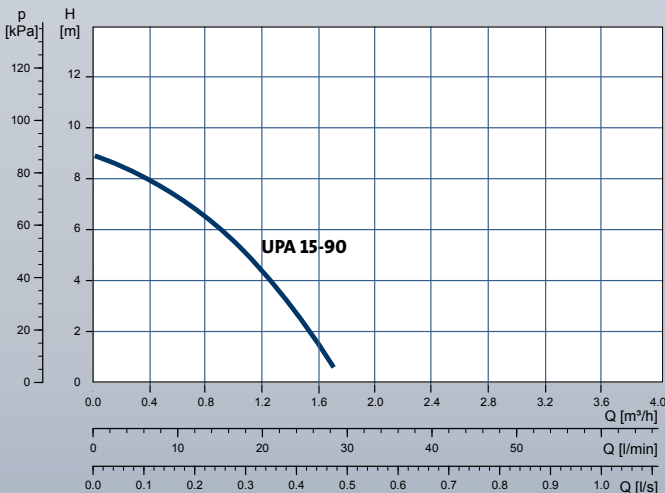

Applications

- Domestic hot water circulation

Operating Conditions

System pressure

6 bar

Liquid Temperature

2 - 95 degrees

Ambient Temperature

40 °C

Relative Air Humidity

95 %

Technical Data

Mains voltage

1 x 240 V, 50 Hz

Enclosure class

IP42

Insulation class

H



UP 15-14BA PM

The COMFORT range is designed for re-circulation of domestic hot water in one family houses. The COMFORT PM range is the high efficiency choice with an energy usage of only 8 W. The intelligent COMFORT AUTOADAPT PM automatically adapts to the individual hot water consumption pattern in the household and only runs when hot water is needed.



Features

Quiet operation

The low noise permanent magnet motor, at <43dBa the Comfort PM is ultra-quiet.

Reduce wastewater

All COMFORT pumps - with or without the autoadapt function - combined with a return pipe deliver instantly hot water all over the house. This eliminates the expensive and annoying wait for the water to get warm and reduces the annual consumption of domestic water. The results are lower costs while still ensuring the comfort of instant hot water.

Robust design

The pump is made of materials that ensure excellent corrosion resistance. Designed for open systems Comfort PM is constructed from quality brass housing with a high grade composite impeller.

AUTOADAPT

The AUTOADAPT version learns the user pattern of the customer and learns from it. It only runs when hot water is needed.

Performance

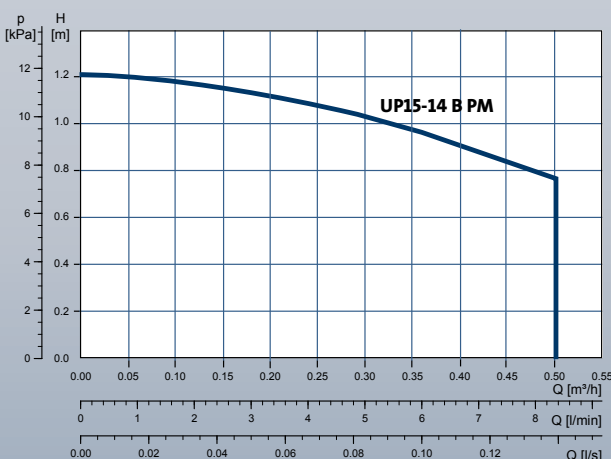

Applications

- Domestic hot water circulation

Operating Conditions

System pressure

10 bar

Liquid Temperature

2 to 110 °C

Ambient Temperature

40 °C

Relative Air Humidity

95 %

Technical Data

Mains voltage

1 x 240 V, 50 Hz

Enclosure class

IP44

Insulation class

F

Sound pressure level

43 dB

Approvals and markings

AS4020

Dimensions

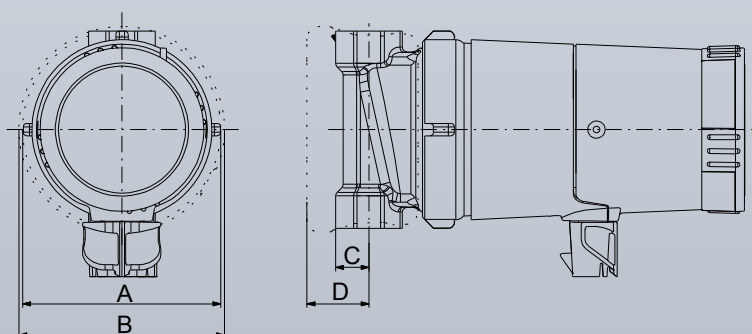

Model	Connection size	Dimensions (mm)				Weight (kg)
		A	B	C	D	
UP15-14B PM	½" F	84	13.5	133	80	1

UPS(N)



Grundfos UPS(N) pumps are the ideal choice for a wide range of domestic and commercial applications. The UPS(N) pumps are 3-speed wet rotor circulators and come in a wide range of materials and sizes. They feature an integrated pump and motor design ensuring greater ease of installation and durability. Maintenance free and whisper-quiet, these pumps are ideal for a variety of domestic and commercial heating and cooling systems.



Features

Energy efficient

A speed switch on the motor allows the pump to be adjusted to the needs of the application, improving pump efficiency and reducing energy consumption.

Robust design

The pump is made of materials that ensure excellent corrosion resistance. Designed for open systems UPS(N) is constructed from quality stainless steel with a high grade composite impeller. The UPS is constructed from rugged cast iron and is the perfect choice for closed systems.

Quiet operation

Canned motor provides an operating noise level at less than 43 decibels, the UPS is extremely quiet.

Easy installation

The UPS is a compact, inline circulator pump, making it suitable for most installations.

Operating Conditions

System pressure

10 bar

Liquid Temperature

2 to 110 °C

Ambient Temperature

40 °C

Relative Air Humidity

95 %

Technical Data

Mains voltage

1 x 240 V, 50 Hz

Enclosure class

IP44

Insulation class

F

Sound pressure level

43 dB

Approvals and markings

UPS(N) AS4020

Applications

- Circulating hot or cold water in open or closed systems.

Performance

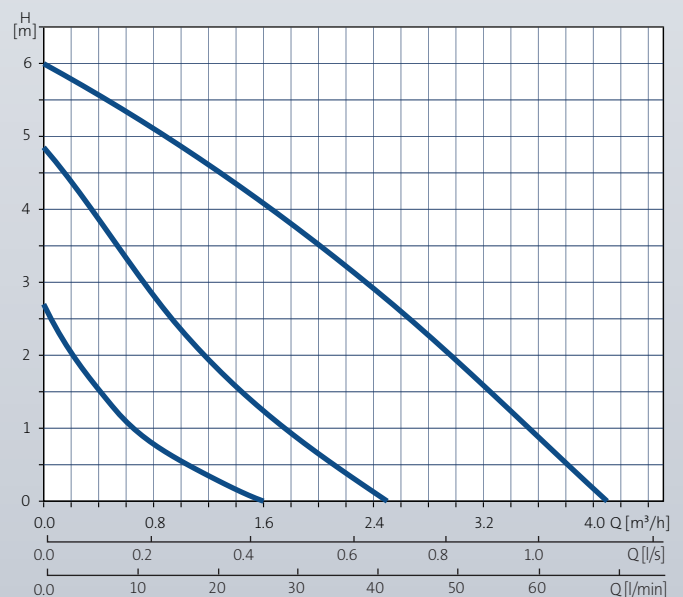

Dimensions

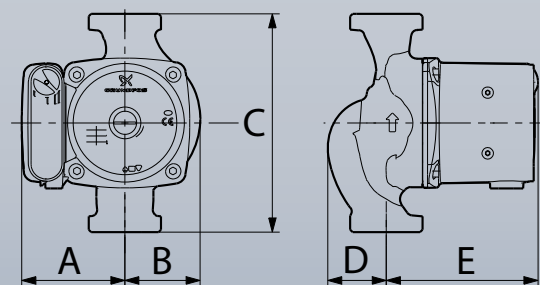

Model	Connection size	Dimensions (mm)					Weight (kg)
		A	B	C	D	E	
UPS20-60N	¾" F	75	51	150	28	102	2.8



A typical pump in a system runs at full speed day and night. The ALPHA2 (N) from Grundfos adapts to the variable demand while keeping your comfort, saving a considerable amount of electricity. The installation of a GRUNDFOS ALPHA2 (N) pump will decrease the power consumption considerably, reduce noise from radiator valves and similar fittings, and improve the control of the system. The unique Grundfos AUTOADAPT function ALPHA2 (N) will analyse and adjust automatically to your heating and water use demands. Available in in both stainless steel for hot water (open) systems and cast iron for heating (closed) systems.



Features

Robust design

The pump is made of materials that ensure excellent corrosion resistance. Designed for open systems Alpha2 N is constructed from quality stainless steel with a high grade composite impeller. The Alpha2 is constructed from rugged cast iron and is the perfect choice for closed systems.

Quiet operation

Permanent magnet motor provides an operating noise level at less than 43 decibels, the Alpha2 is whisper quiet.

AUTOADAPT

The pump learns the user pattern of the customer and learns from it. It only runs when hot water is needed.

Energy efficient

The reduction in power consumption has been achieved by using the latest permanent magnet motor technology.

Applications

- Heating systems

Performance

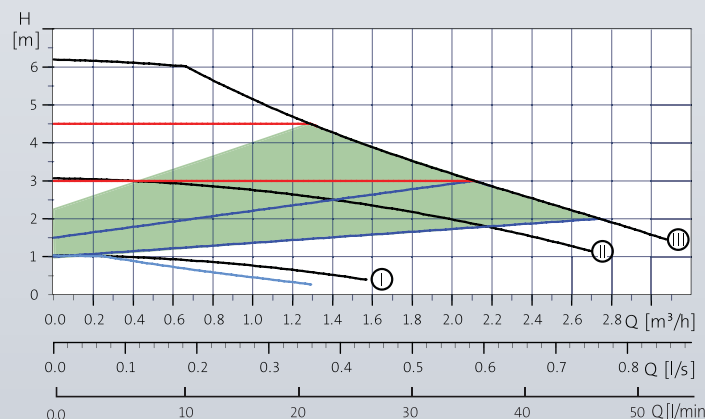

Dimensions

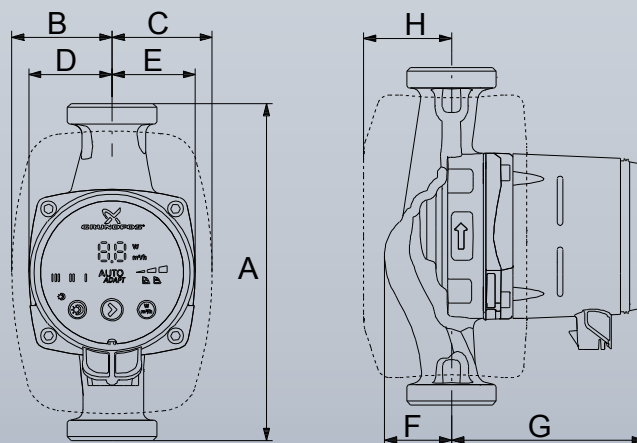

Operating Conditions

System pressure

10 bar

Liquid Temperature

2 to 110 °C

Ambient Temperature

40 °C

Relative Air Humidity

95 %

Technical Data

Mains voltage

1 x 240 V, 50 Hz

Enclosure class

IP44

Insulation class

F

Sound pressure level

43 dB

Approvals and markings

AS4020

Model	Connection size	Dimensions (mm)								Weight (kg)
		A	B	C	D	E	F	G	H	
Alpha2 (N) 25-60 130	¾" F	130	60.5	60.5	44.5	44.5	35.8	103.5	52	2.0
Alpha2 (N) 25-60 180	¾" F	180	60.5	60.5	44.5	44.5	35.8	103.5	52	2.0

Engineering Data

UNITS OF PRESSURE

		CONVERT TO →					
		Kilopascal	Metrehead	Bar	bs per sq. inch	Feet of Water	Atmosphere
CONVERT FROM ↓		Multiply By					
Kilopascal	kPa	1	0.102	.01	0.145	0.335	-
metrehead	m	9.804	1	0.098	1.42	3.28	0.098
Bar	Bar	100	10.20	1	14.5	33.45	1
lbs/sq inch	psi	6.895	.704	0.069	1	2.307	0.069
Feet of Water	ft	2.98	0.3048	0.03	0.4335	1	0.03
Atmosphere	At	100	10.33	1.0	14.7	33.9	1

NOZZLE FLOW RATES (litres/sec)

Pressure		Diameter of Nozzle (inches*) mm									
		5/64"	5/32"	1/4"	5/16"	25/64"	15/32	5/8"	25/32"	1"	
kPa	psi	2	4	6	8	10	12	16	20	25	
200	29	0.06	0.25	0.56	1.01	1.57	2.26	4.02	6.29	9.82	
300	43	0.08	0.31	0.69	1.23	1.93	2.77	4.93	7.70	12.03	
400	58	0.09	0.36	0.80	1.42	2.22	3.20	5.69	8.89	13.89	
500	73	0.10	0.40	0.89	1.59	2.48	3.58	6.36	9.94	15.53	
600	87	0.11	0.43	0.98	1.74	2.72	3.92	6.97	10.89	17.02	
700	102	0.12	0.47	1.06	1.88	2.94	4.23	7.53	11.76	18.38	
800	116	0.12	0.50	1.13	2.01	3.14	4.53	8.05	12.58	19.65	
900	131	0.13	0.53	1.20	2.13	3.33	4.80	8.54	13.34	20.84	
1000	145	0.14	0.56	1.26	2.25	3.52	5.06	9.00	14.06	21.97	

UNITS OF FLOW RATE

		CONVERT TO →				
		Imperial Gallons per min	US Gallons per min	Cubic metres per hour	Litres per second	Litres per minute
CONVERT FROM ↓		Multiply By				
Imperial Gallons per min		1	1.2	.273	.076	4.546
US Gallons per min		.833	1	.227	.063	3.787
Cubic Metres per hour		3.666	4.4	1	.278	16.66
Litres per second		13.19	15.85	3.6	1	60
Litres per minute		.219	.264	.06	.016	1

UNITS OF LENGTH

		CONVERT TO →						
		Millimetre	Centimetre	Metre	Kilometre	Inch	Foot	Mile
CONVERT FROM ↓		Multiply By						
Millimetre	mm	1	0.1	0.001	-	0.0394	0.0033	-
Centimetre	cm	10	1	0.01	-	0.394	0.0328	-
Metre	m	1000	100	1	0.001	39.37	3.281	.000621
Kilometre	km	-	-	1000	1	-	3281	0.621
Inch	in	25.4	2.54	0.0254	-	1	0.083	-
Feet	ft	304.8	30.48	0.305	-	12	1	-
Mile	mile	-	-	1610	1.61	-	5280	1

UNITS OF VOLUME

		CONVERT TO →				
		Litre	Kilolitre	Cubic metres	Imperial Gallon	US Gallon
CONVERT FROM ↓		Multiply By				
Litre	lt	1	0.001	0.001	.220	.264
Kilolitre	klt	1000	1	1	220	264
Cubic metre	m ³	1000	1	1	220	264
Imperial Gallon	gal	4.546	0.00454	0.00454	1	1.201
US Gallon (US)	gal	3.785	0.0038	0.0038	0.833	1

Note: The information provided on these pages is for guidance only. Grundfos Pumps Aust Ltd accepts no responsibility for the misuse or misapplication of this information.

POLYETHENE PIPE FRICTION LOSS METRIC (PE63 - AS/NZS 4130)

Flow rate		Friction Loss (metres/100 metres of pipe)							
		OD 32mm 5/32"		OD 40mm 5/16"		OD 50mm 15/32		OD 63mm 25/32"	
L/s	GPM	PN6.3	PN12.5	PN6.3	PN12.5	PN6.3	PN12.5	PN6.3	PN12.5
0.4	5	2.08	3.99	0.73	1.39	0.25	0.48	0.09	0.16
0.5	7	3.07	5.9	1.08	2.05	0.37	0.7	1.13	0.24
0.6	8	4.24	8.14	1.49	2.82	0.51	0.97	0.17	0.32
0.7	9	5.56	10.7	1.95	3.7	0.67	1.27	0.22	0.43
0.8	11	7.05	13.56	2.47	4.69	0.85	1.61	0.28	0.54
0.9	12	8.68	16.72	3.04	5.78	1.04	1.98	0.35	0.66
1	14	10.47	20.17	3.66	6.96	1.26	2.38	0.42	0.8
1.2	16	14.48	27.93	5.06	9.63	1.73	3.29	0.58	1.1
1.4	18	19.07	36.80	6.66	12.67	2.28	4.33	0.75	1.44
1.6	21	24.21	46.76	8.45	16.09	2.89	5.49	0.96	1.83
1.8	24	29.91	57.79	10.42	19.86	3.56	6.77	1.18	2.25
2	26	36.13	69.86	12.58	23.99	4.3	8.17	1.42	2.71
2.5	33	54.00	104.53	18.77	35.82	6.4	12.18	2.11	4.04
3	40	75.05	-	26.05	49.75	8.87	16.89	2.92	5.6
3.5	46	-	-	34.39	65.74	11.69	22.29	3.85	7.38
4	53	-	-	43.77	83.73	14.86	28.35	4.89	9.37
4.5	60	-	-	54.17	-	18.38	35.07	6.04	11.59
5	66	-	-	65.57	-	22.22	42.44	7.3	14.01
5.5	73	-	-	77.96	-	26.40	50.44	8.66	16.63
6	79	-	-	-	-	30.90	59.07	10.13	19.46
6.5	86	-	-	-	-	35.72	68.31	11.70	22.49
7	92	-	-	-	-	40.86	-	13.38	25.72

POLYETHENE PIPE FRICTION LOSS RURAL CLASS B

Flow rate		Friction Loss (metres/100 metres of pipe)				
		¾"	1"	1 ¼"	1 ½"	2"
L/s	GPM					
0.4	5	11.8	2.9	1.0	0.4	0.1
0.5	7	20.8	5.1	1.7	0.7	0.2
0.6	8	-	7.8	2.6	1.1	0.3
0.7	9	-	9.1	3.0	1.3	0.3
0.8	11	-	12.7	4.3	1.7	0.5
0.9	12	-	14.3	4.9	1.9	0.5
1	14	-	18.5	6.2	2.6	0.6
1.2	16	-	27.1	9.5	4.0	1.0
1.4	18	-	31.6	11.1	4.6	1.2
1.6	21	-	-	15.5	6.3	1.5
1.8	24	-	-	17.4	7.1	1.7
2	26	-	-	-	9.6	2.4
2.5	33	-	-	-	13.0	3.4
3	40	-	-	-	-	4.7
3.5	46	-	-	-	-	6.2
4	53	-	-	-	-	8.5
4.5	60	-	-	-	-	9.6
5	66	-	-	-	-	-
5.5	73	-	-	-	-	-
6	79	-	-	-	-	-
6.5	86	-	-	-	-	-
7	92	-	-	-	-	-

PVC PIPE FRICTION LOSS (AS/NZS 1477)

Flow rate		Friction Loss (metres/100 metres of pipe)									
		Nom. 32mm 5/32"		Nom. 40mm 5/16"		Nom. 50mm 15/32		Nom. 80mm 25/32"		Nom. 100mm	
L/s	GPM	PN9	PN12	PN9	PN12	PN9	PN12	PN9	PN12	PN9	PN12
0.4	5	0.48	0.54	0.25	0.29	0.09	0.1	-	-	-	-
0.5	7	0.70	0.80	0.37	0.42	0.13	0.14	-	-	-	-
0.6	8	0.97	1.10	0.51	0.58	0.17	0.2	-	-	-	-
0.7	9	1.27	1.44	0.66	0.77	0.23	0.26	-	-	-	-
0.8	11	1.61	1.82	0.84	0.97	0.29	0.33	-	-	-	-
0.9	12	1.98	2.24	1.03	1.19	0.35	0.4	0.06	0.06	-	-
1	14	2.38	2.70	1.24	1.43	0.42	0.48	0.07	0.08	-	-
1.2	16	3.29	3.74	1.72	1.98	0.59	0.67	0.09	0.11	-	-
1.4	18	4.33	4.91	2.25	2.60	0.77	0.88	0.12	0.14	-	-
1.6	21	5.49	6.23	2.86	3.30	0.97	1.11	0.15	0.18	-	0.05
1.8	24	6.77	7.68	3.52	4.06	1.20	1.37	0.19	0.22	0.06	0.06
2	26	8.17	9.27	4.25	4.90	1.45	1.65	0.23	0.26	0.07	0.08
2.5	33	12.18	13.83	6.33	7.30	2.15	2.45	0.34	0.39	0.1	0.12
3	40	16.89	19.18	8.77	10.12	2.97	3.4	0.46	0.53	0.14	0.16
3.5	46	22.29	-	11.56	13.35	3.92	4.47	0.61	0.70	0.18	0.21
4	53	-	-	14.7	16.98	4.98	5.68	0.77	0.89	0.23	0.26
4.5	60	-	-	18.18	20.99	6.15	7.02	0.95	1.1	0.29	0.33
5	66	-	-	-	-	7.43	8.49	1.15	1.32	0.34	0.39
5.5	73	-	-	-	-	8.82	10.07	1.37	1.57	0.41	0.47
6	79	-	-	-	-	10.32	11.78	1.60	1.83	0.48	0.55
7	92	-	-	-	-	13.62	15.59	2.11	2.42	0.63	0.72
8	106	-	-	-	-	-	19.82	2.68	3.07	0.8	0.91
9	119	-	-	-	-	-	24.54	3.31	3.8	0.98	1.13
10	132	-	-	-	-	-	29.71	4.0	4.59	1.19	1.36
11	145	-	-	-	-	-	-	4.75	5.46	1.41	1.62
12	158	-	-	-	-	-	-	5.56	6.39	1.65	1.89



be think innovate

Grundfos Pumps Pty Ltd
515 South Road
Regency Park SA 5010
Australia
Phone (08) 8461 4608
Fax (08) 8340 0155
contact-au@grundfos.com
www.grundfos.com.au

GRUNDFOS 

The name Grundfos, the Grundfos logo, and be think innovate are registered trademarks owned by Grundfos Holding A/S or Grundfos A/S, Denmark. All rights reserved worldwide.

GPM00690 07/14