



Construction

Close-coupled gear pumps (rotary pumps).
Pump casing with suction and delivery connections with the same diameter and on the same axis (in-line execution).

Applications

For fuel oil and liquids with lubricating properties.

Operating conditions

Kinematic viscosity from 30 mm²/s (4°E) to 120 mm²/s (15°E).
Liquid temperature up to 90 °C.
Ambient temperature up to 40 °C.
Total suction lift up to 4 m.
Continuous duty.

Motor

4-pole induction motor, 50 Hz (n ≈ 1450 rpm).

I, IR, IRR: three-phase 230/400 V ± 10%.

IM: single-phase 230 V ± 10%.

Insulation class F.

Protection IP 54.

Classification scheme IE3 for three-phase motors from 0,75 kW.

Constructed in accordance with: EN 60034-1; EN 60034-30.
EN 60335-1, EN 60335-2-41.

Special features on request

- Other voltages.
- Frequency 60 Hz (as per 60 Hz data sheet).
- Protection IP 55.
- Higher ambient temperatures.

Materials

Components	Materials
Pump casing	Cast iron GJL 200 EN 1561
Gears	Steel 18 Ni Cr Mo 5 UNI 8550
Shafts	Steel 18 Ni Cr Mo 5 UNI 8550
Radial shaft seal ring	FPM

Performance n ≈ 1450 rpm

	3 ~ 230 V 400 V		1 ~ 230 V		P ₁ kW	P ₂		n rpm	Q m ³ /h l/min	Δp bar
	A	A	A	kW		kW	HP			
I	25/4/A	1,4	0,8	IM25/4/A	2,1	0,4	0,25	0,34	1450	2
IR	25/4/A	2,1	1,2				0,37	0,5	1450	2,5
IRR	25/4/B	3,3	1,9				0,75	1	1450	5

P₁ Max. power input.

P₂ Rated motor power output.

Δp Differential pressure.

Dimensions and weights

- I 25/4/A:** 10 kg
- IM 25/4/A:** 11,7 kg
- IR 25/4/A:** 11,6 kg

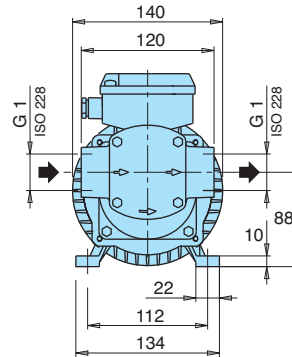
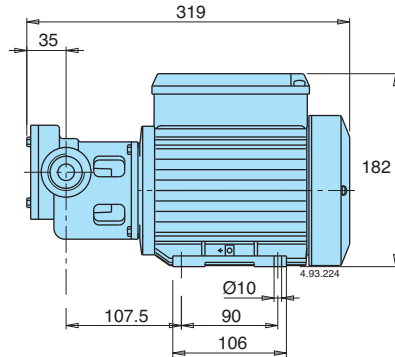

- IRR 25/4/B:** 17,6 kg

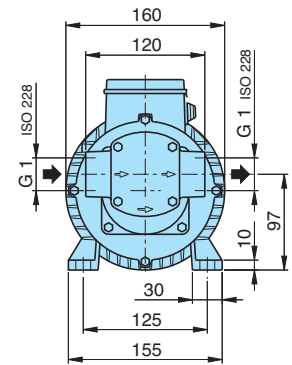
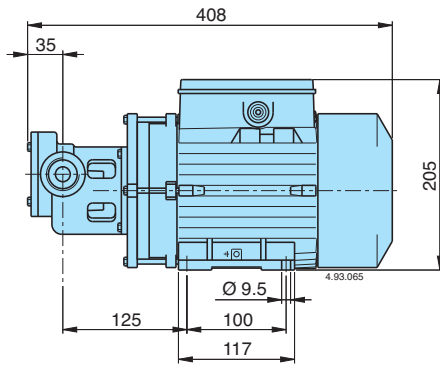

Features

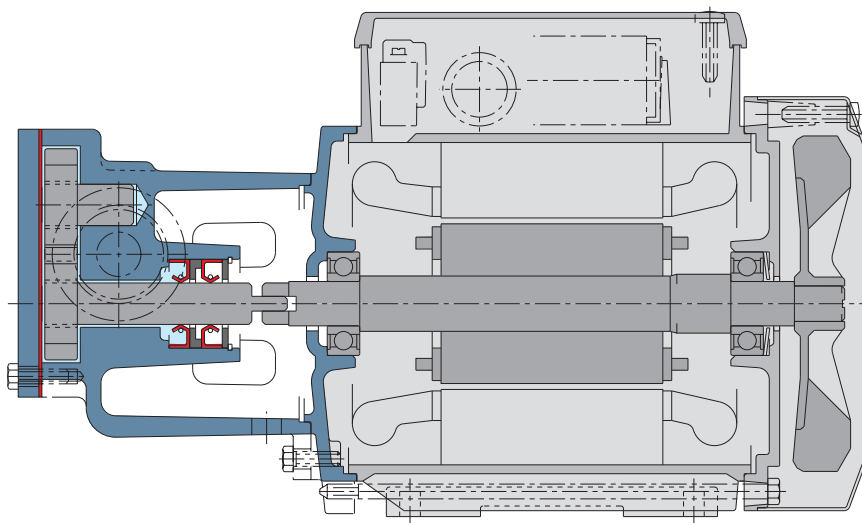

Innovative structure

The flanged pump casing and two piece shaft allows the hydraulics to be disassembled easier, facilitating quick maintenance operations.