

Ran[®] 1/4" (6.35 mm)

Polypropylene Body Diaphragm Pump



Technical Specifications

Pump Code	A8-P1-1
Max. Flow Rate	15 lpm
Max. Pump Speed	250 cpm
Displacement per cycle	0.06 liter
Fluid Inlet- Outlet Size	1/4" NPT
Air Inlet Size	1/8"
Max. Fluid Working Pressure	8 bar
Max. Air Consumption (at 5 bar)	8.4 m ³ /h
Ratio	1:1

Pump Housing Material	Polypropylene
Center Section Material	Polypropylene
Max. Size Pumpable Solids	1 mm
Max. Suction Lift	9.5 m (Wet) 2.5 m (Dry)
Max. Operating Temperature	80 °C
Sound Level	61 dBA (at 5 bar)
Diaphragm Material	PTFE
Check-Valve Material	PTFE
Weight	1.25 kg

Performance Curves

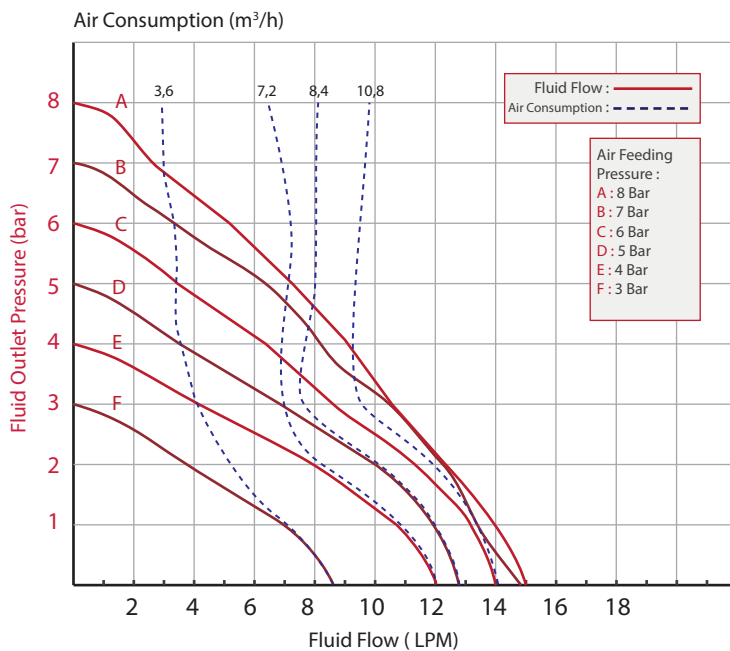

Made in Turkey



Test Conditions: All tests are made with water. Suction hose submerged in the fluid. Muffler not used. All the values are shown are approximate and not binding.

Example: To pump 7 lpm against a discharge pressure of 3 bar, requires 5 bar and 7.2 m³/h air consumption.

Dimensions

A	155
B	104
C	230
D	104.5
E	123
F	70
G	7

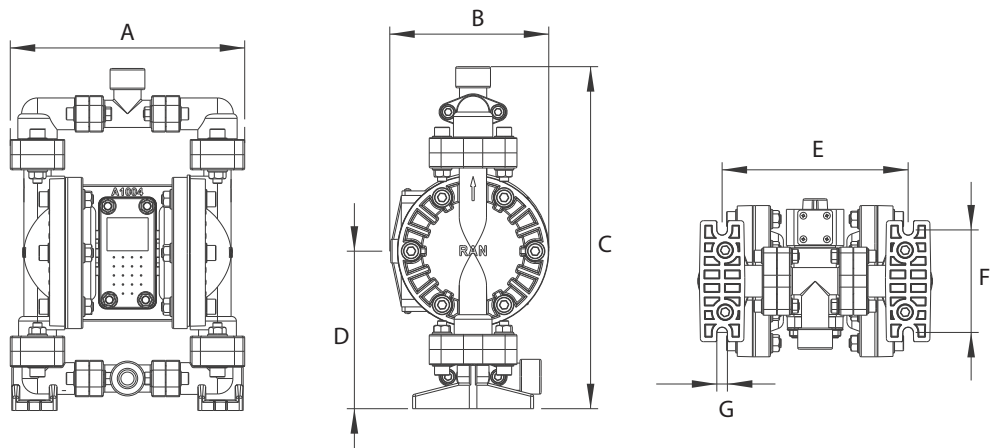

All dimensions are in mm.