

# Ran® 1/2" (12.7 mm)

## Aluminium Body Diaphragm Pump



### Technical Specifications

Pump Code	B15-A3-2
Max. Flow Rate	70 lpm
Max. Pump Speed	400 cpm
Displacement per cycle	0.18 liter
Fluid Inlet- Outlet Size	1/2" NPT
Air Inlet Size	1/4"
Max. Fluid Working Pressure	8 bar
Max. Air Consumption (at 5 bar)	24 m <sup>3</sup> /h
Ratio	1:1

Pump Housing Material	Aluminium
Center Section Material	Polypropylene
Max. Size Pumpable Solids	2 mm
Max. Suction Lift	7.5 m (Wet) 3.5 m (Dry)
Max. Operating Temperature	80 °C
Sound Level	65 dBa (at 5 bar)
Diaphragm Material	Hytrel
Check-Valve Material	Acetal ball & Hytrel seat
Weight	3.6 kg

### Performance Curves

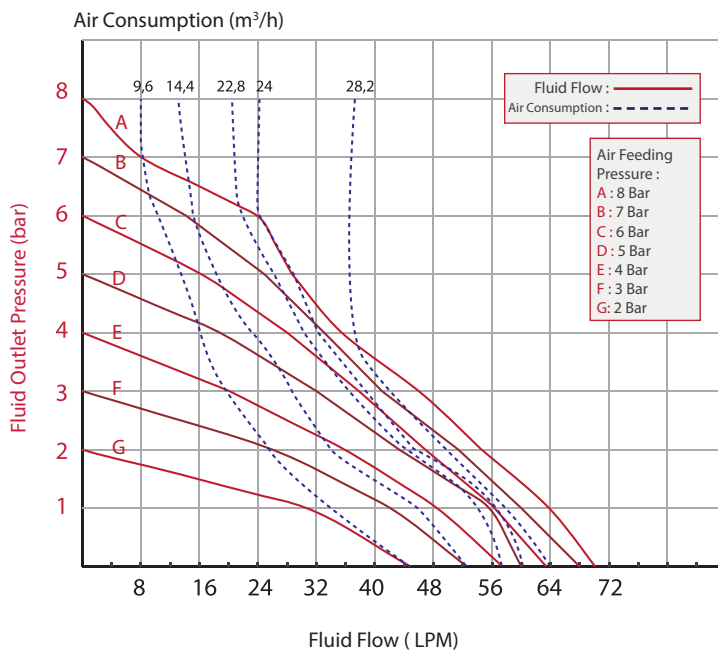

**Made in Turkey**



**Test Conditions:** All tests are made with water. Suction hose submerged in the fluid. Muffler not used. All the values are shown are approximate and not binding.

**Example:** To pump 45 lpm against a discharge pressure of 2.7 bar, requires 7 bar and 28.2 m<sup>3</sup>/h air consumption.

### Dimensions

A	194
B	274
C	150
D	220
E	32
F	152
G	100
H	9

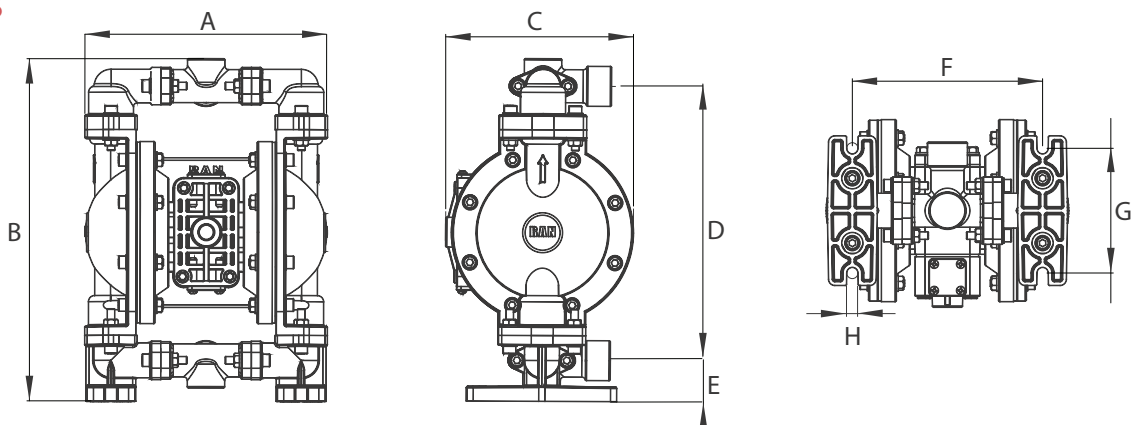

All dimensions are in mm.