

## X 4.40 DV

### Rotary vane pressure/vacuum pumps – for x-tra operating hours

- oil-free and air-cooled
- incl. integrated suction filter and pressure and vacuum regulating valve

### Drehschieber-Druck-Vakuumpumpen – für x-tra Betriebsstunden

- trockenlaufend und luftgekühlt
- inkl. integriertem Ansaugfilter und Druck- und Vakuumregulierventil

### Pompes combinées à palettes – pour le heures de travail x-tra

- fonctionnant à sec et refroidies par air
- incl. filtre d'aspiration intégré et soupape de réglage pression et de vide

### Pompe combinata a palette – per x-tra ore operative

- funzionanti a secco e raffreddate ad aria
- incl. filtro di aspirazione integrato e valvola regolazione pressione e vuoto

### Bombas combinadas de paletas – para las horas de funcionamiento x-tra

- sin aceite y refrigerado por aire
- incl. filtro de aspiración integrado y válvula reguladora de presión y vacío

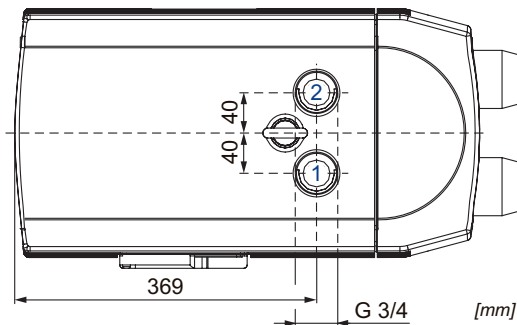
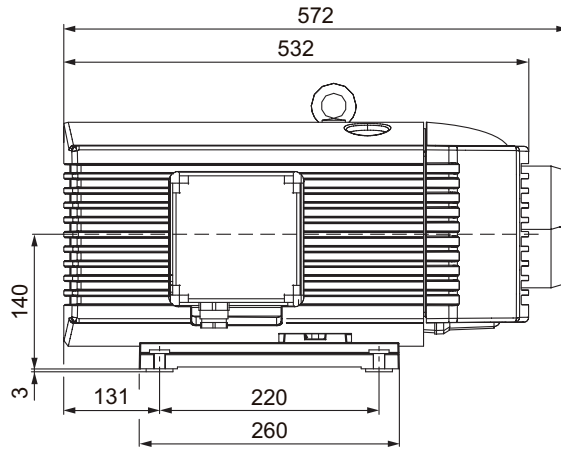
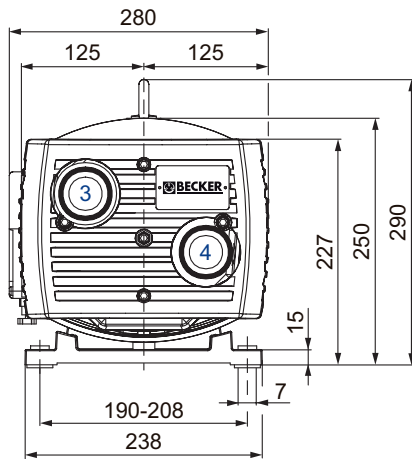

- |  |  |
|--|--|
| 1 Vacuum connection<br>Sauganschluss<br>Raccord vide<br>Raccordo aspirazione<br>Conexión de vacío        | 3 Vacuum regulating valve<br>Vakuumregulierventil<br>Soupape de regulage vide<br>Valvola regolazione vuoto<br>Válvula reguladora de vacío            |
| 2 Pressure connection<br>Druckanschluss<br>Raccord pression<br>Raccordo pressione<br>Conexión de presión | 4 Pressure regulating valve<br>Druckregulierventil<br>Soupape de regulage pression<br>Valvola regolazione pressione<br>Válvula reguladora de presión |

m <sup>3</sup> /h		bar rel.		kg	dB(A) <sup>1)</sup>	
50 Hz	60 Hz	50 Hz	60 Hz		50 Hz	60 Hz
35	43	±0.5	±0.5	38.5	66	68

M	50 Hz				60 Hz				IP54 • ISO F • ...	№	№ X 4.40 DV
	kW	V	min <sup>-1</sup>	A	kW	V	min <sup>-1</sup>	A			
3~	1.25	190-255/330-440	1430	5.2-6.2/3.0-3.6	1.5	190-290/330-500	1680	6.9-5.7/4.0-3.3	... bi-metal 150°C	41914498276	G014310
1~	1.1	230 ±10%	1350	7.6	1.1	230 ±10%	1620	7.3	... bi-metal 150°C • 30 µF / 400 V	41824402276	

- |  |  |  |  |   |
|--|--|--|--|---|
| 1) DIN EN ISO 3744 (KpA = 3 dB(A))<br>interval of 1m, at medium load, both<br>connection sides piped | DIN EN ISO 3744 (KpA = 3 dB(A))<br>Abstand von 1m, bei mittlerer<br>Belastung, beide Seiten abgeleitet | DIN EN ISO 3744 (KpA = 3 dB(A))<br>intervalle de 1m, à régime moyen,<br>avec dérivation des deux côtés | DIN EN ISO 3744 (KpA = 3 dB(A))<br>intervallo di 1m, a medio regime,<br>entrambi i lati derivati | DIN EN ISO 3744 (KpA = 3 dB(A))<br>intervalo de 1m, en media carga,<br>derivados de ambos lados |
| • Dimensions in mm   | Maßangaben in mm   | Mesures en mm  | Misure in mm   | Dimensiones en mm   |



WWW.BECKER-INTERNATIONAL.COM

Right of modification reserved  
Änderungen vorbehalten  
Sous réserve des modifications  
Sotto riserva di modificazioni  
Derecho a modificaciones reservado 07.06.2017

Pressure Druck Pression Pressione Presión [bar rel. <sup>1)</sup> ]		Vacuum • Vakuüm • Vide • Vuoto • Vacío [bar rel. <sup>1)</sup> ]					
		50 Hz			60 Hz		
		0 bar	-0.25 bar	-0.5 bar	0 bar	-0.25 bar	-0.5 bar
<b>+0.25 bar</b>	Suction air rate Saugluftmenge Débit d'air aspiré Volume d'aria aspirata Volumen de aire aspirado [m <sup>3</sup> /h]	35.88	25.77	14.9	42.49	30.39	16.53
	Blast air rate Blasluftmenge Débit d'air soufflé Volume d'aria soffiata Volumen de aire soplado [m <sup>3</sup> /h]	35.88	25.77	14.9	42.49	30.39	16.53
	Power consumption Leistungsaufnahme puissance absorbée Potenza assorbita potencia absorbida [kW]	0.97	0.97	1	1.28	1.25	1.25
	Temperature compressed air Blaslufttemperatur Température d'aria comprimé Temperatura aria compressa Temperatura de aire comprimido [°C]	68	77	90	76	84	101
<b>+0.5 bar</b>	Suction air rate Saugluftmenge Débit d'air aspiré Volume d'aria aspirata Volumen de aire aspirado [m <sup>3</sup> /h]	34.16	23.95	13.48	41.13	29.26	13.48
	Blast air rate Blasluftmenge Débit d'air soufflé Volume d'aria soffiata Volumen de aire soplado [m <sup>3</sup> /h]	34.16	23.95	13.48	41.13	29.26	13.48
	Power consumption Leistungsaufnahme puissance absorbée Potenza assorbita potencia absorbida [kW]	1.1	1.13	1.17	1.45	1.44	1.46
	Temperature compressed air Blaslufttemperatur Température d'aria comprimé Temperatura aria compressa Temperatura de aire comprimido [°C]	77	89	101	83	95	110

1) bar relative	bar relativ	bar relatif	bar relativo	bar relativa	1000 mbar, 20°C
▪ Reference data (atmosphere)	Bezugsdaten (Atmosphäre)	Référence (atmosphère)	Riferimento (atmosfera)	Referencia (atmosférica)	
▪ Blast air rate measured at suction side.	Blasluftmenge saugseitig gemessen.	Débit d'air soufflé calibré au côté d'aspiration.	Volume d'aria soffiata collaudata sul lato aspirazione.	Volumen de aire soplado medida en el lado de succión.	
▪ Tolerance	Toleranz	Tolérance	Tolleranza	Tolerancia	±5 %

Variants/Accessories	Varianten/Zubehör	Variantes/Accessoires	Varianti/Accessori	Variantes/Accesorios	i
- with external suction filter - in sound proof box SH 19 - with compressed air cooler (X 4.40 DSK → ±0.6 bar) - as standard pump (T 4.40 DV)	- mit externem Ansaugfilter - in Schallhaube SH 19 - mit Druckluftkühler (X 4.40 DSK → ±0.6 bar) - als Standardpumpe (T 4.40 DV)	- avec filtre d'aspiration externe - dans caisse d'insonorisation SH 19 - avec refroidisseur (X 4.40 DSK → ±0.6 bar) - comme une pompe standard (T 4.40 DV)	- con filtro di aspirazione esterno - in casse insonorizzanti SH 19 - con raffreddatore (X 4.40 DSK → ±0.6 bar) - come una pompa standard (T 4.40 DV)	- con filtro de aspiración externo - en caja a prueba de sonido SH 19 - con refrigerador de aire comprimido (X 4.40 DSK → ±0.6 bar) - como una bomba estándar (T 4.40 DV)	
Performance data / dimensions can differ Combinations on request	Leistungsdaten / Abmessungen können abweichen Kombinationen auf Anfrage	Données de performance / mesures peuvent différer Combinaisons sur demande	Dati di performance / misure possono differire Combinazioni su richiesta	Datos de rendimiento / dimensiones pueden diferir Combinaciones a petición	