

Cast Iron Body Diaphragm Pump



Technical Specifications

Pump Code	EXE40M-C1-1	Pump Housing Material	Cast Iron
Max. Flow Rate	290 lpm	Center Section Material	Aluminium
Max. Pump Speed	200 cpm	Max. Size Pumpable Solids	4.5 mm
Displacement per cycle	1.45 liter	Max. Suction Lift	9.5 m (Wet) 5 m (Dry)
Fluid Inlet- Outlet Size	1 1/2" NPT	Max. Operating Temperature	104 °C
Air Inlet Size	1/2"	Sound Level	78 dBa (at 5 bar)
Max. Fluid Working Pressure	8 bar	Diaphragm Material	PTFE
Max. Air Consumption (at 5 bar)	1.7 m ³ /min	Check-Valve Material	Acetal
Ratio	1:1	Weight	41 kg

Performance Curves

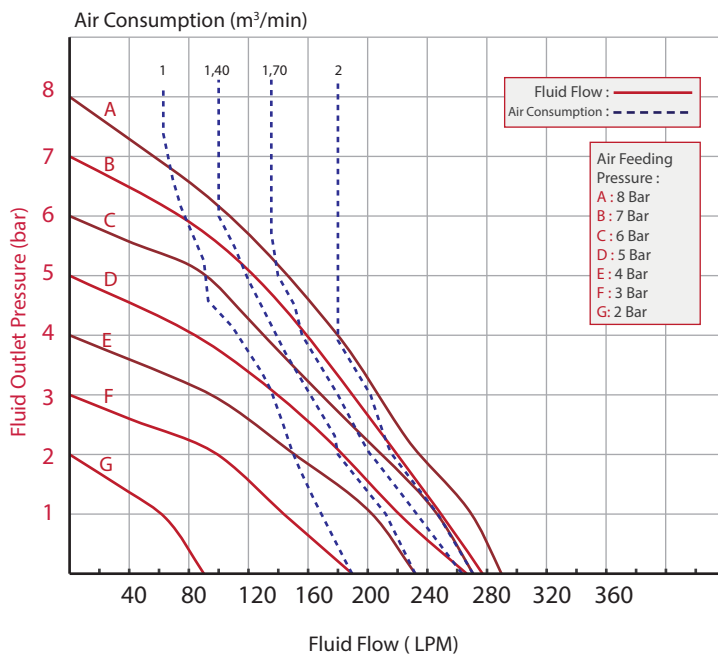

Made in Turkey



ATEX II 2gd IIb t135

Test Conditions: All tests are made with water. Suction hose submerged in the fluid. Muffler not used. All the values are shown are approximate and not binding.

Example: To pump 160 lpm against a discharge pressure of 4 bar, requires 7 bar and 1,7 m³/min air consumption.

Dimensions

A	407
B	402
C	50
D	260.5
E	490
F	280
G	312
H	156
I	12

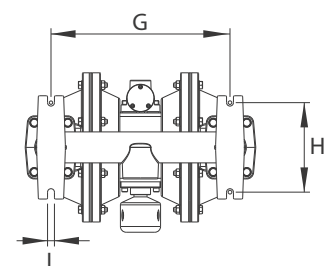
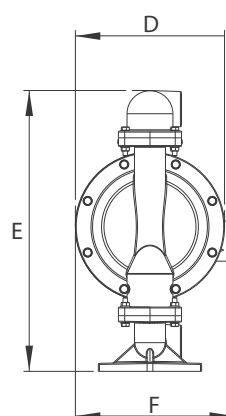
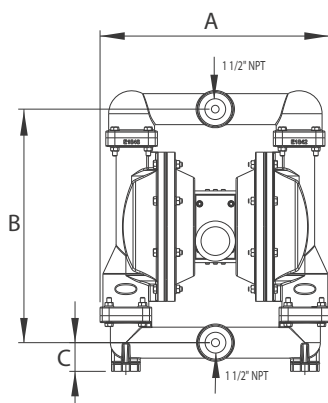

All dimensions are in mm.