

Ran[®] 2" (50.8 mm)

316 Stainless Steel Body
Diaphragm Pump

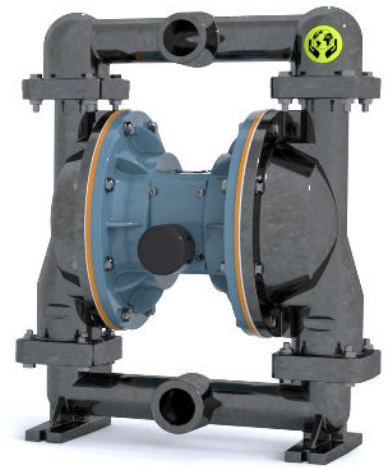

Technical Specifications

Pump Code	EXF50M-SCS
Max. Flow Rate	596 lpm
Max. Pump Speed	145 cpm
Displacement per cycle	4.11 liter
Fluid Inlet- Outlet Size	2" NPT
Air Inlet Size	1/2"
Max. Fluid Working Pressure	8 bar
Max. Air Consumption (at 5 bar)	2.3 m ³ /min
Ratio	1:1

Pump Housing Material	316 Stainless Steel
Center Section Material	Aluminium
Max. Size Pumpable Solids	6.2 mm
Max. Suction Lift	9.5 m (Wet) 6 m (Dry)
Max. Operating Temperature	100 °C
Sound Level	82 dBa (at 5 bar)
Diaphragm Material	TPE
Check-Valve Material	TPE
Weight	65.5 kg

Performance Curves

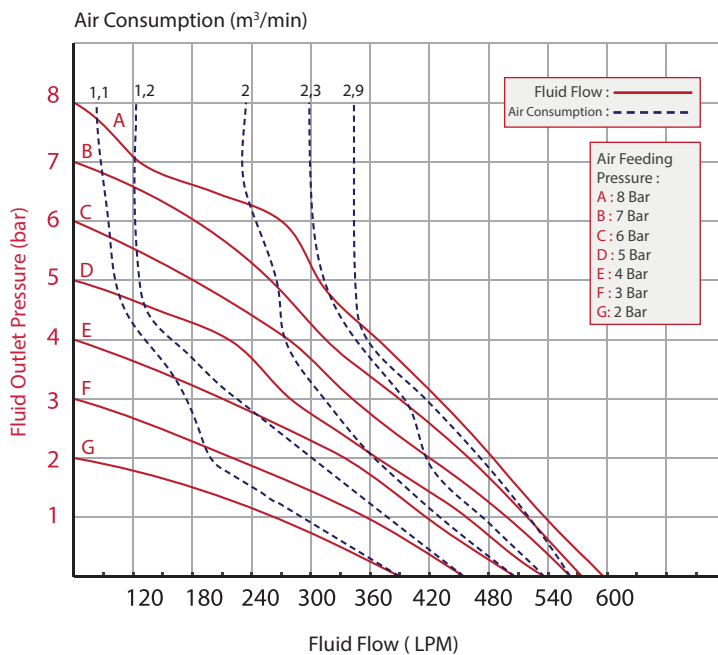

40% less air consumption thanks to **ECO+** series...



ATEX II 2gd IIB t135

Test Conditions: All tests are made with water. Suction hose submerged in the fluid. Muffler not used. All the values are shown are approximate and not binding.

Example: To pump 392 lpm against a discharge pressure of 3 bar, requires 7 bar and 2,3 m³/min air consumption.

Dimensions

A	507
B	407
C	322
D	622
E	375
F	192
G	12

All dimensions are in mm.

