

EBARA

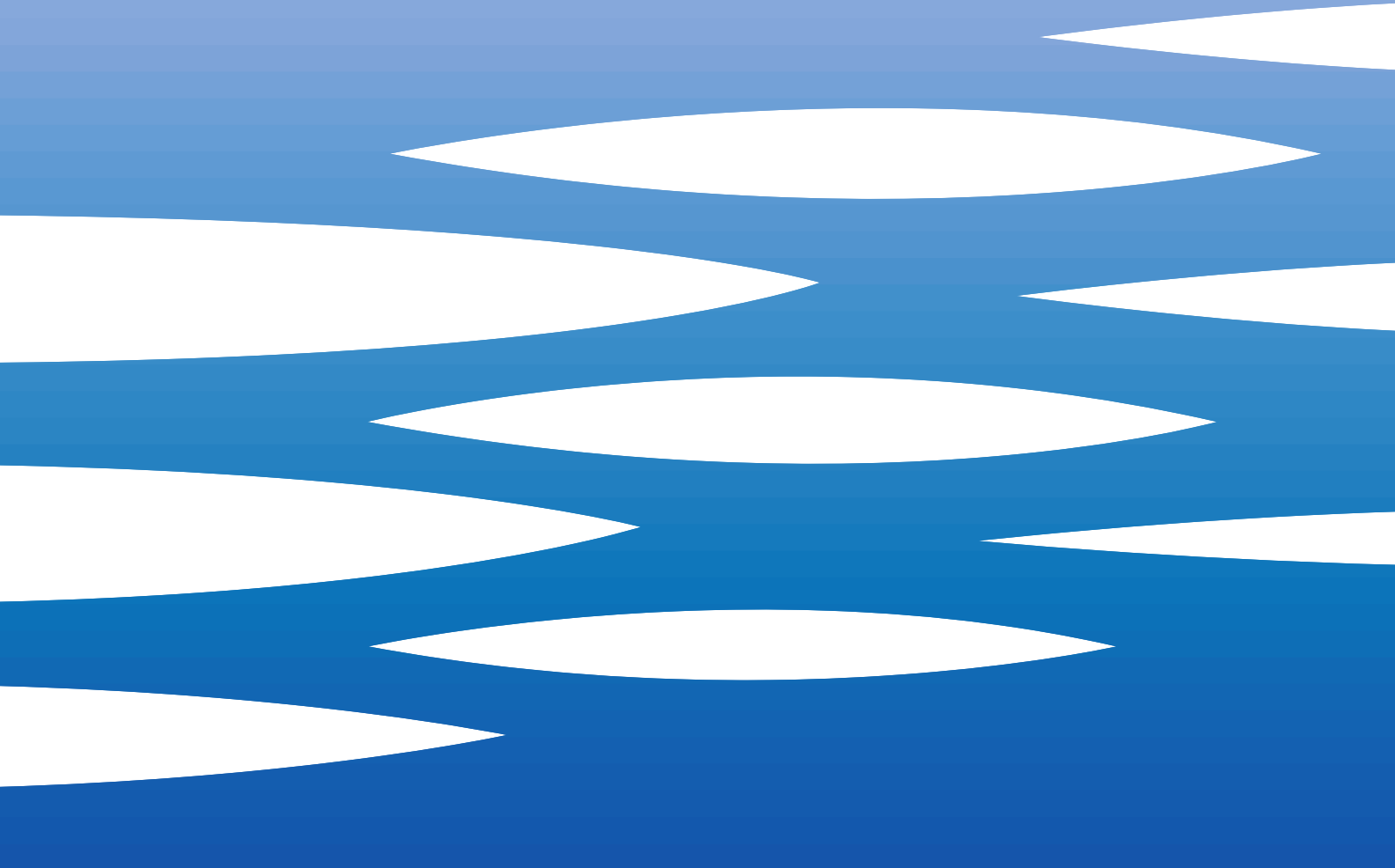

	Page
- SPECIFICATIONS	200
SELECTION CHART	201
SELECTION CHART	202
PERFORMANCE CHART CMA 0.50	203
PERFORMANCE CHART CMA 0.75	204
PERFORMANCE CHART CMA 0.80	205
PERFORMANCE CHART CMA 1.00	206
PERFORMANCE CHART CMA 1.50	207
PERFORMANCE CHART CMA 2.00	208
PERFORMANCE CHART CMA 3.00	209
PERFORMANCE CHART CMB 0.75	210
PERFORMANCE CHART CMB 1.00	211
PERFORMANCE CHART CMB 1.50	212
PERFORMANCE CHART CMB 2.00	213
PERFORMANCE CHART CMB 3.00	214
PERFORMANCE CHART CMB 4.00	215
PERFORMANCE CHART CMB 5.50	216
PERFORMANCE CHART CMC 0.75	217
PERFORMANCE CHART CMC 1.00	218
PERFORMANCE CHART CMD 1.50	219
PERFORMANCE CHART CMD 2.00	220
PERFORMANCE CHART CMD 3.00	221
PERFORMANCE CHART CMD 4.00	222
- CONSTRUCTIONS	300
SECTIONAL VIEW MODELS UP TO 1.00	300
SECTIONAL VIEW MODELS 1.50 AND OVER	301
MECHANICAL SEAL UP TO 1.00	302
MECHANICAL SEAL 1.50 AND OVER	303
THREE PHASE DIAGRAM AND ELECTRIC CONNECTIONS	304
SINGLE PHASE DIAGRAM AND ELECTRIC CONNECTIONS	305
- DIMENSIONS	400
DIMENSIONS	401
PACKING AND WEIGHT	402
- TECHNICAL DATA	500

CENTRIFUGAL PUMPS

CMA-B-C-D

SPECIFICATIONS

50Hz

PUMP		
Liquid	Type of liquid	Clean water
Handled	Max temperature [°C]	40 (CMA up to 1.00)
		90 (the other)
Maximum working pressure	[MPa]	0.6 (CMA up to 1.00 ; CMB up to 3.00; CMC CMD)
		0.8 (the other)
Construction	Impeller	Closed centrifugal
	Shaft seal type	Mechanical seal
	Bearing	Sealed ball bearing
Pipe Connection	Suction	G 1" (CMA up to 1.00) UNI ISO 228 G 1"¼ (CMA 1.50 and over) UNI ISO 228 G 2" (CMB - CMC) UNI ISO 228 G 2"½ (CMD) UNI ISO 228
	Discharge	G 1" (CMA) UNI ISO 228 G 1"¼ (CMB) UNI ISO 228 G 2" (CMC) UNI ISO 228 G 2"½ (CMD) UNI ISO 228
Material	Casing	Cast iron
	Impeller	PPO mod. glass fibre reinforced - Brass - Cast iron see application page 300
	Shaft seal	Ceramic/Carbon/NBR
	Shaft	AISI 416 - AISI 303 - AISI 304 see application page 300
	Bracket	Cast iron - Aluminium see application page 300
	Casing cover	AISI 304 see application page 300
Applicable standard of test		ISO 9906 – Annex A

MOTOR		
Type	Electric - TEFC	
	Single Phase	Three Phase
No. Of Poles	2	
Synchronous speed [min ⁻¹]	3000	
Insulation Class	F	
Protection degree	IP 44	
Power rating	[kW]	0.37 ÷ 1.5
	[HP]	0.5 ÷ 2
Frequency	[Hz]	50 Hz
Voltage	[V]	230V ±10%
Capacitor	Built in	-
Over load protection	Built in	Provided by the user
Casing material	Aluminium	
Base material / motor support	Aluminium / Cast iron / Plastic foot	
Dimensions of cable entry	PG11 - PG13.5 – PG16 (see dimensions page 401)	

CENTRIFUGAL PUMPS

CMA-B-C-D

SELECTION CHART

50 Hz

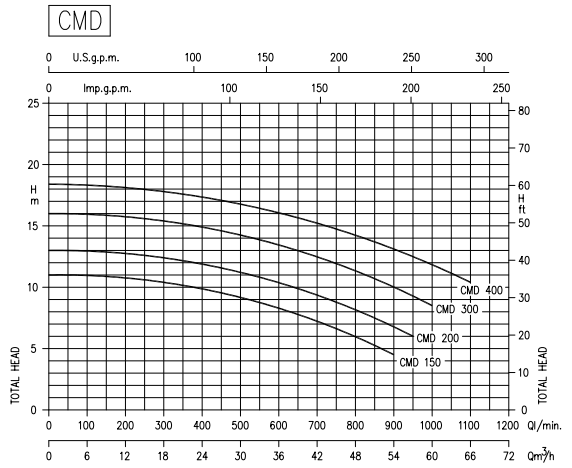
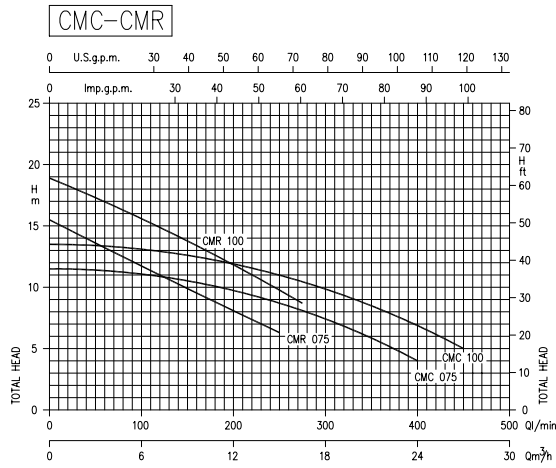
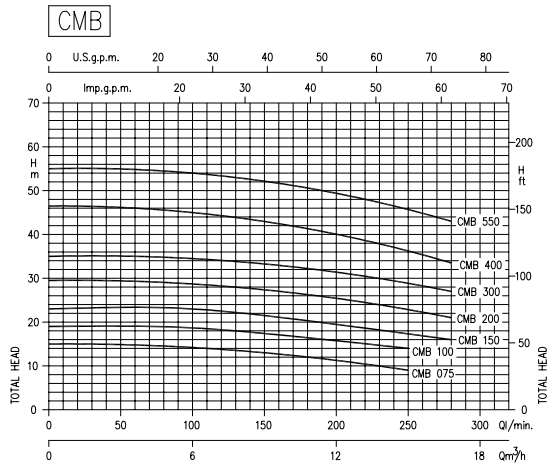
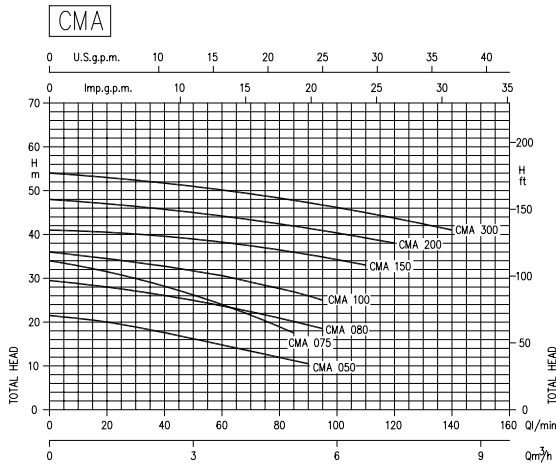

TYPE KEY:

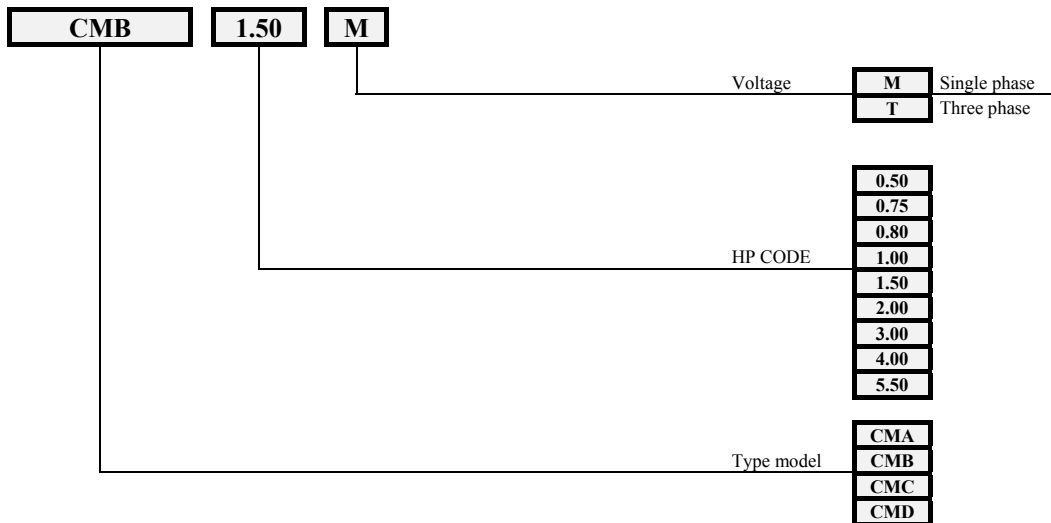

CENTRIFUGAL PUMPS

CMA-B-C-D

SELECTION CHART

50Hz

Type pumps		kW	HP	Q=Capacity											
Single phase	Three phase			l/min	20	40	60	80	85	90	95	100	110	120	140
230 V	230/400 V			m ³ /h	1.2	2.4	3.6	4.8	5.1	5.4	5.7	6	6.6	7.2	8.4
50 Hz		50 Hz	H=Total manometric head in meters												
CMA 0.50 M	CMA 0.50 T	0.37	0.5	20	17.8	15	12.1	11.2	10.5	-	-	-	-	-	
CMA 0.75 M	CMA 0.75 T	0.55	0.75	31.5	28.2	24	18.9	17.5	-	-	-	-	-	-	
CMA 0.80 M	CMA 0.80 T	0.6	0.8	28	26.1	23.8	20.9	20.1	19.3	18.5	-	-	-	-	
CMA 1.00 M	CMA 1.00 T	0.75	1	34.5	32.8	30.6	27.7	26.9	26	25	-	-	-	-	
CMA 1.50 M	CMA 1.50 T	1.1	1.5	40.5	39.6	38.2	36.5	36	35.6	34.9	34.3	33	-	-	
CMA 2.00 M	CMA 2.00 T	1.5	2	47	45.8	44.2	42.4	41.9	41.4	40.9	40.3	39.2	38	-	
-	CMA 3.00 T	2.2	3	53	51.8	50.2	48.3	47.8	47.3	46.7	46.2	45	43.7	41	

Type pumps		kW	HP	Q=Capacity						
Single phase	Three phase			l/min	100	140	180	220	250	280
230 V	230/400 V			m ³ /h	6	8.4	10.8	13.2	15	16.9
50 Hz		50 Hz	H=Total manometric head in meters							
CMB 0.75 M	CMB 0.75 T	0.55	0.75	14.2	13.3	12	10.4	9	-	
CMB 1.00 M	CMB 1.00 T	0.75	1	18.4	17.4	16.1	15.2	14	-	
CMB 1.50 M	CMB 1.50 T	1.1	1.5	22.4	21.1	19.8	18.0	17.1	16	
CMB 2.00 M	CMB 2.00 T	1.5	2	28.7	27.7	26.3	24.5	22.8	21	
-	CMB 3.00 T	2.2	3	34.5	33.7	32.1	30.3	28.8	27	
-	CMB 4.00 T	3	4	45	43.4	41.5	38.4	36.2	33.5	
-	CMB 5.50 T	4	5.5	54	52.3	50.4	48.1	45.7	43	

Type pumps		kW	HP	Q=Capacity						
Single phase	Three phase			l/min	50	150	250	350	400	450
230 V	230/400 V			m ³ /h	3	9	15	21	24	27
50 Hz		50 Hz	H=Total manometric head in meters							
CMC 0.75 M	CMC 0.75 T	0.55	0.75	11.4	10.6	8.8	5.9	4	-	
CMC 1.00 M	CMC 1.00 T	0.75	1	13.4	12.6	11	8.6	6.8	5	

Type pumps		kW	HP	Q=Capacity								
Single phase	Three phase			l/min	300	400	600	800	900	950	1000	1100
230 V	230/400 V			m ³ /h	18	24	36	48	54	57	60	66
50 Hz		50 Hz	H=Total manometric head in meters									
CMD 1.50 M	CMD 1.50 T	1.1	1.5	10.4	9.9	8.4	6	4.5	-	-	-	
CMD 2.00 M	CMD 2.00 T	1.5	2	12.4	11.9	10.5	8.3	6.8	6	-	-	
-	CMD 3.00 T	2.2	3	15.4	14.9	13.5	11.4	10	9.3	8.5	-	
-	CMD 4.00 T	3	4	17.8	17.3	16.1	14.2	13.1	12.5	11.8	10.4	

CENTRIFUGAL PUMPS

CMA-B-C-D

PERFORMANCE CURVE

50Hz

CMA 0.50 (0.37 kW)
SYNCHRONOUS SPEED: 3000 min⁻¹

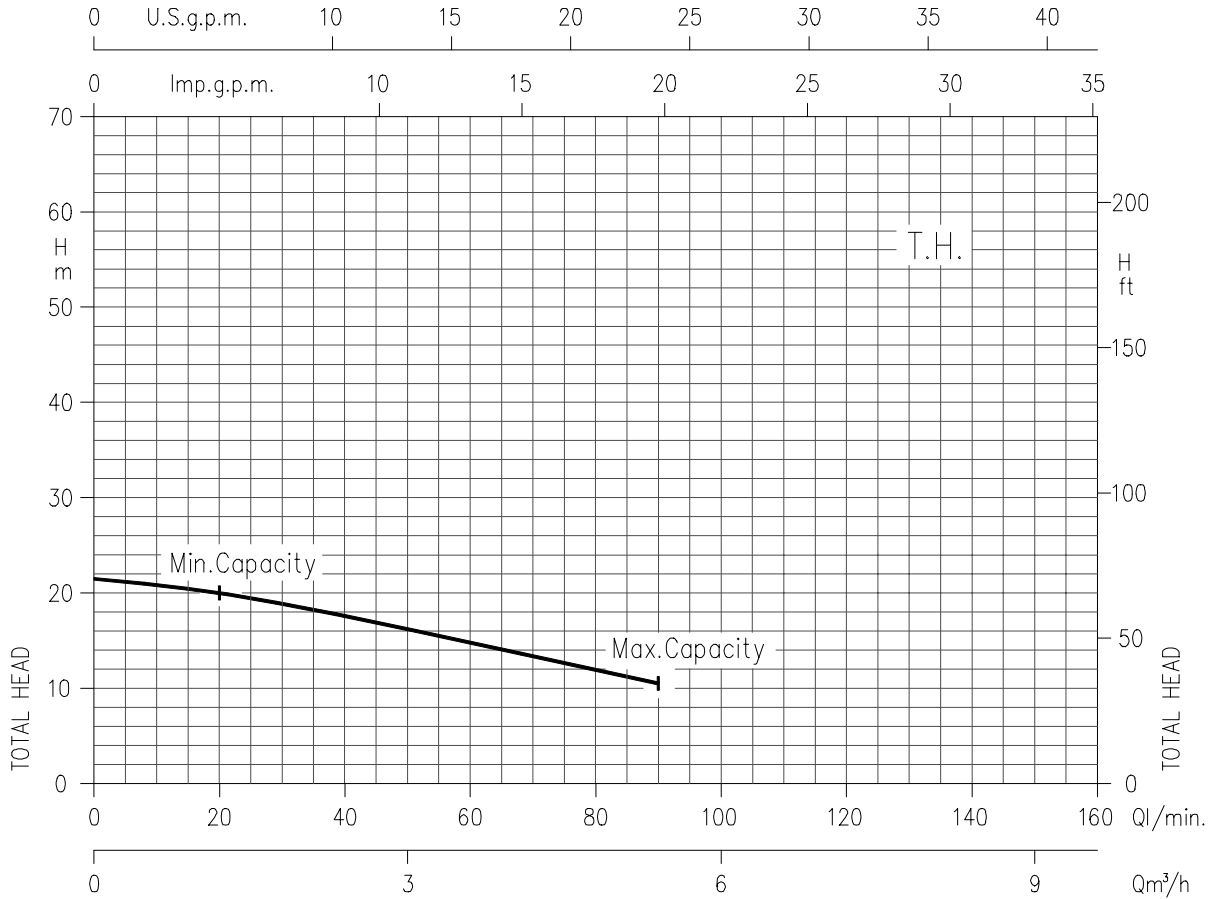

Temperature of water: 20°C
Impeller diameter = 130 mm
Applicable standard of test: ISO 9906-Annex A

CENTRIFUGAL PUMPS

CMA-B-C-D

PERFORMANCE CURVE

50Hz

CMA 0.75 (0.55 kW)
SYNCHRONOUS SPEED: 3000 min⁻¹

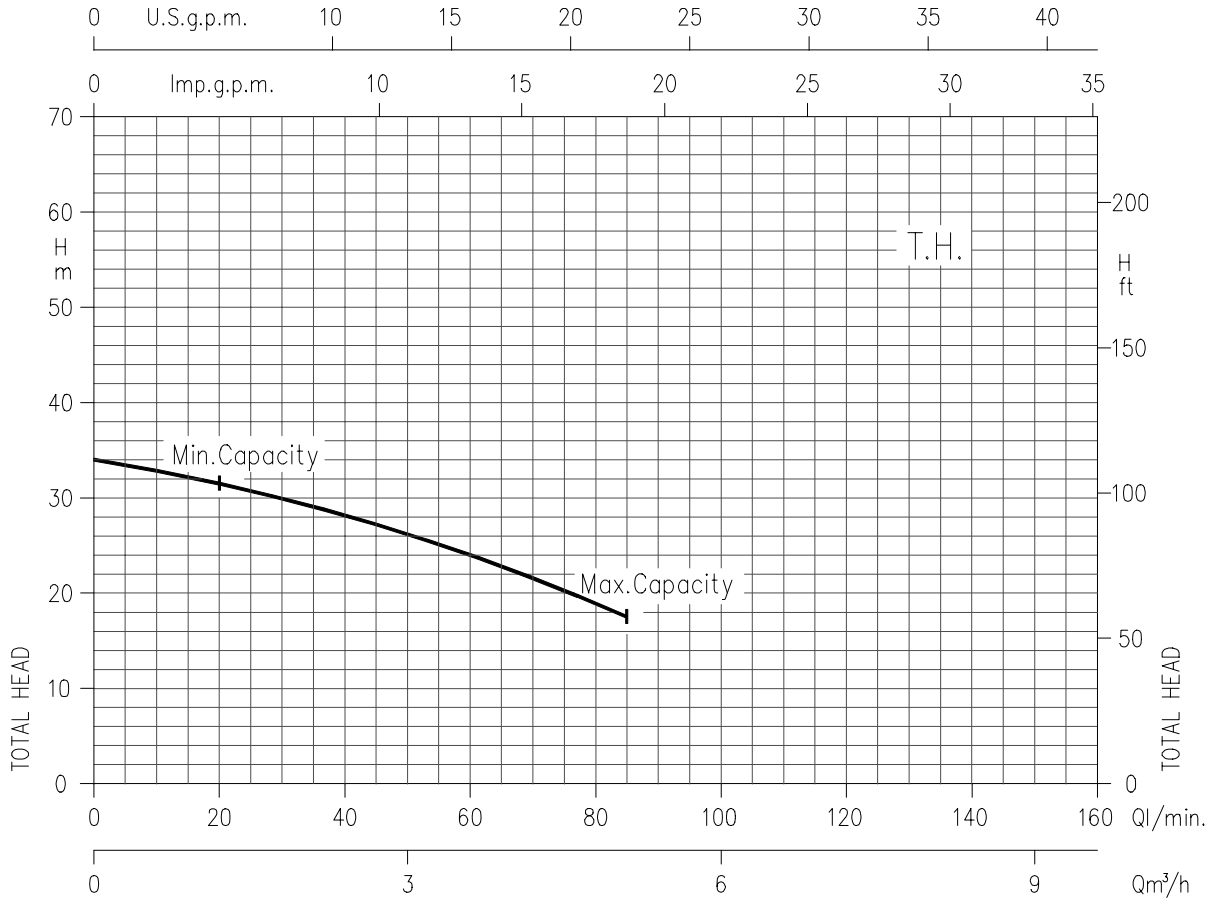

Temperature of water: 20°C
Impeller diameter = 161 mm
Applicable standard of test: ISO 9906-Annex A

CENTRIFUGAL PUMPS

CMA-B-C-D

PERFORMANCE CURVE

50Hz

CMA 0.80 (0.6 kW)
SYNCHRONOUS SPEED: 3000 min⁻¹

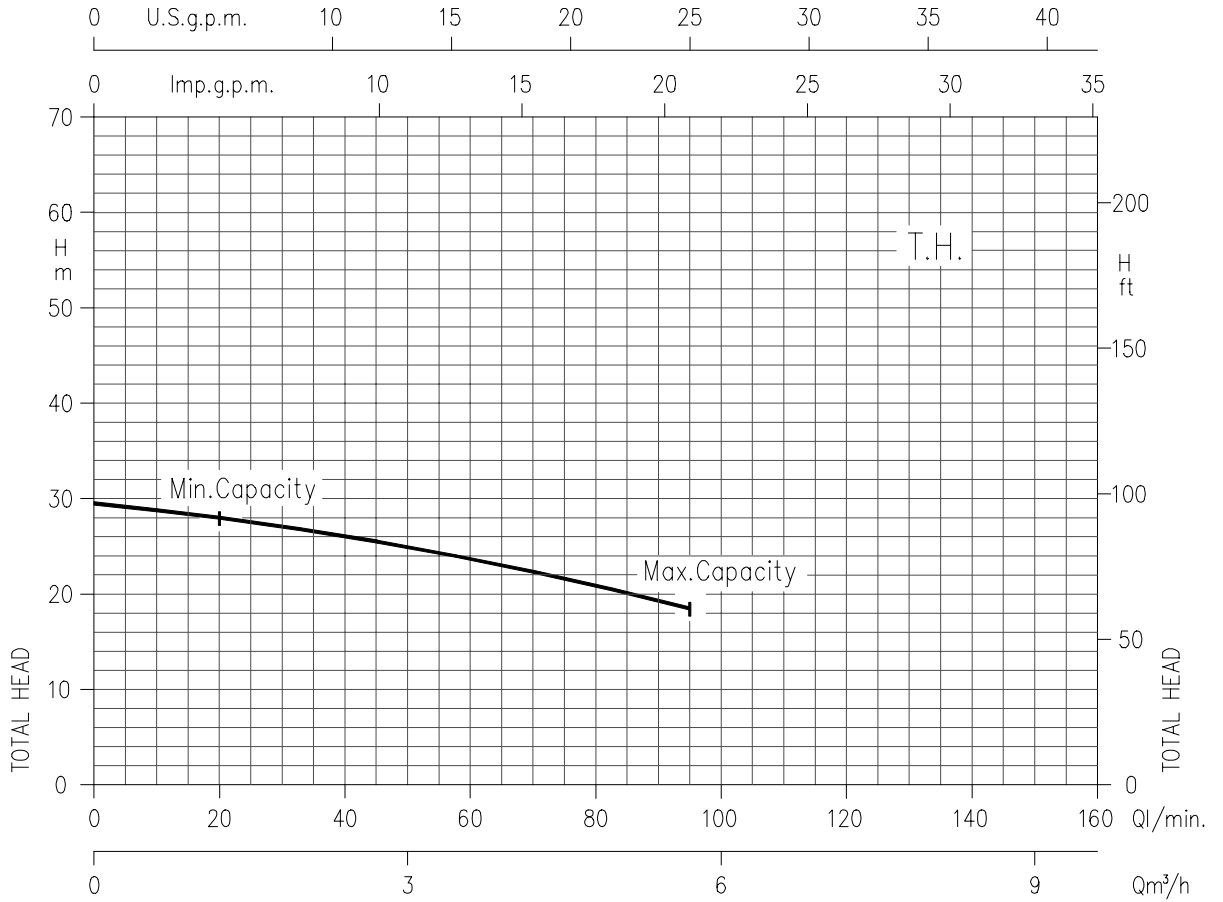

Temperature of water: 20°C
Impeller diameter = 147 mm
Applicable standard of test: ISO 9906-Annex A

CENTRIFUGAL PUMPS

CMA-B-C-D

PERFORMANCE CURVE

50Hz

**CMA 1.00 (0.75 kW)
 SYNCHRONOUS SPEED: 3000 min⁻¹**

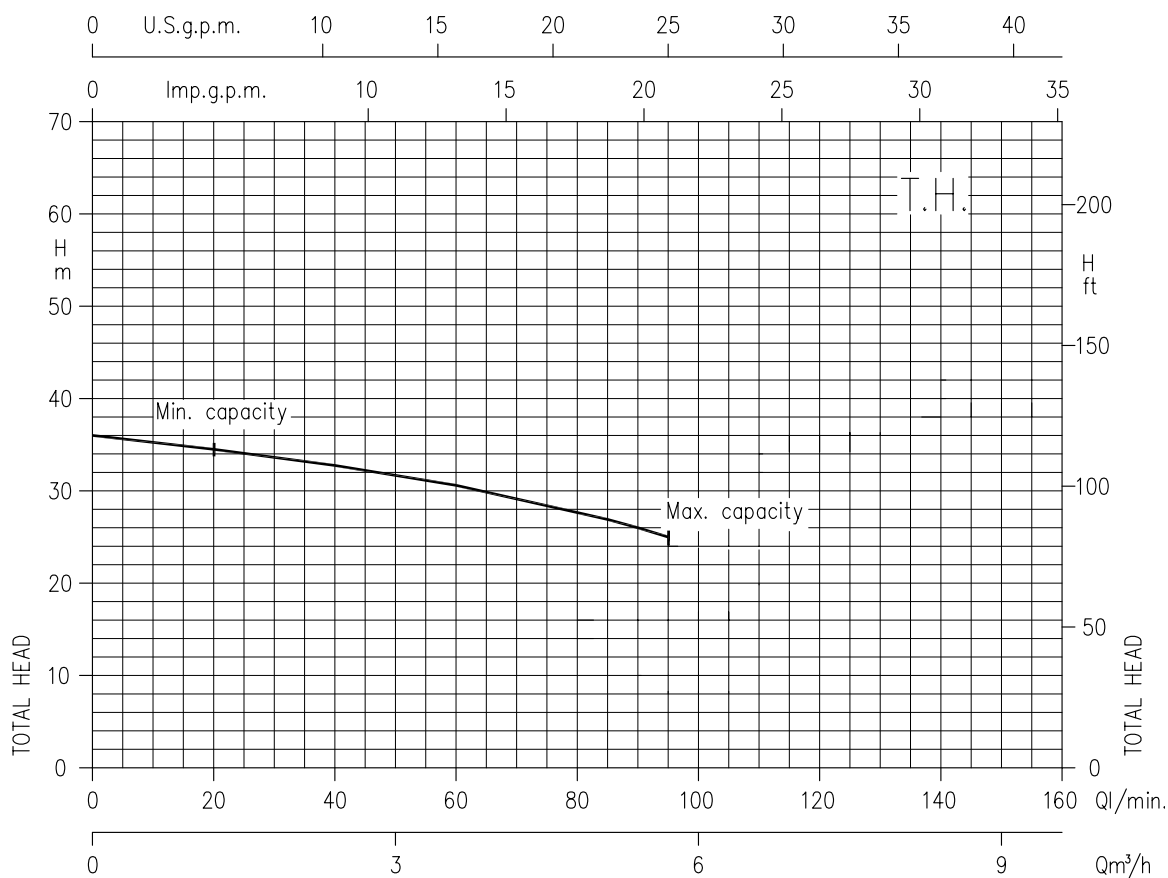

Temperature of water: 20°C
 Impeller diameter = 160 mm
 Applicable standard of test: ISO 9906-Annex A

CENTRIFUGAL PUMPS

CMA-B-C-D

PERFORMANCE CURVE

50Hz

CMA 1.50 (1.1 kW)
SYNCHRONOUS SPEED: 3000 min⁻¹

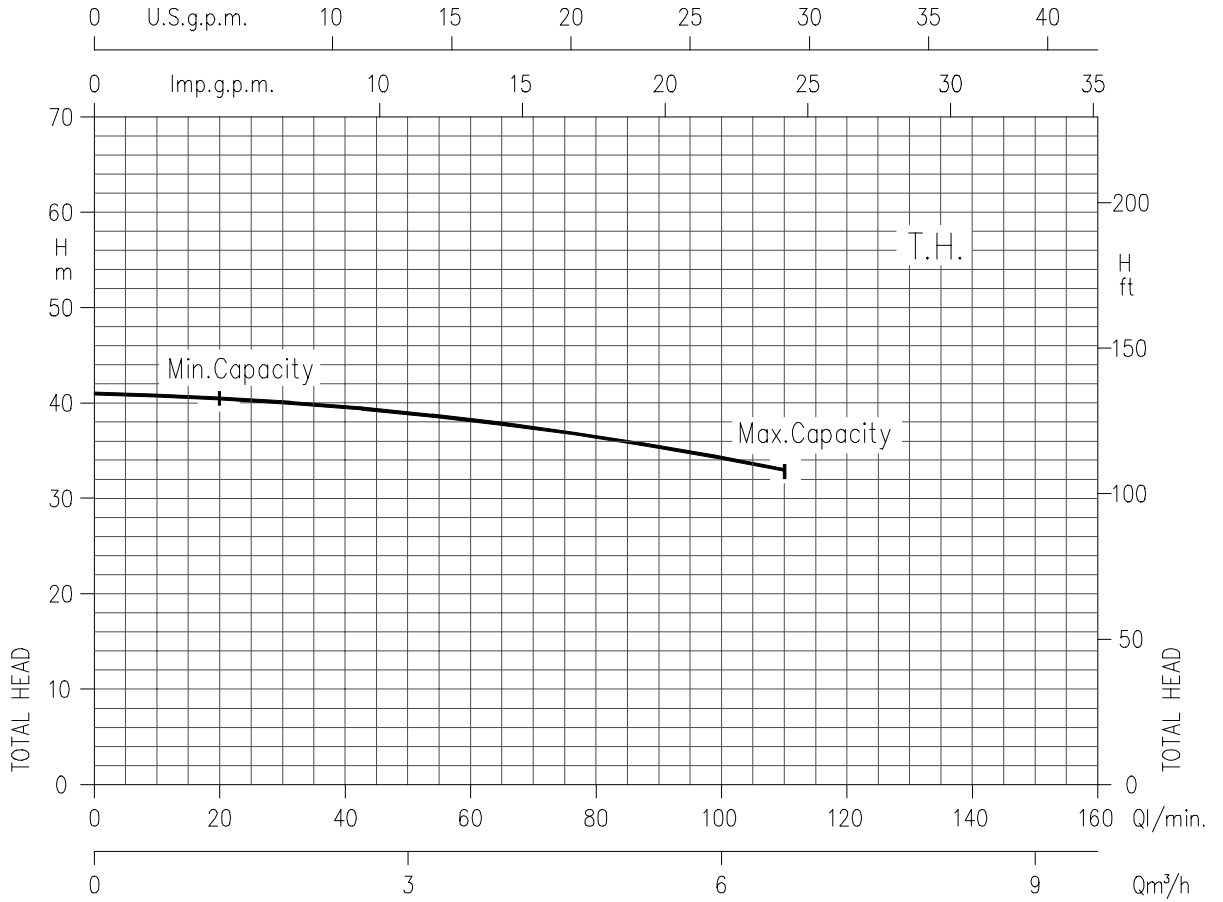

Temperature of water: 20°C
Impeller diameter = 173 mm
Applicable standard of test: ISO 9906-Annex A

CENTRIFUGAL PUMPS

CMA-B-C-D

PERFORMANCE CURVE

50Hz

CMA 2.00 (1.5 kW)
SYNCHRONOUS SPEED: 3000 min⁻¹

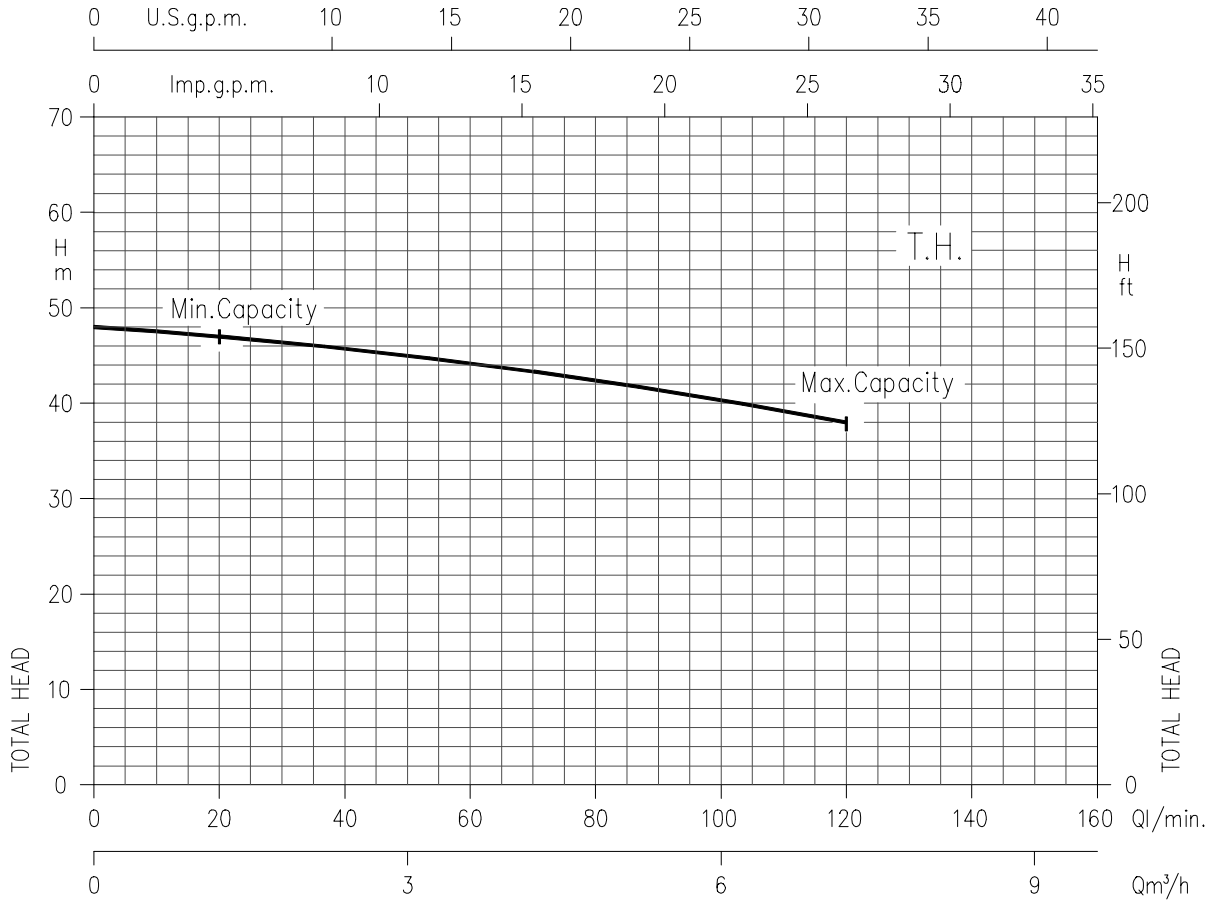

Temperature of water: 20°C
Impeller diameter = 191 mm
Applicable standard of test: ISO 9906-Annex A

CENTRIFUGAL PUMPS

CMA-B-C-D

PERFORMANCE CURVE

50Hz

CMA 3.00 (2.2 kW)
SYNCHRONOUS SPEED: 3000 min⁻¹

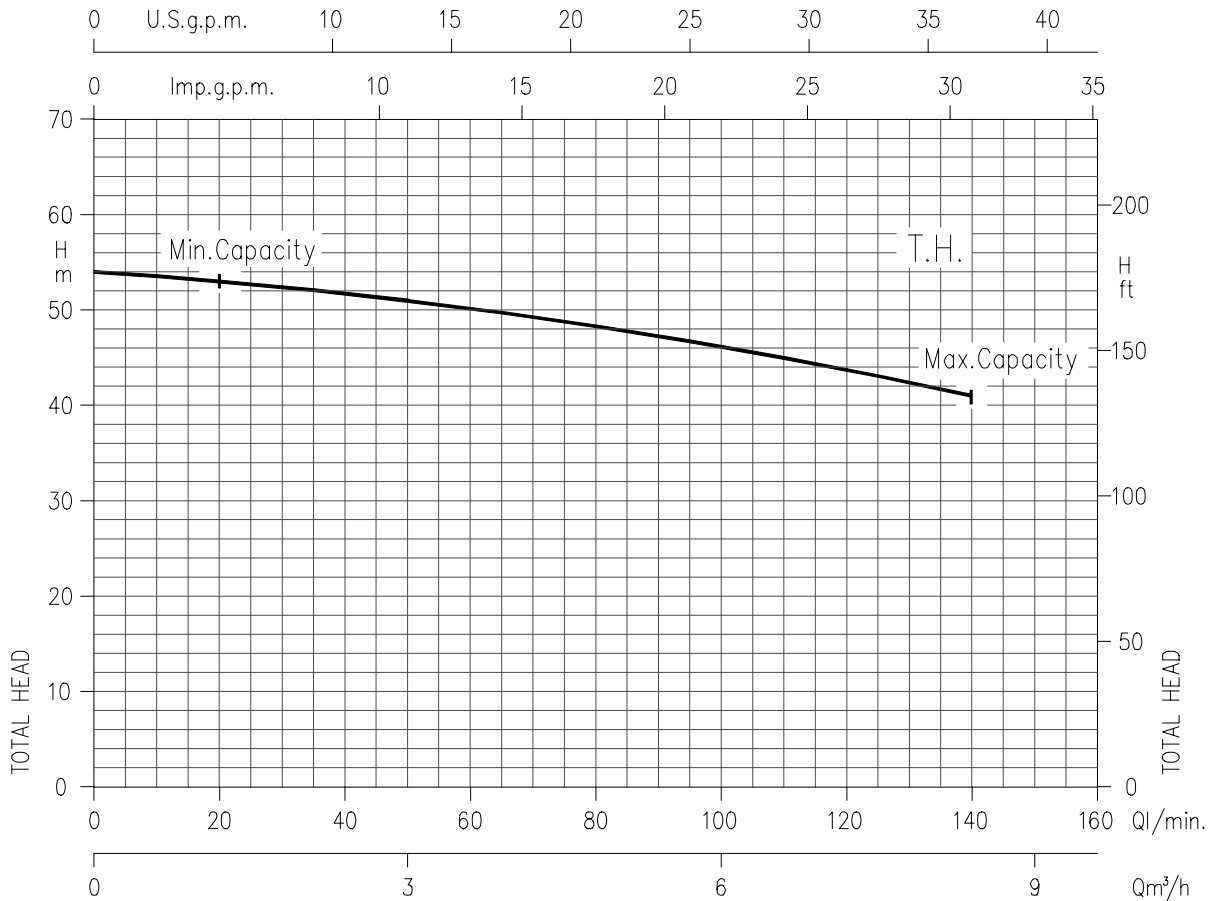

Temperature of water: 20°C
Impeller diameter = 201 mm
Applicable standard of test: ISO 9906-Annex A

CENTRIFUGAL PUMPS

CMA-B-C-D

PERFORMANCE CURVE

50Hz

CMB 0.75 (0.55 kW)
SYNCHRONOUS SPEED: 3000 min⁻¹

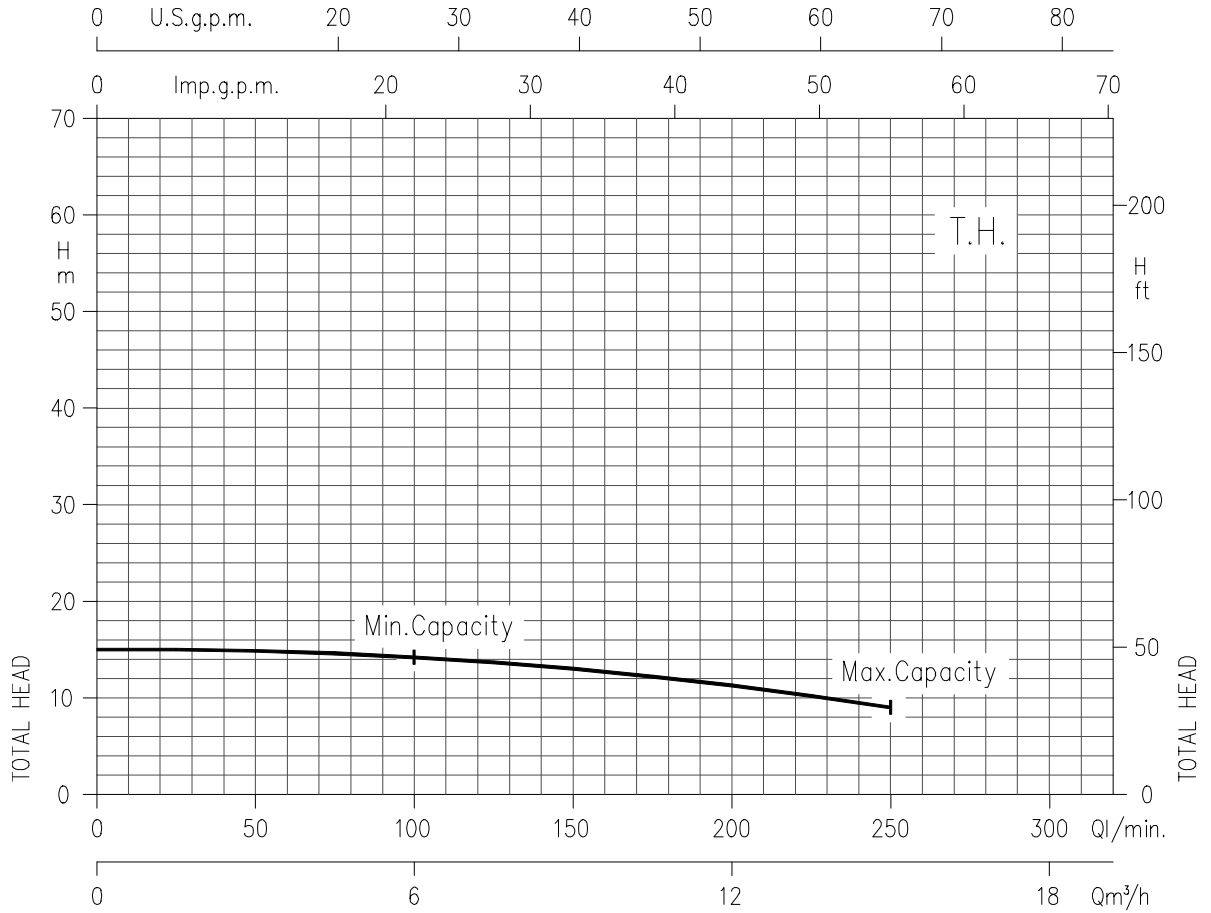

Temperature of water: 20°C
Impeller diameter = 112 mm
Applicable standard of test: ISO 9906-Annex A

CENTRIFUGAL PUMPS

CMA-B-C-D

PERFORMANCE CURVE

50Hz

CMB 1.00 (0.75 kW)
SYNCHRONOUS SPEED: 3000 min⁻¹

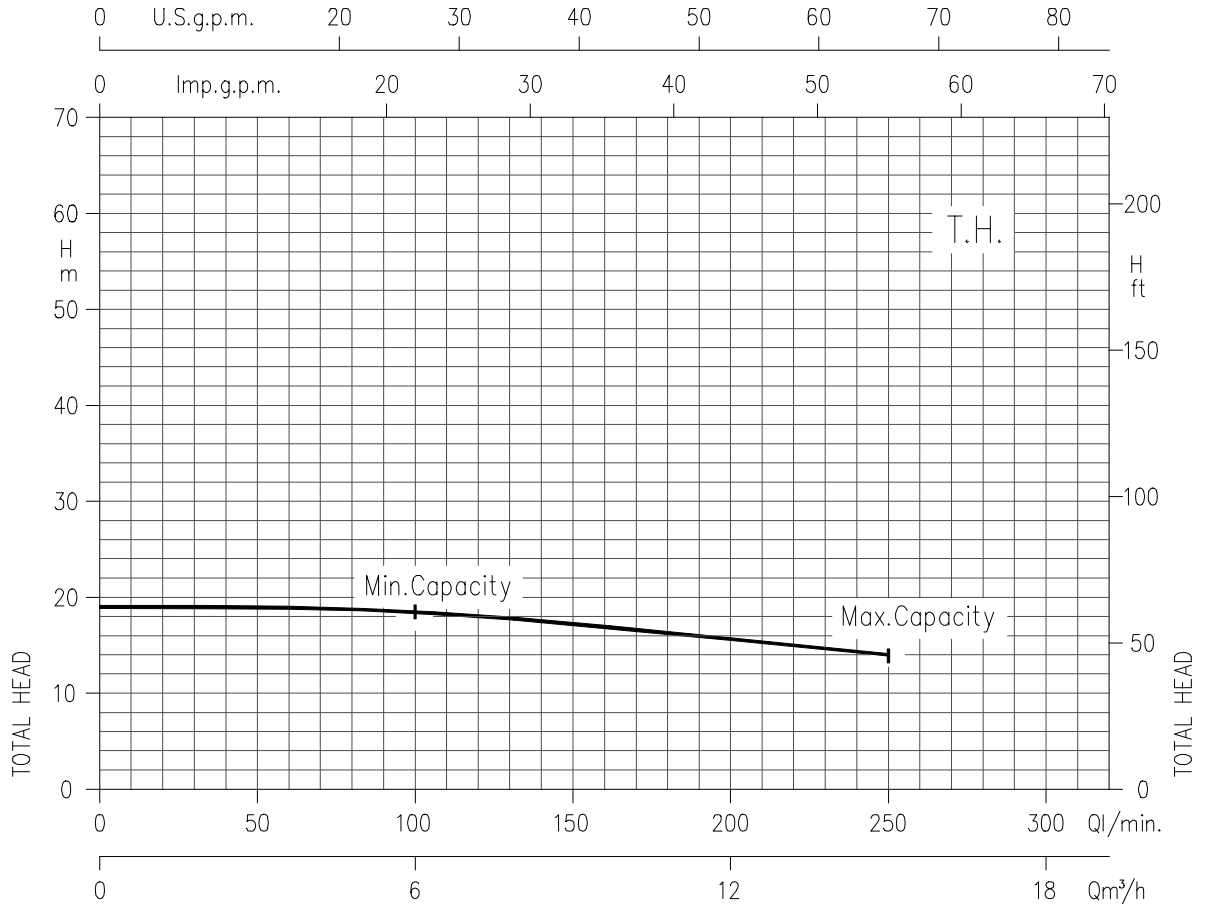

Temperature of water: 20°C
Impeller diameter = 123 mm
Applicable standard of test: ISO 9906-Annex A

CENTRIFUGAL PUMPS

CMA-B-C-D

PERFORMANCE CURVE

50Hz

**CMB 1.50 (1.1 kW)
SYNCHRONOUS SPEED: 3000 min⁻¹**

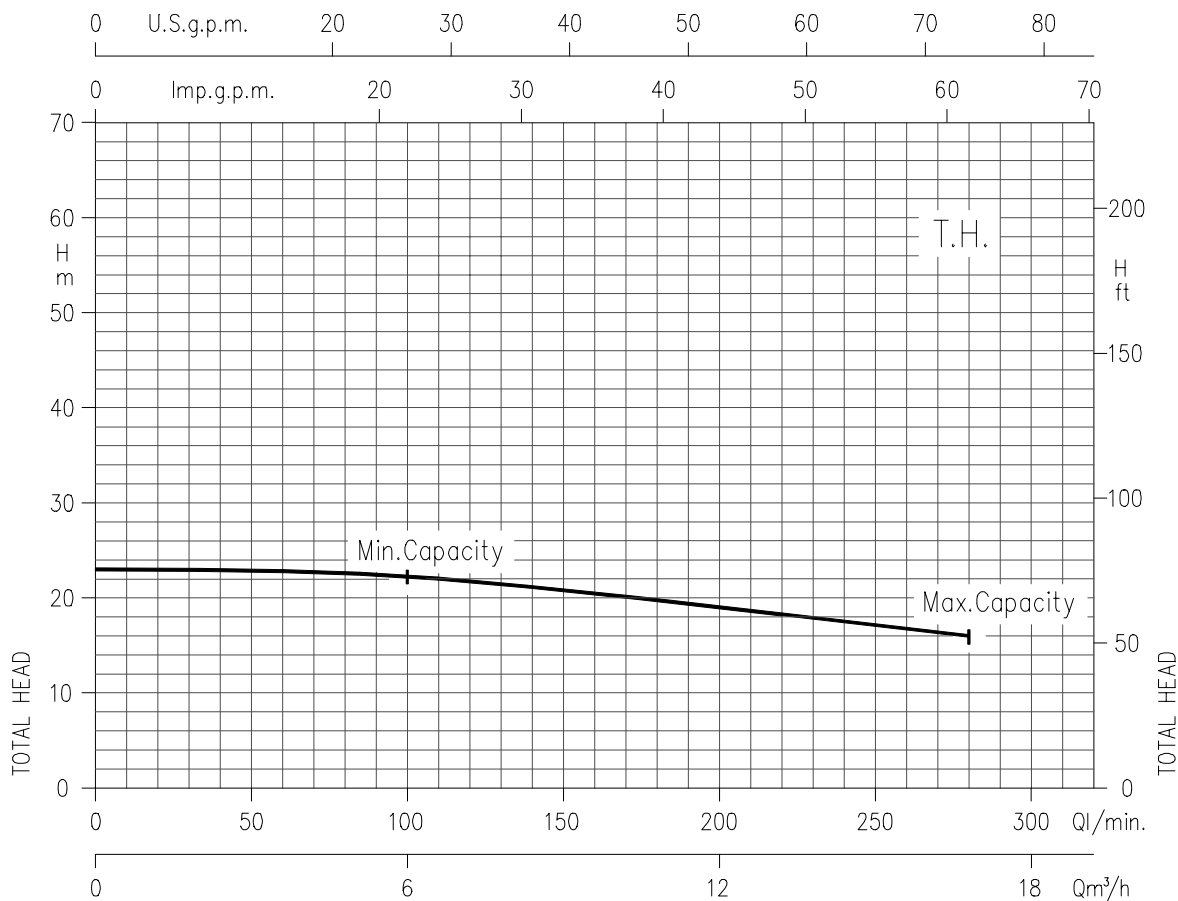

Temperature of water: 20°C
 Impeller diameter = 132 mm
 Applicable standard of test: ISO 9906-Annex A

CENTRIFUGAL PUMPS

CMA-B-C-D

PERFORMANCE CURVE

50Hz

**CMB 2.00 (1.5 kW)
SYNCHRONOUS SPEED: 3000 min⁻¹**

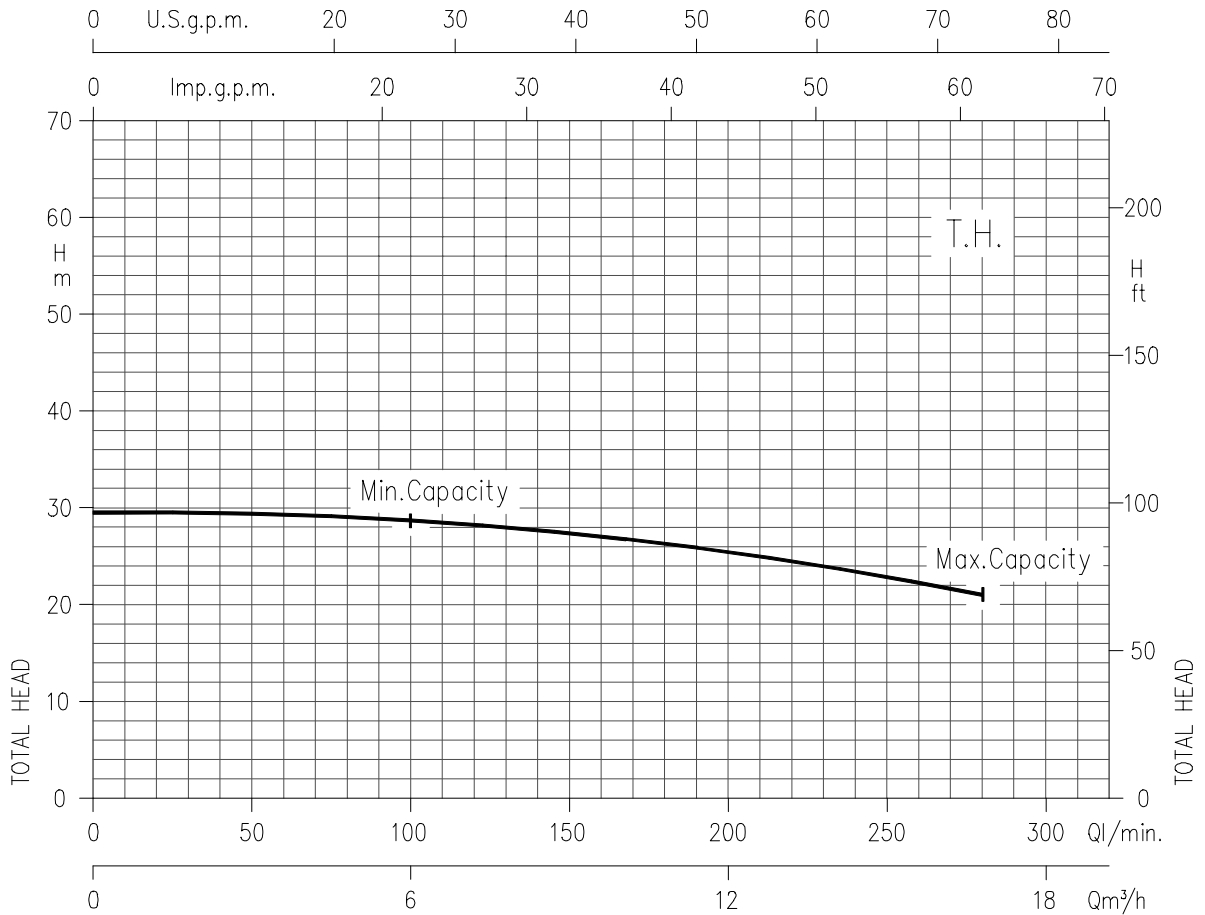

Temperature of water: 20°C
Impeller diameter = 155 mm
Applicable standard of test: ISO 9906-Annex A

CENTRIFUGAL PUMPS

CMA-B-C-D

PERFORMANCE CURVE

50Hz

**CMB 3.00 (2.2 kW)
SYNCHRONOUS SPEED: 3000 min⁻¹**

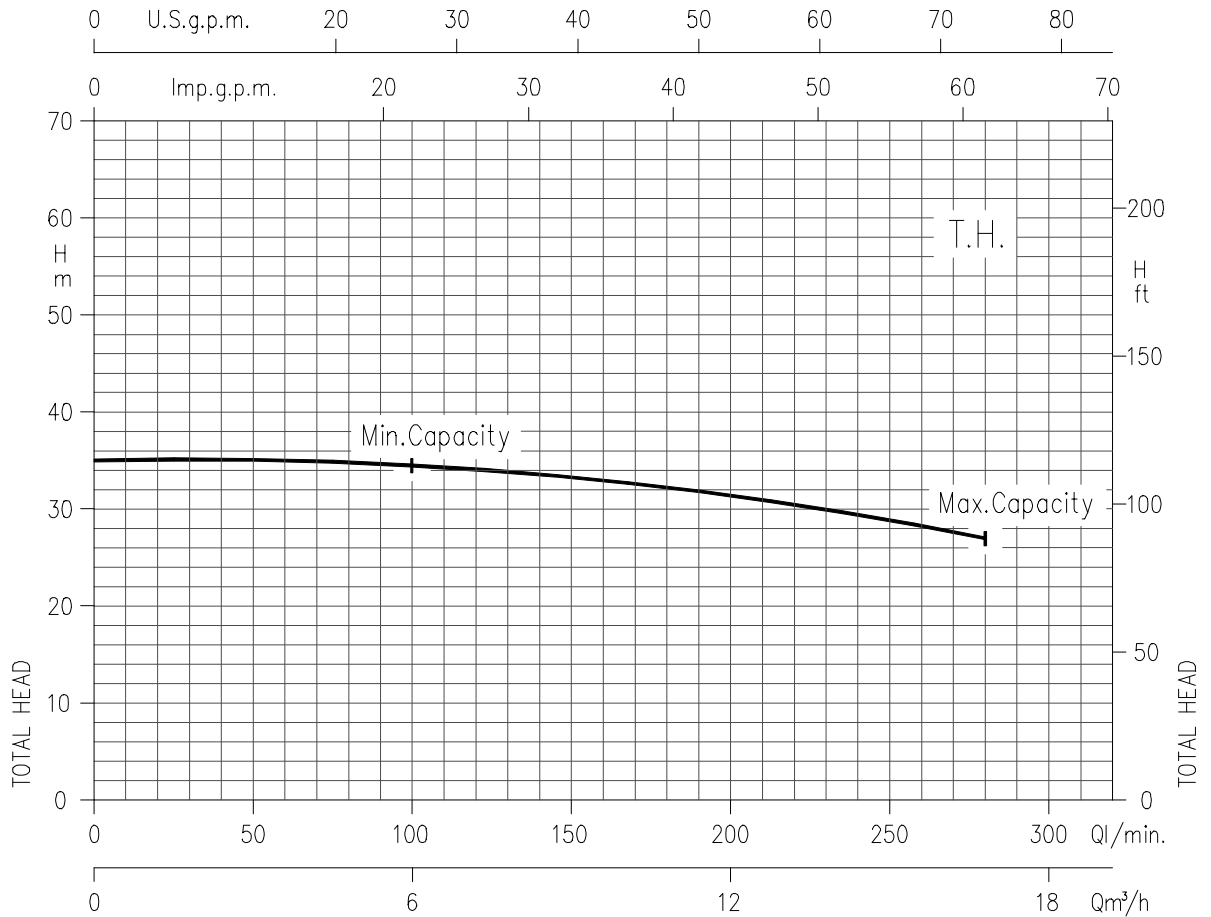

Temperature of water: 20°C
 Impeller diameter = 164.5 mm
 Applicable standard of test: ISO 9906-Annex A

CENTRIFUGAL PUMPS

CMA-B-C-D

PERFORMANCE CURVE

50Hz

**CMB 4.00 (3 kW)
SYNCHRONOUS SPEED: 3000 min⁻¹**

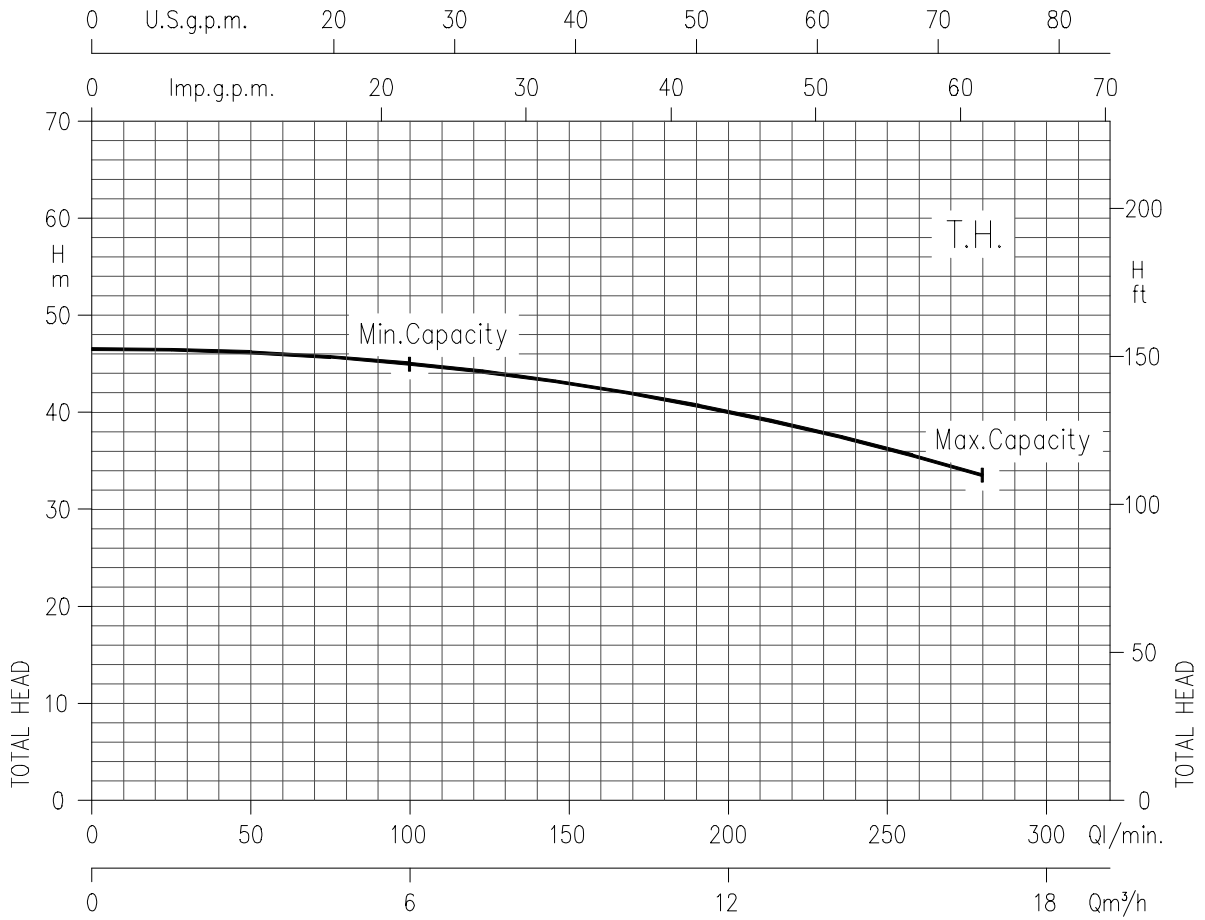

Temperature of water: 20°C
Impeller diameter = 189 mm
Applicable standard of test: ISO 9906-Annex A

CENTRIFUGAL PUMPS

CMA-B-C-D

PERFORMANCE CURVE

50Hz

CMB 5.50 (4 kW)
SYNCHRONOUS SPEED : 3000 min⁻¹

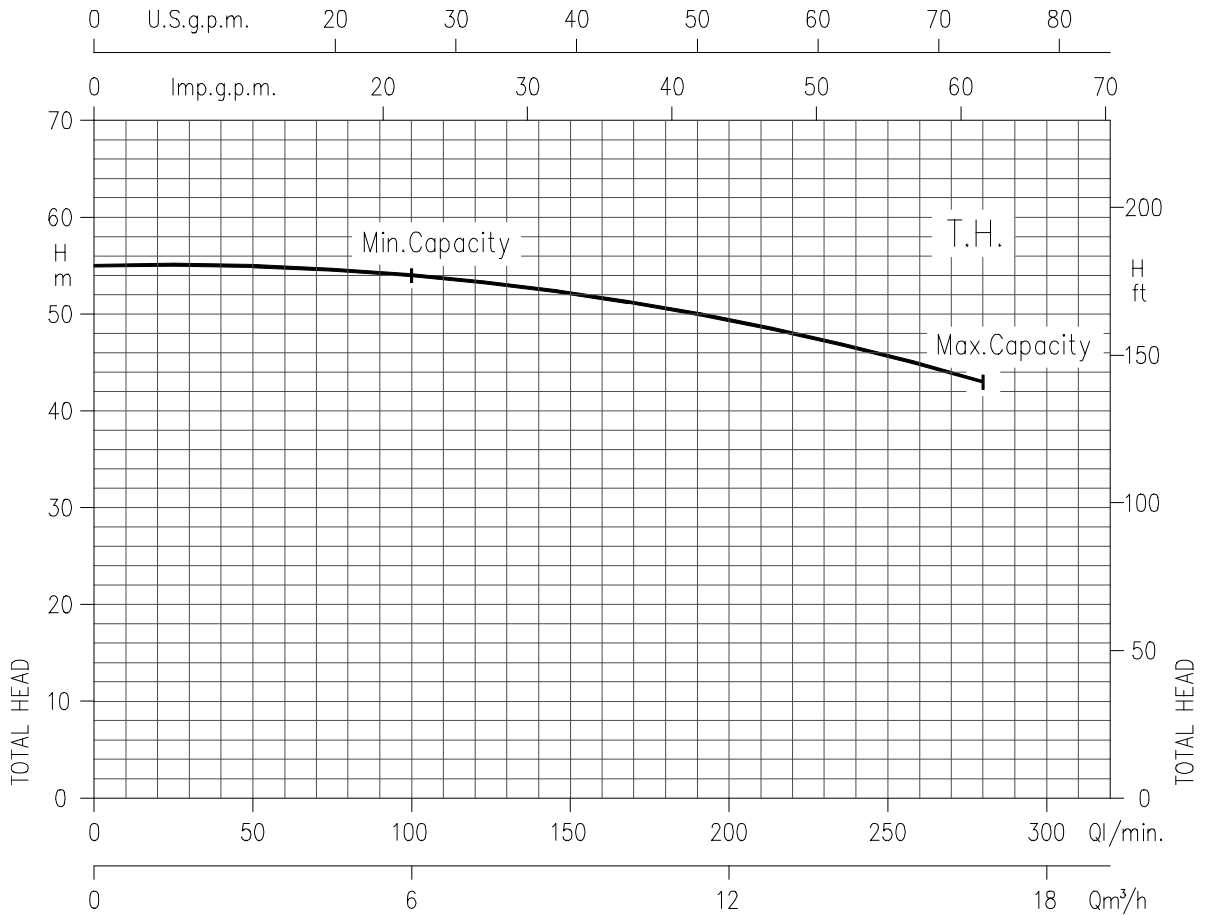

Temperature of water: 20°C
Impeller diameter = 204 mm
Applicable standard of test: ISO 9906-Annex A

CENTRIFUGAL PUMPS

CMA-B-C-D

PERFORMANCE CURVE

50Hz

**CMC 0.75 (0.55 kW)
SYNCHRONOUS SPEED: 3000 min⁻¹**

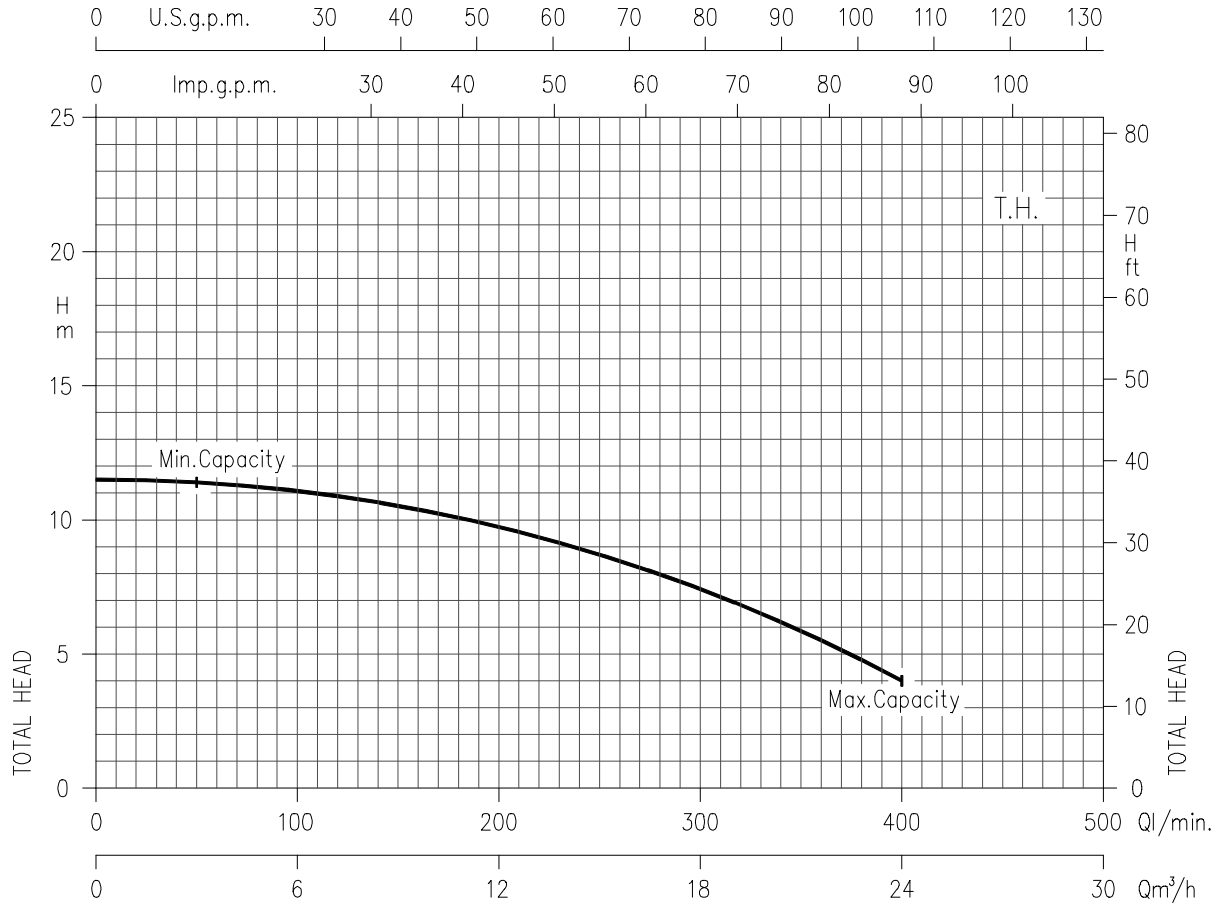

Temperature of water: 20°C
Impeller diameter = 100 mm
Applicable standard of test: ISO 9906-Annex A

CENTRIFUGAL PUMPS

CMA-B-C-D

PERFORMANCE CURVE

50Hz

CMC 1.00 (0.75 kW)
SYNCHRONOUS SPEED: 3000 min⁻¹

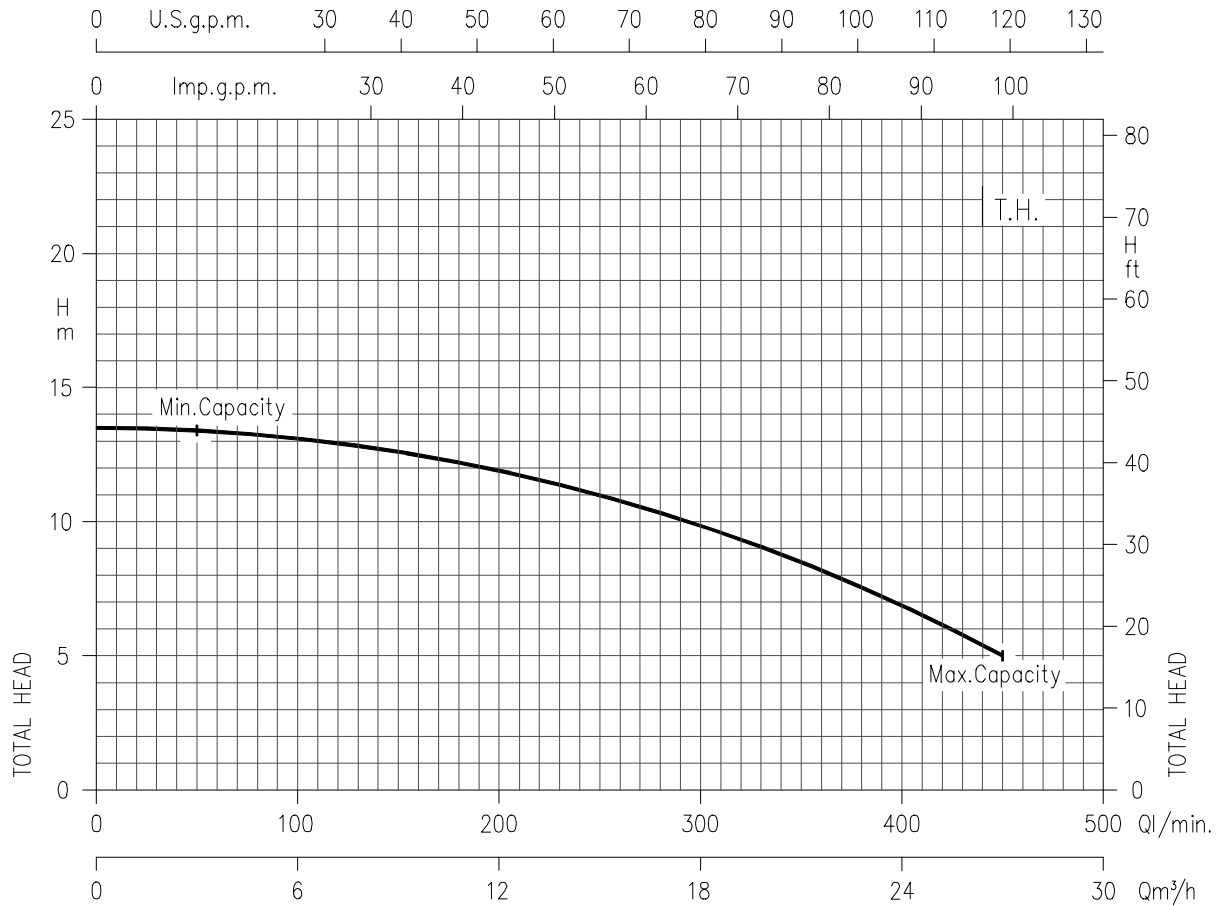

Temperature of water: 20°C
Impeller diameter = 112 mm
Applicable standard of test: ISO 9906-Annex A

CENTRIFUGAL PUMPS

CMA-B-C-D

PERFORMANCE CURVE

50Hz

CMD 1.50 (1.1 kW)
SYNCHRONOUS SPEED: 3000 min⁻¹

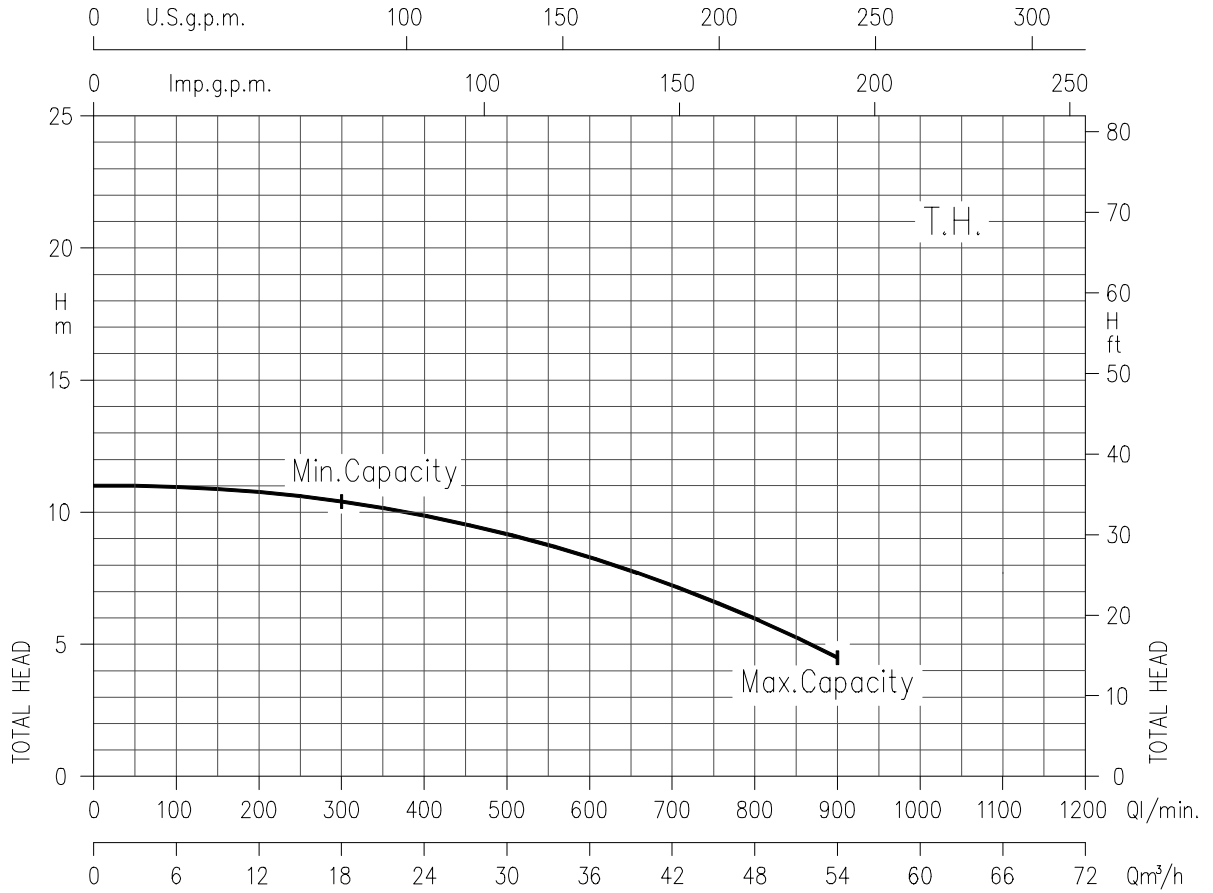

Temperature of water: 20°C
Impeller diameter = 105 mm
Applicable standard of test: ISO 9906-Annex A

CENTRIFUGAL PUMPS

CMA-B-C-D

PERFORMANCE CURVE

50Hz

CMD 2.00 (1.5 kW)
SYNCHRONOUS SPEED: 3000 min⁻¹

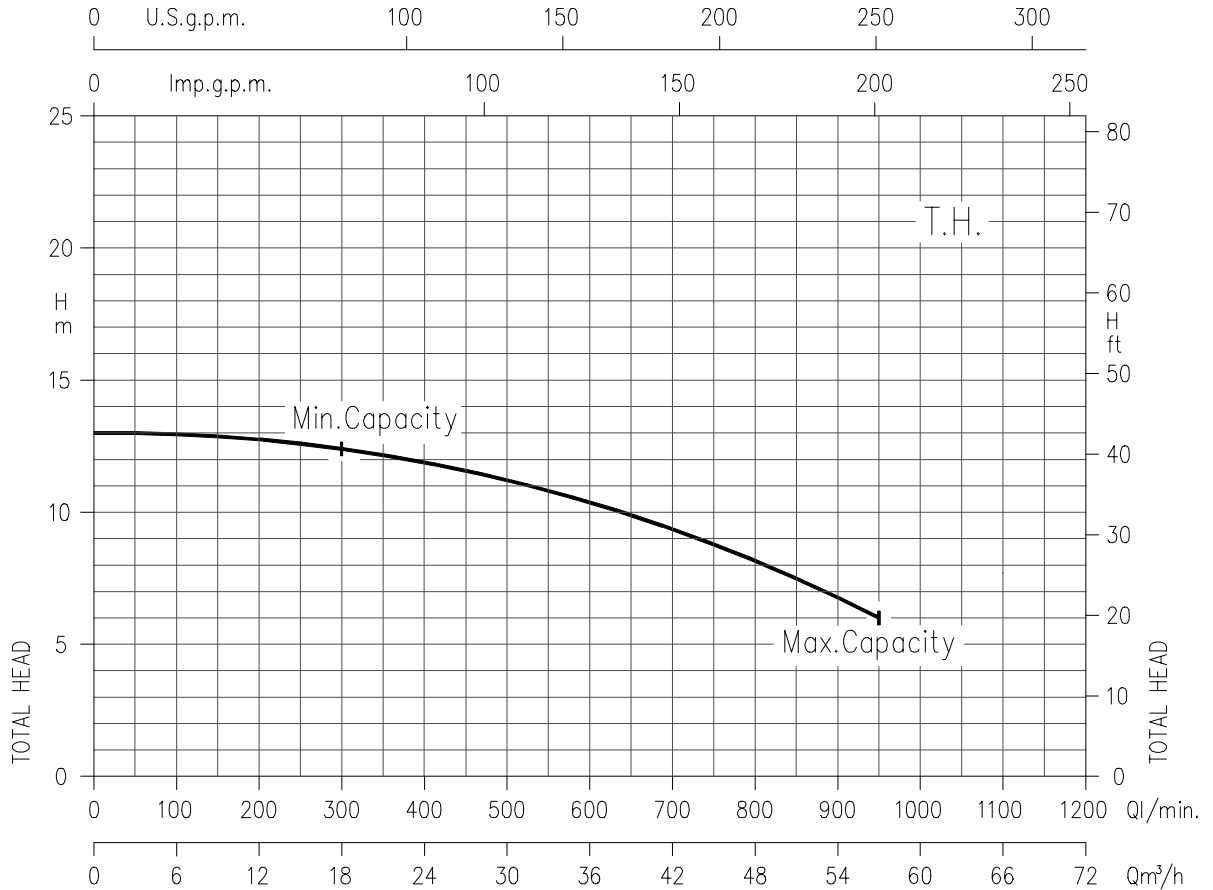

Temperature of water: 20°C
Impeller diameter = 110 mm
Applicable standard of test: ISO 9906-Annex A

CENTRIFUGAL PUMPS

CMA-B-C-D

PERFORMANCE CURVE

50Hz

CMD 3.00 (2.2 kW)
SYNCHRONOUS SPEED: 3000 min⁻¹

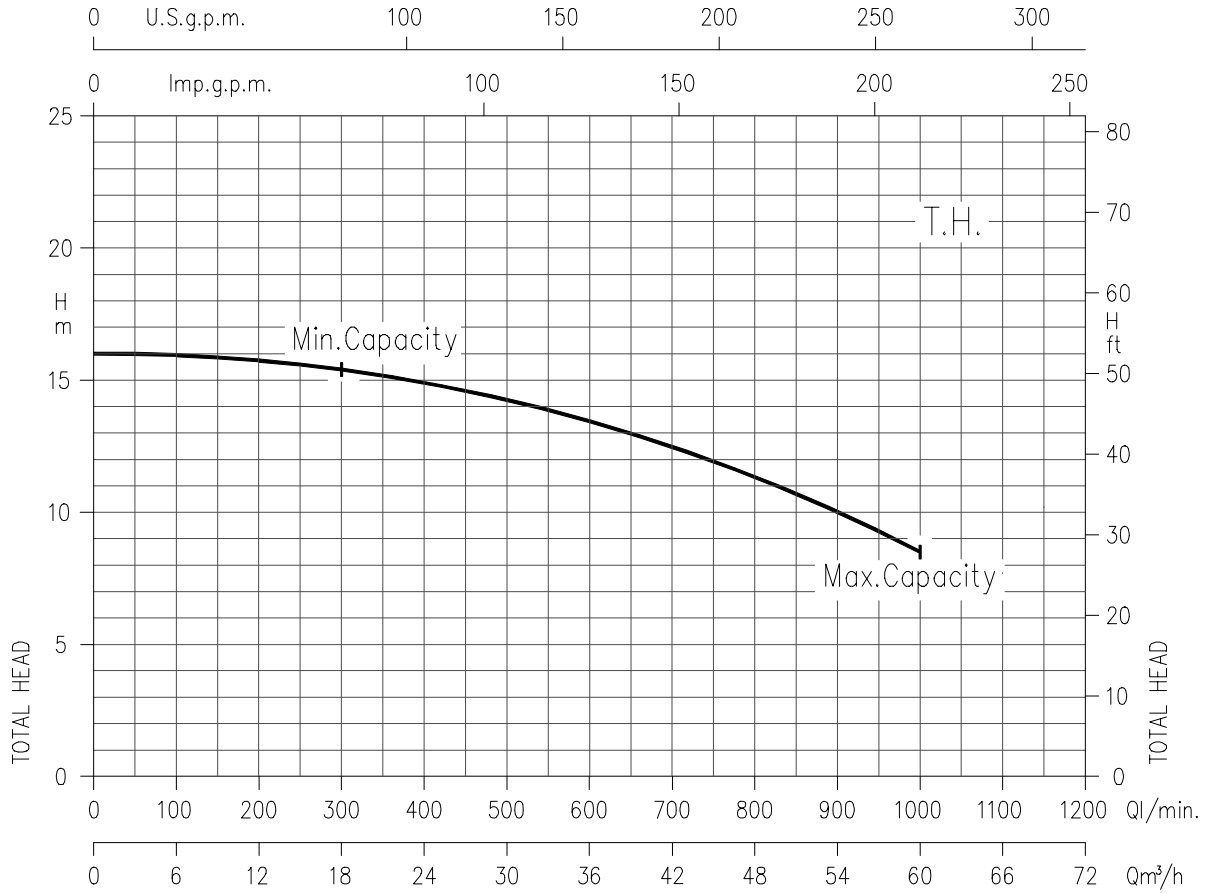

Temperature of water: 20°C
Impeller diameter = 120 mm
Applicable standard of test: ISO 9906-Annex A

CENTRIFUGAL PUMPS

CMA-B-C-D

PERFORMANCE CURVE

50Hz

**CMD 4.00 (3 kW)
SYNCHRONOUS SPEED : 3000 min⁻¹**

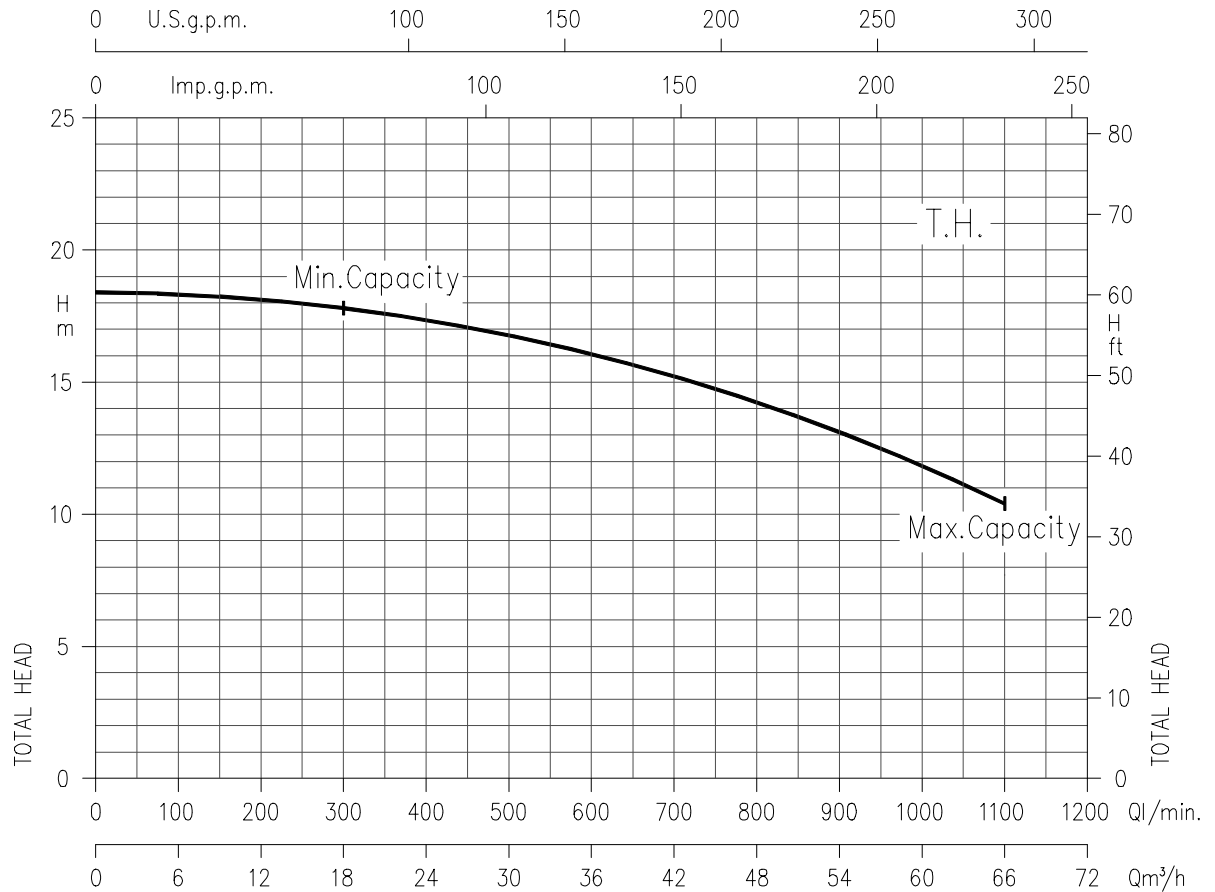

Temperature of water: 20°C
 Impeller diameter = 123 mm
 Applicable standard of test: ISO 9906-Annex A

CENTRIFUGAL PUMPS

CMA-B-C-D

CONSTRUCTIONS

50Hz

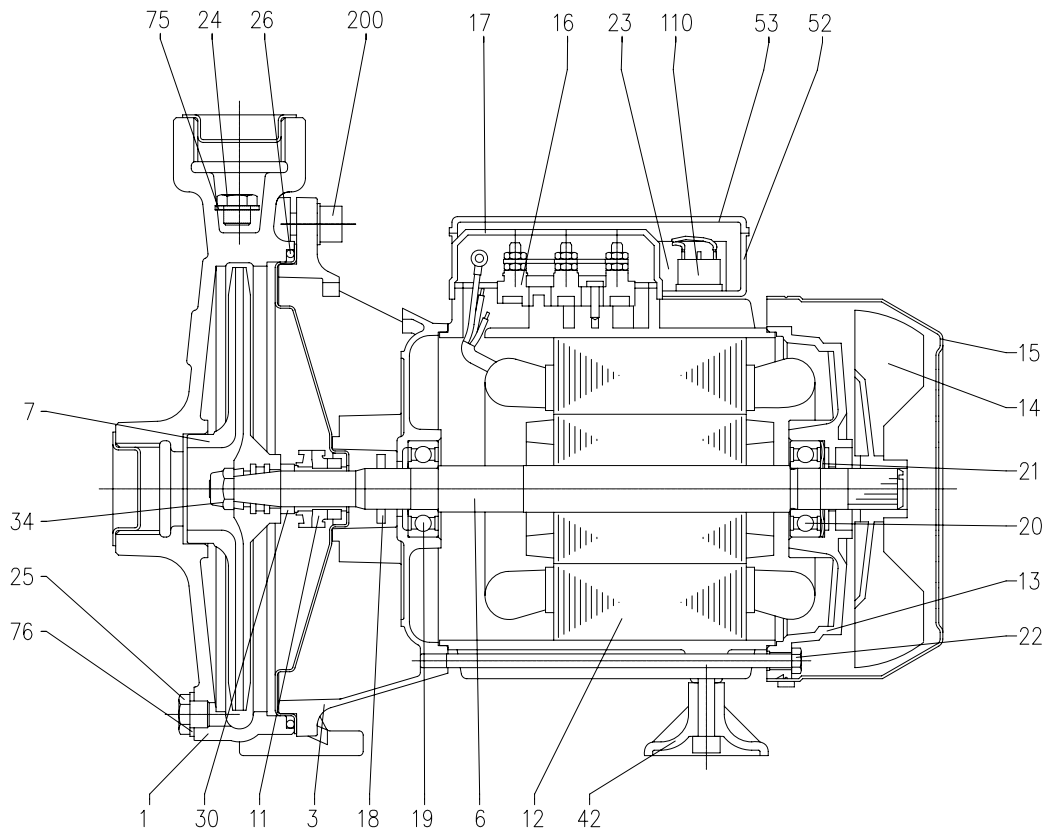
SECTIONAL VIEW
CM series up to 1.00

N°	PART NAME	MATERIAL	Q.TY	N°	PART NAME	MATERIAL	Q.TY
1	Casing	Cast iron	1	21	Adjusting ring	Steel C70	1
3	Motor bracket	Aluminium	1	22	Tie rod	Fe 42 Zinked	4
4	Casing cover	AISI 304	1	23	Capacitor [5]	-	1
6	Shaft with rotor	[1]	1	24	Priming plug	Brass	1
7	Impeller	[2]	1	25	Drain plug	Brass	1
11	Mechanical seal [3]	Carbon/Ceramic/NBR	1	26	O-ring	NBR	1
12	Motor frame with stator	-	1	30	Mechanical seal spacer [6]	Brass	1
13	Motor cover [4]	Aluminium	1	34	Impeller nut [7]	AISI 304	1
14	Fan	PA6	1	42	Foot	PVC	1
15	Fan cover	Fe P04 Zinked	1	52	Capacitor box [5]	ABS	1
16	Terminal box	-	1	53	Capacitor box cover [5]	ABS	1
17	Terminal box cover [4]	Aluminium	1	75	Washer	Aluminium	1
18	Splash ring	NBR	1	76	Washer	Aluminium	1
19	Pump side ball bearing	-	1	200	Screw	Stainless steel A2 UNI7323	4
20	Fan side ball bearing	-	1	-	-	-	-

[1] Material: AISI 416 (integral) for CMA 0.50
AISI 420 for other model;

[7] Except for CMA 0.50

[2] Material: PPO mod. glass fibre reinforced for version CMA
Cast iron for version CMB, CMC;

[3] See constructions mechanical seal page 302-303

[4] Only for three phase

[5] Only for single phase

[6] Only for version: CMA 0.50, CMB 0.75-1.00, CMC 0.75-1.00

300

CENTRIFUGAL PUMPS

CMA-B-C-D

CONSTRUCTIONS

50Hz

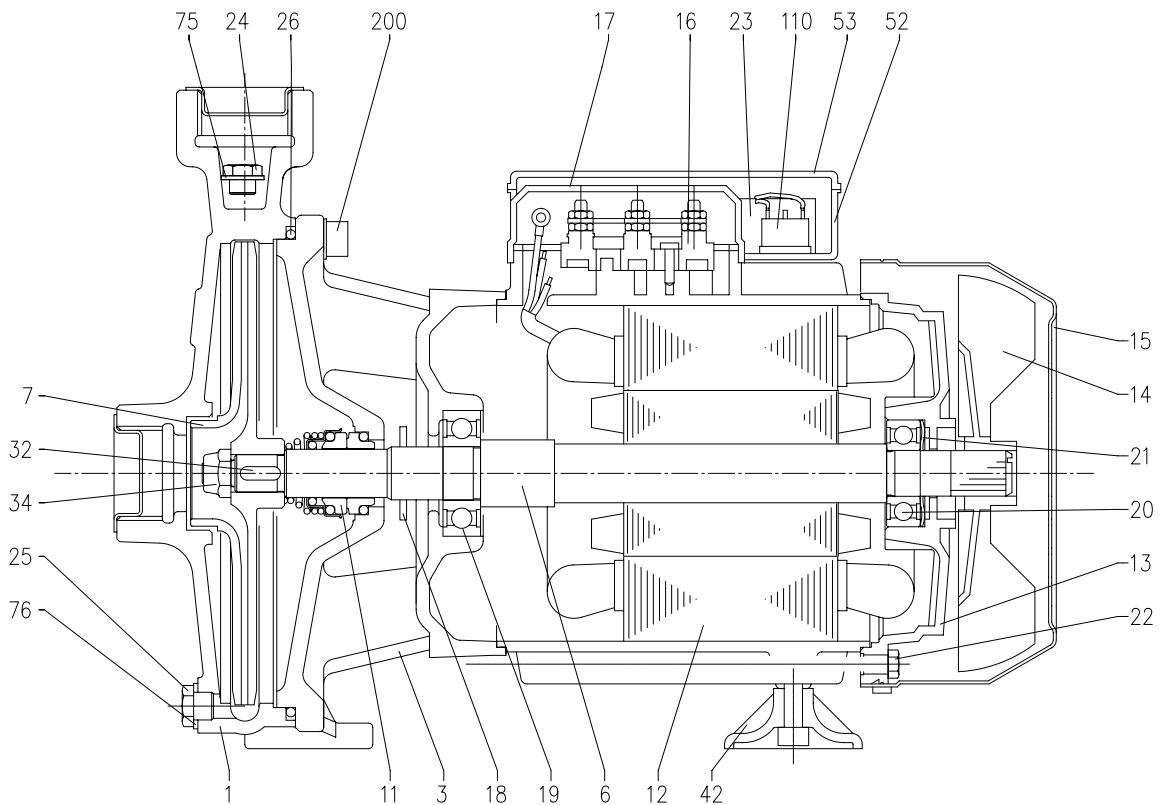
SECTIONAL VIEW
CM series 1.50 and over

N°	PART NAME	MATERIAL	Q.TY	N°	PART NAME	MATERIAL	Q.TY
1	Casing	Cast iron	1	22	Tie rod	Fe 42 Zinked	4
3	Motor bracket	Cast iron	1	23	Capacitor [4]	-	1
6	Shaft with rotor	[1]	1	24	Priming plug	Brass	1
7	Impeller	[2]	1	25	Drain plug	Brass	1
11	Mechanical seal [3]	Carbon/Ceramic/NBR	1	26	O-ring	NBR	1
12	Motor frame with stator	-	1	32	Key	AISI 304	1
13	Motor cover [4]	Aluminium	1	34	Impeller nut	AISI 304	1
14	Fan	PA6	1	42	Foot	PVC	1
15	Fan cover	Fe P04 Zinked	1	52	Capacitor box [5]	ABS	1
16	Terminal board	-	1	53	Capacitor box cover [5]	ABS	
17	Terminal box cover [4]	Aluminium	1	75	Washer	Aluminium	1
18	Splash ring	NBR	1	76	Washer	Aluminium	1
19	Pump side ball bearing	-	1	101	Seeger ring	AISI 420	1
20	Fan side ball bearing	-	1	110	Protector	-	1
21	Adjusting ring	Steel C70	1	200	Screw	Stainless steel A2 UNI7323	4

[1] Wet extension: AISI303 for version CMA, CMB 1.50-2.00-3.00, CMD 1.50-2.00-3.00
AISI304 for version CMB 4.00-5.50, CMD 4.00

[2] Brass for version: CMA, CMB 2.00-3.00-4.00-5.50
Cast iron for version: CMB 1.50, CMD

[3] See constructions mechanical seal page 302-303

[4] Only for three phase

[5] Only for single phase

**MECHANICAL SEAL
CM series up to 1.00**

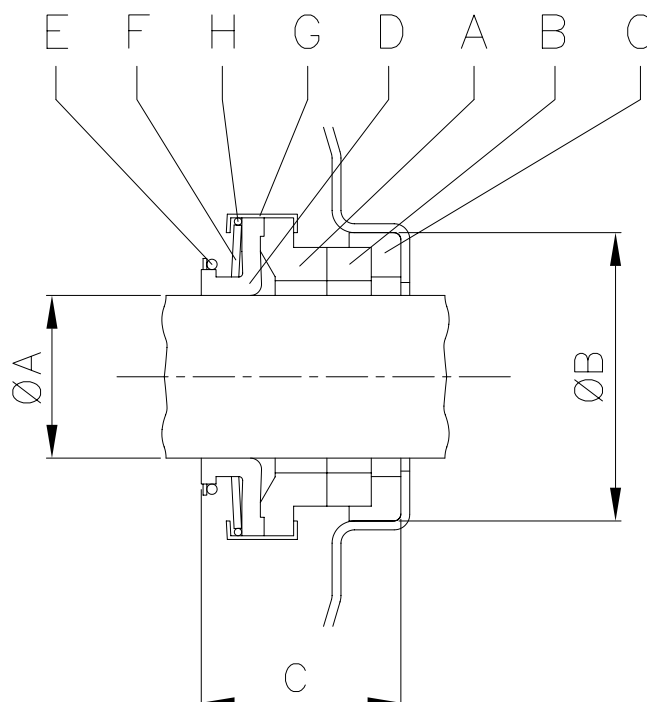

Pump type		Dimensions mm		
Single phase	Three phase	Ø A	Ø B	C
CMA 0.50 M	CMA 0.50 T	12	26	18.3
CMA 0.75 M	CMA 0.75 T	13	26	18.3
CMA 0.80 M	CMA 0.80 T	13	26	18.3
CMA 1.00 M	CMA 1.00 T	13	26	18.3
CMB 0.75 M	CMB 0.75 T	13	26	18.3
CMB 1.00 M	CMB 1.00 T	13	26	18.3
CMC 0.75 M	CMC 0.75 T	13	26	18.3
CMC 1.00 M	CMC 1.00 T	13	26	18.3

REF	PART NAME	MATERIAL product standard
A	Rotary seal ring	carbon graphite
B	Stationary seal ring	ceramic
C	Gasket	NBR
D	Bellows	NBR
E	Ring	AISI 304
F	Self driving spring	AISI 304
G	Frame	AISI 304
H	Retainer ring	AISI 304

MECHANICAL SEAL
CM series 1.50 and over

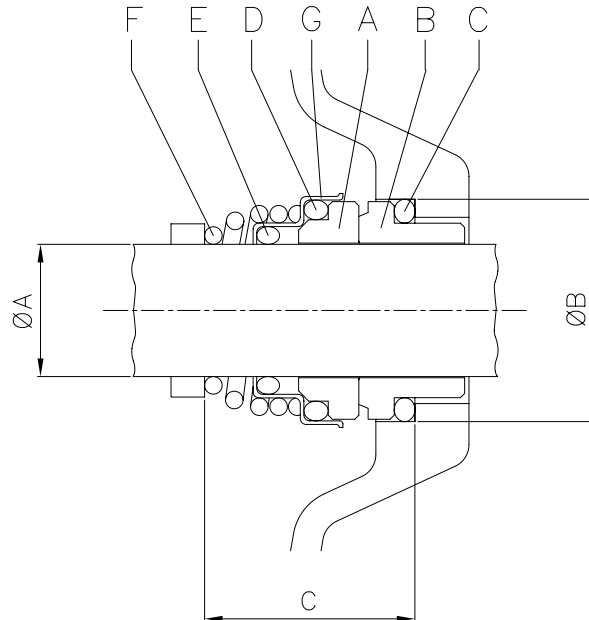

Pump type		Dimensions mm		
Single phase	Three phase	Ø A	Ø B	C
CMA 1.50 M	CMA 1.50 T	18	30.9	32
CMA 2.00 M	CMA 2.00 T	18	30.9	32
-	CMA 3.00 T	18	30.9	32
CMB 1.50 M	CMB 1.50 T	18	30.9	32
CMB 2.00 M	CMB 2.00 T	18	30.9	32
-	CMB 3.00 T	18	30.9	32
-	CMB 4.00 T	20	30.9	33
-	CMB 5.50 T	20	30.9	33
CMD 1.50 M	CMD 1.50 T	18	30.9	32
CMD 2.00 M	CMD 2.00 T	18	30.9	32
-	CMD 3.00 T	18	30.9	32
-	CMD 4.00 T	18	30.9	32

REF	PART NAME	MATERIAL product standard
A	Rotary seal ring	ceramic
B	Stationary seal ring	carbon graphite
C	O Ring	NBR
D	O Ring	NBR
E	O Ring	NBR
F	Self driving spring	AISI 316
G	Frame	AISI 304

DIAGRAM AND ELECTRIC CONNECTIONS

THREE PHASE MOTOR

STAR CONNECTION

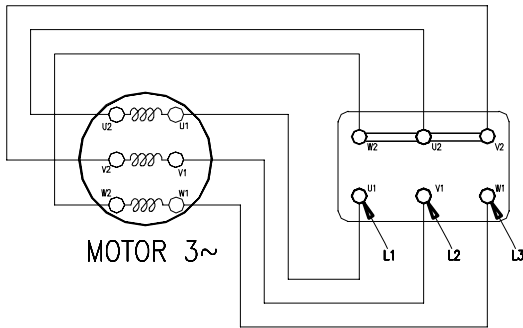

DELTA CONNECTION

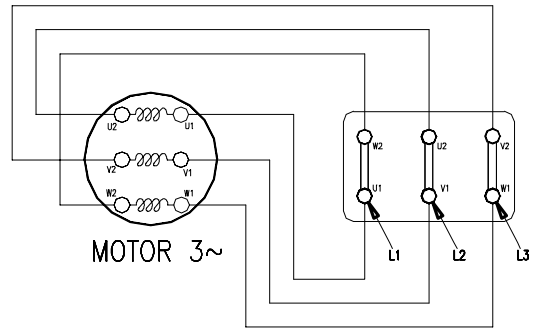

FOR MOTOR 4 kW AND BELOW

DELTA CONNECTION 230 V

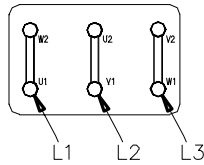

STAR CONNECTION 400 V

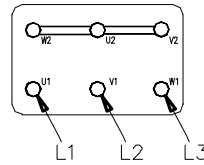
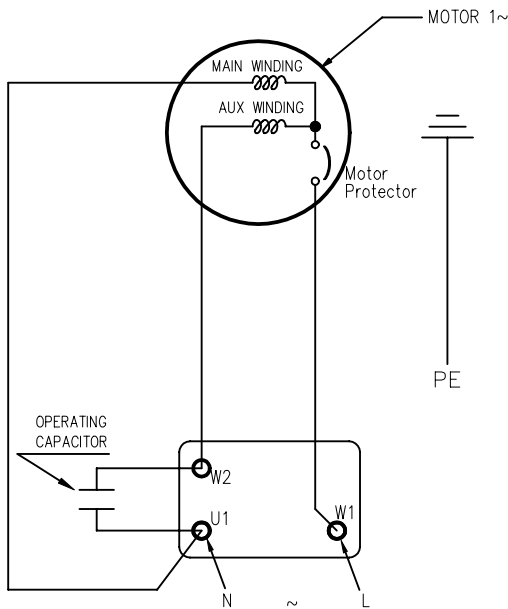

DIAGRAM AND ELECTRIC CONNECTIONS

SINGLE PHASE MOTOR

FOR MOTORS WITH LOCKED ROTOR CURRENT
UP TO 25 [A]
INTERNAL MOTORPROTECTOR

FOR MOTORS WITH LOCKED ROTOR CURRENT
OVER 25 [A]
EXTERNAL MOTORPROTECTOR



Models up to 1.00

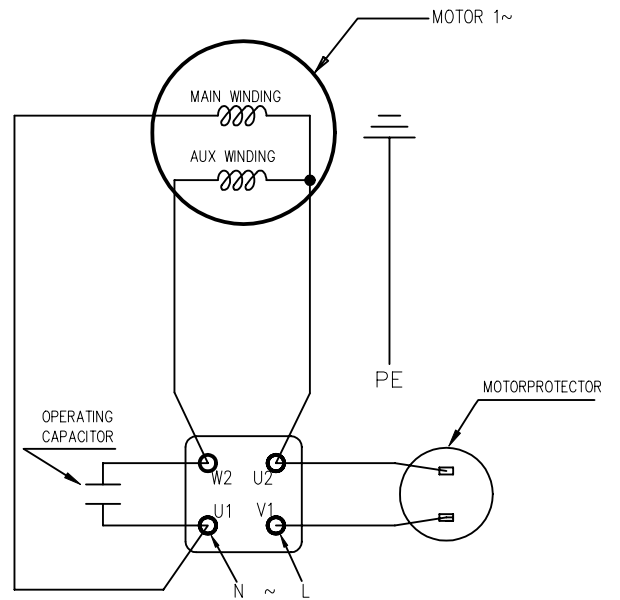

Model 1.50 and over

CENTRIFUGAL PUMPS

CMA-B-C-D

DIMENSIONS

50Hz

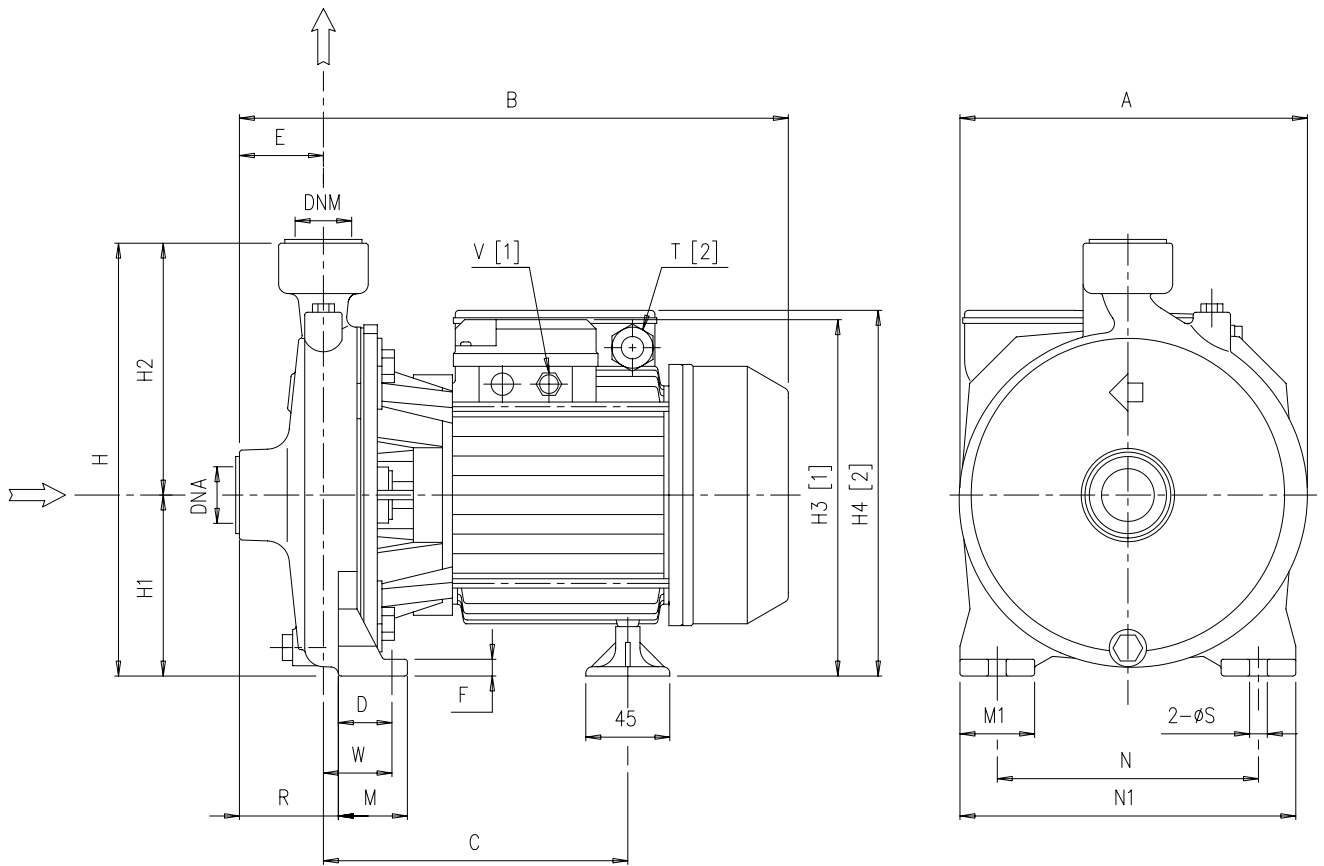

[1] Only for three phase
[2] Only for single phase

CENTRIFUGAL PUMPS

CMA-B-C-D

DIMENSIONS

50 Hz

Pump type	Dimensions [mm]																					
	A	B	C	D	E	F	H	H1	H2	H3	H4	M	M1	N	N1	R	T	V	W	S	DNA	DNM
CMA 0.50M	160	261.8	158.8	30	44	8	202	82	120	-	173	40	40	110	150	44	PG11	-	30	9.5	G 1	G 1
CMA 0.50T	160	261.8	158.8	30	44	8	202	82	120	172.5	-	40	40	110	150	44	-	PG11	30	9.5	G 1	G 1
CMA 0.75M	185	300.3	171.8	36.8	45	9	232	97	135	-	198	45	40	140	180	45	PG11	-	36.8	9.5	G 1	G 1
CMA 0.75T	185	300.3	171.8	36.8	45	9	232	97	135	197.5	-	45	40	140	180	45	-	PG11	36.8	9.5	G 1	G 1
CMA 0.80M	185	300.3	171.8	36.8	45	9	232	97	135	-	198	45	40	140	180	45	PG11	-	36.8	9.5	G 1	G 1
CMA 0.80T	185	300.3	171.8	36.8	45	9	232	97	135	197.5	-	45	40	140	180	45	-	PG11	36.8	9.5	G 1	G 1
CMA 1.00M	185	300.3	171.8	36.8	45	9	232	97	135	-	198	45	40	140	180	45	PG11	-	36.8	9.5	G 1	G 1
CMA 1.00T	185	300.3	171.8	36.8	45	9	232	97	135	197.5	-	45	40	140	180	45	-	PG11	36.8	9.5	G 1	G 1
CMA 1.50M	200	347.3	208.3	41.8	45.5	9	252	100	152	-	232	50	40	155	194	45.5	PG13.5	-	41.8	9.5	G 1 ¼	G 1
CMA 1.50T	200	347.3	208.3	41.8	45.5	9	252	100	152	214	-	50	40	155	194	45.5	-	PG11	41.8	9.5	G 1 ¼	G 1
CMA 2.00M	225	360.3	208.3	41.8	45.5	9	285	115	170	-	247	50	40	180	220	45.5	PG13.5	-	41.8	9.5	G 1 ¼	G 1
CMA 2.00T	225	347.3	208.3	41.8	45.5	9	285	115	170	229	-	50	40	180	220	45.5	-	PG11	41.8	9.5	G 1 ¼	G 1
CMA 3.00T	225	360.3	208.3	41.8	45.5	9	285	115	170	229	-	50	40	180	220	45.5	-	PG11	41.8	9.5	G 1 ¼	G 1
CMB 0.75M	188	315.3	182.3	36.8	49.5	9	251.5	101.5	150	-	127.5	45	40	140	180	65.5	PG11	-	52.8	9.5	G 2	G 1 ¼
CMB 0.75T	188	315.3	182.3	36.8	49.5	9	251.5	101.5	150	127	-	45	40	140	180	65.5	-	PG11	52.8	9.5	G 2	G 1 ¼
CMB 1.00M	188	315.3	182.3	36.8	49.5	9	251.5	101.5	150	-	127.5	45	40	140	180	65.5	PG11	-	52.8	9.5	G 2	G 1 ¼
CMB 1.00T	188	315.3	182.3	36.8	49.5	9	251.5	101.5	150	127	-	45	40	140	180	65.5	-	PG11	52.8	9.5	G 2	G 1 ¼
CMB 1.50M	188	349.3	206.3	36.8	49.5	9	251.5	101.5	150	-	233.5	45	40	140	180	65.5	PG13.5	-	52.8	9.5	G 2	G 1 ¼
CMB 1.50T	188	349.3	206.3	36.8	49.5	9	251.5	101.5	150	215.5	-	45	40	140	180	65.5	-	PG11	52.8	9.5	G 2	G 1 ¼
CMB 2.00M	200	373.3	209.3	36.8	57.5	9	271.5	111.5	160	-	243.5	45	40	160	200	76.5	PG13.5	-	55.8	9.5	G 2	G 1 ¼
CMB 2.00T	200	360.3	209.3	36.8	57.5	9	271.5	111.5	160	225.5	-	45	40	160	200	76.5	-	PG11	55.8	9.5	G 2	G 1 ¼
CMB 3.00T	200	373.3	209.3	36.8	57.5	9	271.5	111.5	160	225.5	-	45	40	160	200	76.5	-	PG11	55.8	9.5	G 2	G 1 ¼
CMB 4.00T	247	428.8	222.3	48	60	12	323.5	133.5	190	264.5	-	60	50	190	240	77.5	-	PG16	65.5	12	G 2	G 1 ¼
CMB 5.50T	247	428.8	222.3	48	60	12	323.5	133.5	190	264.5	-	60	50	190	240	77.5	-	PG16	65.5	12	G 2	G 1 ¼
CMC 0.75M	186	313.3	186.8	36.8	43	9	247	97	150	-	198	45	40	140	180	63.5	PG11	-	57.3	9.5	G 2	G 2
CMC 0.75T	186	313.3	186.8	36.8	43	9	247	97	150	197.5	-	45	40	140	180	63.5	-	PG11	57.3	9.5	G 2	G 2
CMC 1.00M	186	313.3	186.8	36.8	43	9	247	97	150	-	198	45	40	140	180	63.5	PG11	-	57.3	9.5	G 2	G 2
CMC 1.00T	186	313.3	186.8	36.8	43	9	247	97	150	197.5	-	45	40	140	180	63.5	-	PG11	57.3	9.5	G 2	G 2
CMD 1.50M	213	384.3	222.8	36.8	68	12	271.5	111.5	160	-	243.5	45	40	160	200	100.5	PG13.5	-	69.3	9.5	G 2 ½	G 2 ½
CMD 1.50T	213	384.3	222.8	36.8	68	12	271.5	111.5	160	225.5	-	45	40	160	200	100.5	-	PG11	69.3	9.5	G 2 ½	G 2 ½
CMD 2.00M	213	397.3	222.8	36.8	68	12	271.5	111.5	160	-	243.5	45	40	160	200	100.5	PG13.5	-	69.3	9.5	G 2 ½	G 2 ½
CMD 2.00T	213	384.3	222.8	36.8	68	12	271.5	111.5	160	225.5	-	45	40	160	200	100.5	-	PG11	69.3	9.5	G 2 ½	G 2 ½
CMD 3.00T	213	397.3	222.8	36.8	68	12	271.5	111.5	160	225.5	-	45	40	160	200	100.5	-	PG11	69.3	9.5	G 2 ½	G 2 ½
CMD 4.00T	213	449.3	234.8	36.8	68	12	271.5	111.5	160	354	-	45	50	160	200	100.5	-	PG16	69.3	9.5	G 2 ½	G 2 ½

CENTRIFUGAL PUMPS

CMA-B-C-D

PACKING AND WEIGHT

50Hz

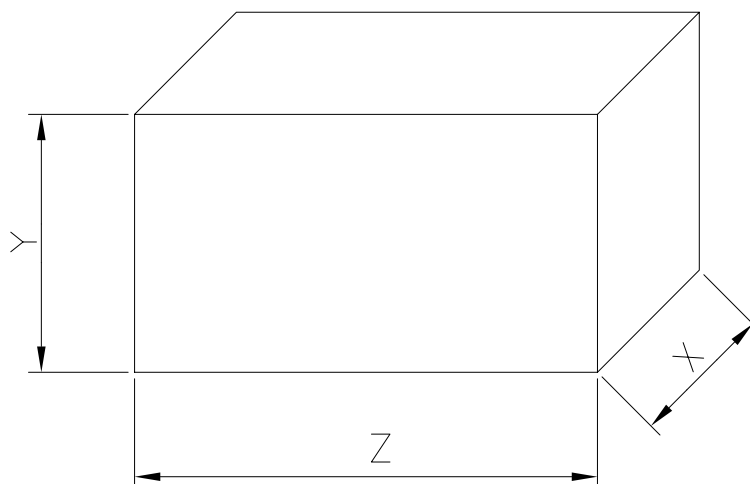

Type pumps		PACKING [mm]			WEIGHT [kg]
		X	Y	Z	
CMA 0.50M	CMA 0.50T	205	235	277	7.3
CMA 0.75M	CMA 0.75T	210	265	320	11.7
CMA 0.80M	CMA 0.80T	210	265	320	10.7
CMA 1.00M	CMA 1.00T	210	265	320	12
CMA 1.50M	CMA 1.50T	225	285	360	19.4
CMA 2.00M	CMA 2.00T	250	320	360	21.3
-	CMA 3.00T	250	320	360	22
CMB 0.75M	CMB 0.75T	215	280	335	12.5
CMB 1.00M	CMB 1.00T	215	280	335	13.8
CMB 1.50M	CMB 1.50T	215	280	365	20.5
CMB 2.00M	CMB 2.00T	235	300	375	21.5
-	CMB 3.00T	235	300	375	21.5
-	CMB 4.00T	272	352	440	39
-	CMB 5.50T	272	352	440	41
CMC 0.75M	CMC 0.75T	210	280	335	12
CMC 1.00M	CMC 1.00T	210	280	335	13
CMD 1.50M	CMD 1.50T	238	300	400	22
CMD 2.00M	CMD 2.00T	238	300	400	24
-	CMD 3.00T	238	300	400	24
-	CMD 4.00T	238	300	460	31.5

CENTRIFUGAL PUMPS

CMA-B-C-D

TECHNICAL DATA

50Hz

Type pumps		kW	HP	Locked rotor current			Capacitor		Input in [kW]		Full load current in [A]		
Single phase 230 V 50 Hz	Three Phase 230/400 V 50 Hz			Single phase 230 V	Three Phase		Single phase µF	VI	Single Phase	Three Phase	Single Phase		Three Phase
					230 V	230 V					400 V	230 V	
CMA 0.50M	CMA 0.50T	0.37	0.5	10.6	9.9	5.7	10	450	0.66	0.63	3.2	2.4	1.4
CMA 0.75M	CMA 0.75T	0.55	0.75	16.1	17	9.8	16	450	1.02	0.97	4.7	3.2	1.8
CMA 0.80M	CMA 0.80T	0.59	0.8	16.1	17	9.8	16	450	1.05	1	4.8	3.3	1.9
CMA 1.00M	CMA 1.00T	0.75	1	24	24.4	14.1	20	450	1.35	1.29	6.2	4.3	2.5
CMA 1.50M	CMA 1.50T	1.1	1.5	38	34.6	20	35	450	1.9	1.85	9.2	5.7	3.3
CMA 2.00M	CMA 2.00T	1.5	2	43	41.2	23.8	40	450	2.4	2.3	10.8	7.8	4.5
-	CMA 3.00T	2.2	3	-	49.5	28.6	-	-	-	3	-	9.9	5.7
CMB 0.75M	CMB 0.75T	0.55	0.75	13.3	11.2	6.5	14	450	0.98	0.95	4.5	3.0	1.7
CMB 1.00M	CMB 1.00T	0.75	1	24	24.4	14.1	20	450	1.33	1.28	6	4	2.3
CMB 1.50M	CMB 1.50T	1.1	1.5	38	34.6	20	31.5	450	1.77	1.73	8.5	5.5	3.2
CMB 2.00M	CMB 2.00T	1.5	2	43	41.2	23.8	40	450	2.3	2.2	10.8	7.5	4.3
-	CMB 3.00T	2.2	3	-	49.5	28.6	-	-	-	2.65	-	8.3	4.8
-	CMB 4.00T	3	4	-	84.1	48.6	-	-	-	3.7	-	12.5	7.2
-	CMB 5.50T	4	5.5	-	129.8	75	-	-	-	4.9	-	16.3	9.4
CMC 0.75M	CMC 0.75T	0.55	0.75	13.3	11.2	6.5	14	450	0.92	0.9	4.2	2.8	1.6
CMC 1.00M	CMC 1.00T	0.75	1	24	24.4	14.1	20	450	1.15	1.1	5.3	3.5	2
CMD 1.50M	CMD 1.50T	1.1	1.5	38	34.6	20	31.5	450	1.86	1.8	8.9	5.9	3.4
CMD 2.00M	CMD 2.00T	1.5	2	43	41.2	23.8	40	450	2.3	2.2	10.8	7.5	4.3
-	CMD 3.00T	2.2	3	-	49.5	28.6	-	-	-	2.9	-	9	5.2
-	CMD 4.00T	3	4	-	84.1	48.6	-	-	-	3.85	-	12.3	7.1

Type pumps		Ball Bearing	
Single phase 230 V	Three Phase 230/400 V	Pump side	Fan side
CMA 0.50M	CMA 0.50T	6201 ZZ	6202 ZZ
CMA 0.75M	CMA 0.75T	6202 ZZ	6202 ZZ
CMA 0.80M	CMA 0.80T	6202 ZZ	6202 ZZ
CMA 1.00M	CMA 1.00T	6202 ZZ	6202 ZZ
CMA 1.50M	CMA 1.50T	6204 ZZ	6203 ZZ
CMA 2.00M	CMA 2.00T	6204 ZZ	6203 ZZ
-	CMA 3.00T	6204 ZZ	6203 ZZ
CMB 0.75M	CMB 0.75T	6202 ZZ	6202 ZZ
CMB 1.00M	CMB 1.00T	6202 ZZ	6202 ZZ
CMB 1.50M	CMB 1.50T	6204 ZZ	6203 ZZ
CMB 2.00M	CMB 2.00T	6204 ZZ	6203 ZZ
-	CMB 3.00T	6204 ZZ	6203 ZZ
-	CMB 4.00T	6306 ZZ	6205 ZZ
-	CMB 5.50T	6306 ZZ	6205 ZZ
CMC 0.75M	CMC 0.75T	6202 ZZ	6202 ZZ
CMC 1.00M	CMC 1.00T	6202 ZZ	6202 ZZ
CMD 1.50M	CMD 1.50T	6204 ZZ	6203 ZZ
CMD 2.00M	CMD 2.00T	6204 ZZ	6203 ZZ
-	CMD 3.00T	6204 ZZ	6203 ZZ
-	CMD 4.00T	6206 ZZ	6205 ZZ

500