

### Technical Specifications

Pump Code	F50-P3-3	Pump Housing Material	Polypropylene
Max. Flow Rate	596 lpm	Center Section Material	Polypropylene
Max. Pump Speed	145 cpm	Max. Size Pumpable Solids	6.2 mm
Displacement per cycle	4.11 liter	Max. Suction Lift	9.5 m (Wet) 6 m (Dry)
Fluid Inlet- Outlet Size	2" ANSI Flange	Max. Operating Temperature	80 °C
Air Inlet Size	1/2"	Sound Level	82 dBa (at 5 bar)
Max. Fluid Working Pressure	8 bar	Diaphragm Material	Hytrek
Max. Air Consumption (at 5 bar)	3.72 m <sup>3</sup> /min	Check-Valve Material	Acetal ball & Hytrek seat
Ratio	1:1	Weight	28.3 kg

### Performance Curves

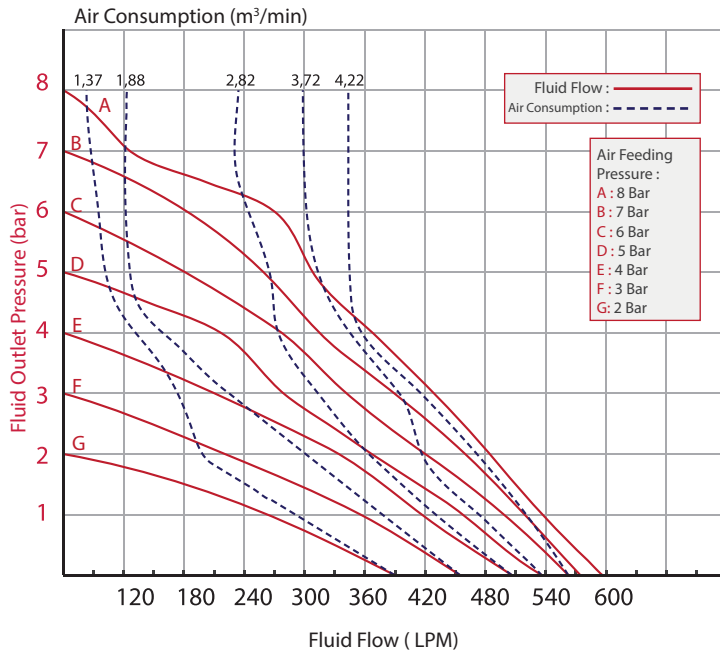

**Made in Turkey**



**Test Conditions:** All tests are made with water. Suction hose submerged in the fluid. Muffler not used. All the values are shown are approximate and not binding.

**Example:** To pump 392 lpm against a discharge pressure of 3 bar, requires 7 bar and 3,72 m<sup>3</sup>/min air consumption.

### Dimensions

A	475
B	780
C	152
D	16
E	595
F	317
G	344
H	210
I	14

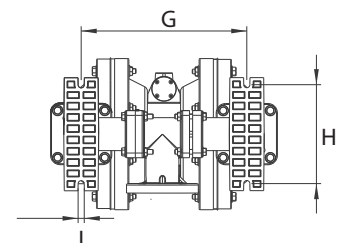
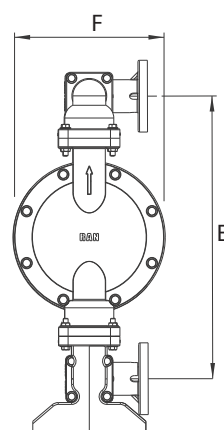
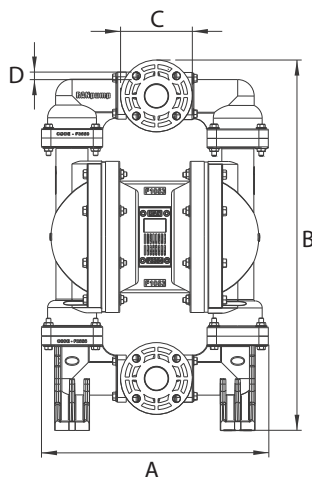

Tüm ölçüler mm'dir.