



Basic Pedestal Standard Centrifugal Pump

Model 55A2-B

Size 6" x 5"

PUMP SPECIFICATIONS

Size: 6" x 5" (152 x 101 mm) Flanged.

Casing: Gray Iron 30.

Maximum Operating Pressure 235 psi (1620 kPa).*

Enclosed Type, Six Vane Impeller: Gray Iron 30.

Handles 1/2" (12,7 mm) Diameter Spherical Solids.

Impeller Shaft: Alloy Steel 4150.

Replaceable Wear Ring: Copper Alloy C93800.

Pedestal: Gray Iron 30.

Seal Housing: Copper Alloy C83600.

Radial Bearing: Open Single Row Ball.

Thrust Bearing: Open Double Row Ball.

Bearing Lubrication: SAE 30 Non-Detergent Oil.

Cover Plate: Gray Iron 30.

Gaskets: Vegetable Fiber.

Hardware: Standard Plated Steel.

Oil Level Sight Gauge.

Strainer.



Optional Equipment: 6" NPT Suction Flange. 5" NPT Discharge Flange. Hand Primer. Discharge Check Valve.

*Consult Factory for Applications Exceeding Maximum Pressure and/or Temperature Indicated.

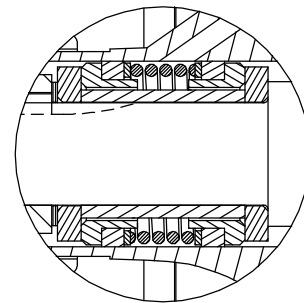
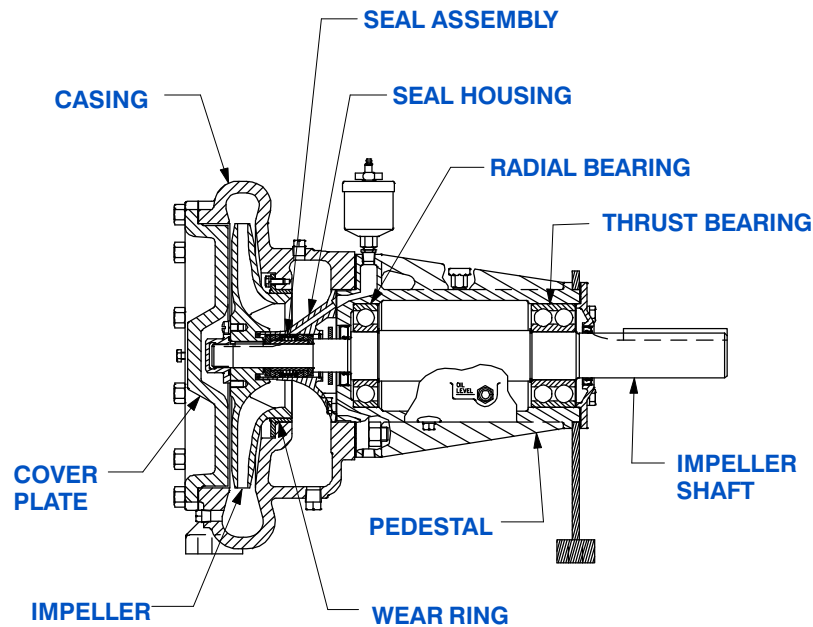

SEAL DETAIL

Double, Grease Lubricated with Spring-Loaded Grease Cup. Sintered Bronze Stationary Seal Seats. Steel Rotating Faces. Neoprene Packing Rings. Maximum Temperature of Liquid Pumped, 110°F (43°C). Maximum Suction Pressure 10 psi (69 kPa).*



GORMAN-RUPP PUMPS

www.grpumps.com

Specifications Subject to Change Without Notice

Printed in U.S.A.

Specification Data

SECTION 70, PAGE 900

APPROXIMATE
DIMENSIONS and WEIGHTS

NET WEIGHT: 432 LBS. (196,0 KG.)
SHIPPING WEIGHT: 490 LBS. (222,3 KG.)
EXPORT CRATE: 20.2 CU. FT. (0,57 CU. M.)

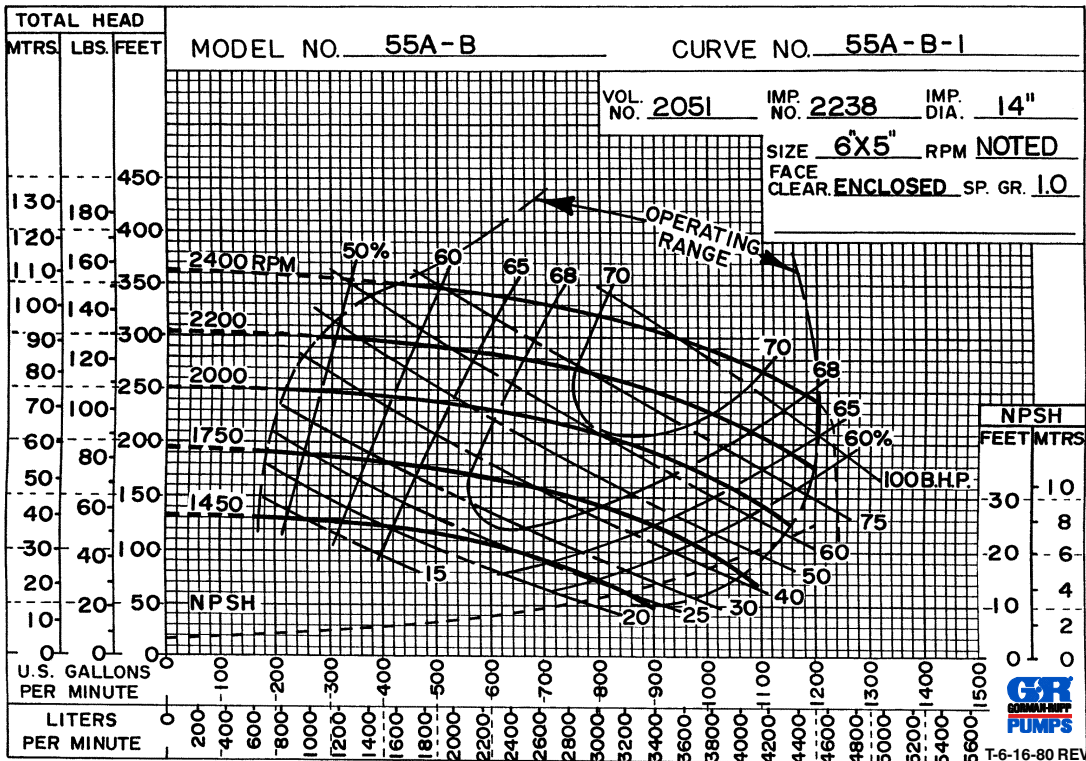
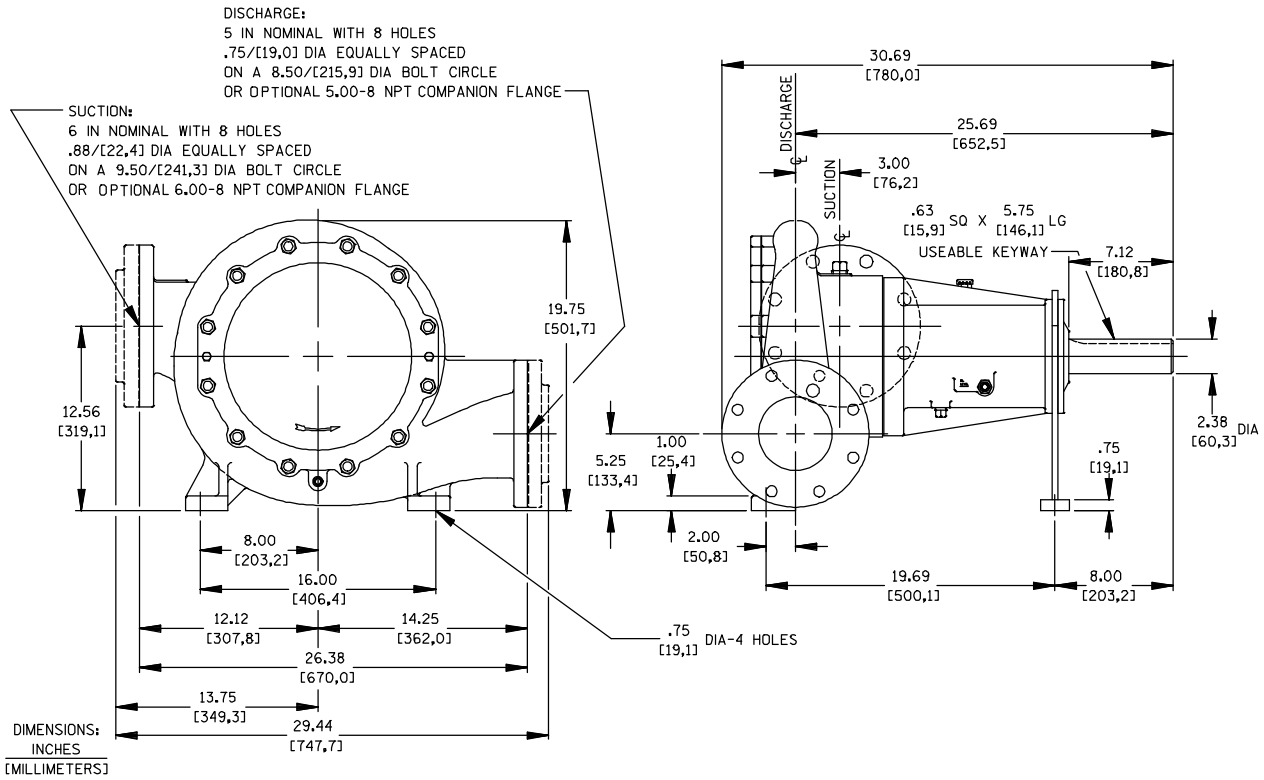

GORMAN-RUPP PUMPS

www.grpumps.com

Specifications Subject to Change Without Notice

Printed in U.S.A.