

A B C D E

Self Priming Centrifugal Pump



Models 82E3-B and 82E52-B

Size 2" x 2"

PUMP SPECIFICATIONS

- Size:** 2" x 2" (51 mm x 51 mm) NPT - Female.
- Casing:** Gray Iron 30.
Maximum Operating Pressure 86 psi (593 kPa)*.
- Semi-Open Type, Four Vane Impeller:** Gray Iron 30.
Handles 3/4" (19 mm) Diameter Spherical Solids.
- Impeller Shaft:** Carbon Steel 1045.
- Replaceable Wear Plate:** Carbon Steel 1026.
- Pedestal:** Gray Iron 30.
- Shaft Sleeve:** (82E3-B) Alloy Steel 4130.
(82E52-B) Stainless Steel 304.
- Seal Plate:** Gray Iron 30.
- Flap Valve:** Buna-N w/Nylon Reinforcement,
Gray Iron 30 and Steel.
- Radial and Thrust Bearings:** Open Single Row Ball.
- Bearing Lubrication:** SAE 30 Non-Detergent Oil.
- Flange:** Gray Iron 30.
- Gaskets:** Cork.
- Hardware:** Standard Plated Steel.
- Optional Equipment:**
Galvanized Ductile Iron Discharge Elbow.
Consult Factory for Additional Options.



**Consult Factory for Applications Exceeding Maximum Pressure and/or Temperature Indicated.*

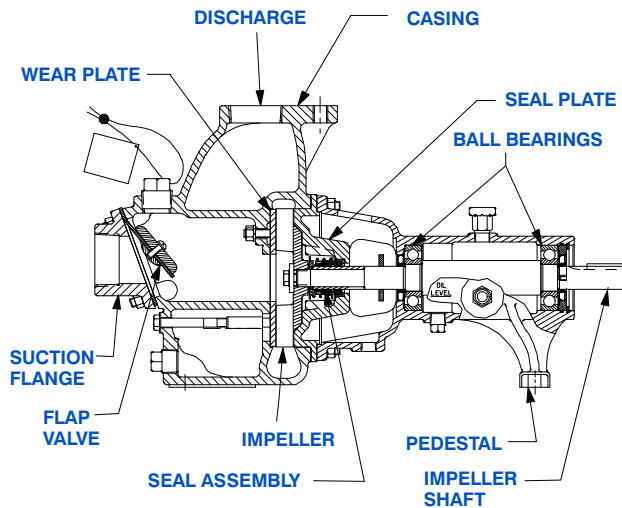

82E3-B SHOWN

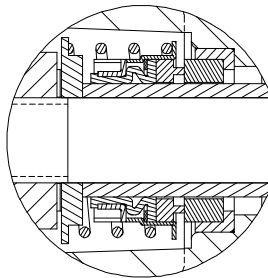

82E3-B SEAL DETAIL Type 2, Mechanical, Self-Lubricated. Carbon Rotating Face. Ceramic Stationary Face. Buna-N Elastomers. Stainless Steel 18-8 Cage and Spring. Maximum Temperature of Liquid Pumped 160°F (71 °C).*

82E52-B SEAL DETAIL Type 31, Mechanical, Self-Lubricated. Silicon Carbide Rotating and Stationary Faces. Fluorocarbon Elastomers (DuPont Viton® or Equivalent). Stainless Steel 18-8 Cage and Spring. Maximum Temperature of Liquid Pumped 160°F (71 °C).*

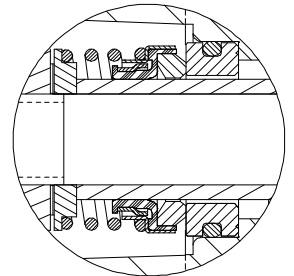

THE GORMAN-RUPP COMPANY • MANSFIELD, OHIO

GORMAN-RUPP OF CANADA LIMITED • ST. THOMAS, ONTARIO, CANADA

www.grpumps.com

Specifications Subject to Change Without Notice

Printed in U.S.A.

Specification Data

SECTION 50, PAGE 1101

APPROXIMATE
DIMENSIONS and WEIGHTS

NET WEIGHT: 90 LBS. (40,8 KG.)

SHIPPING WEIGHT: 100 LBS. (45,4 KG.)

EXPORT CRATE: 7.9 CU. FT. (0,22 CU. M.)

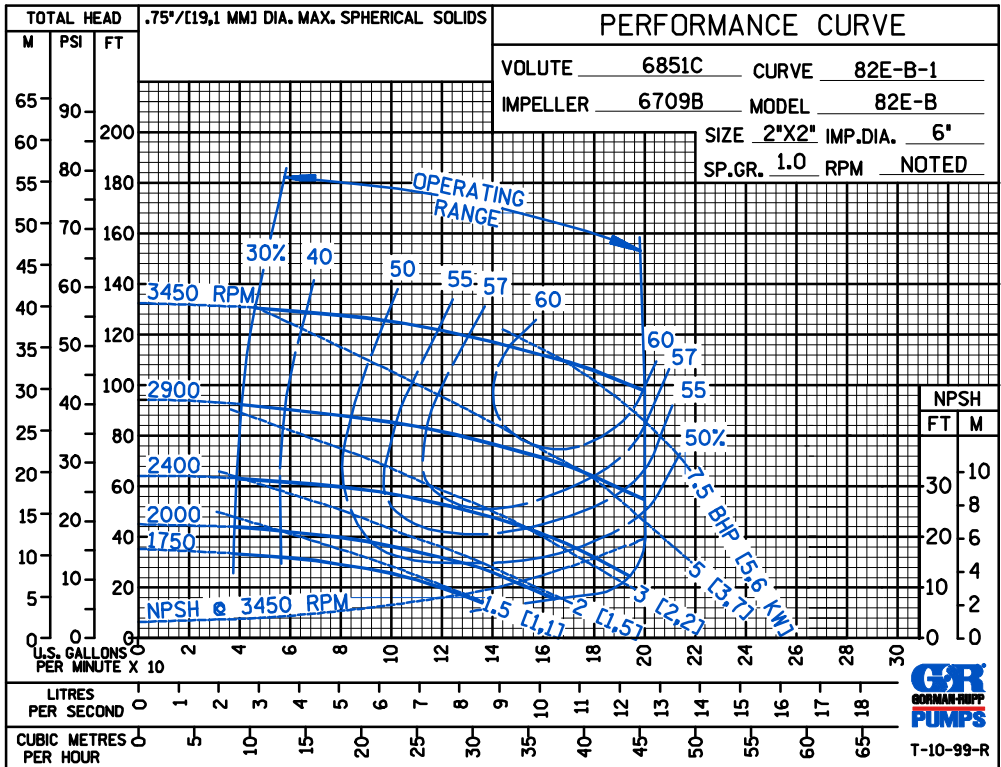
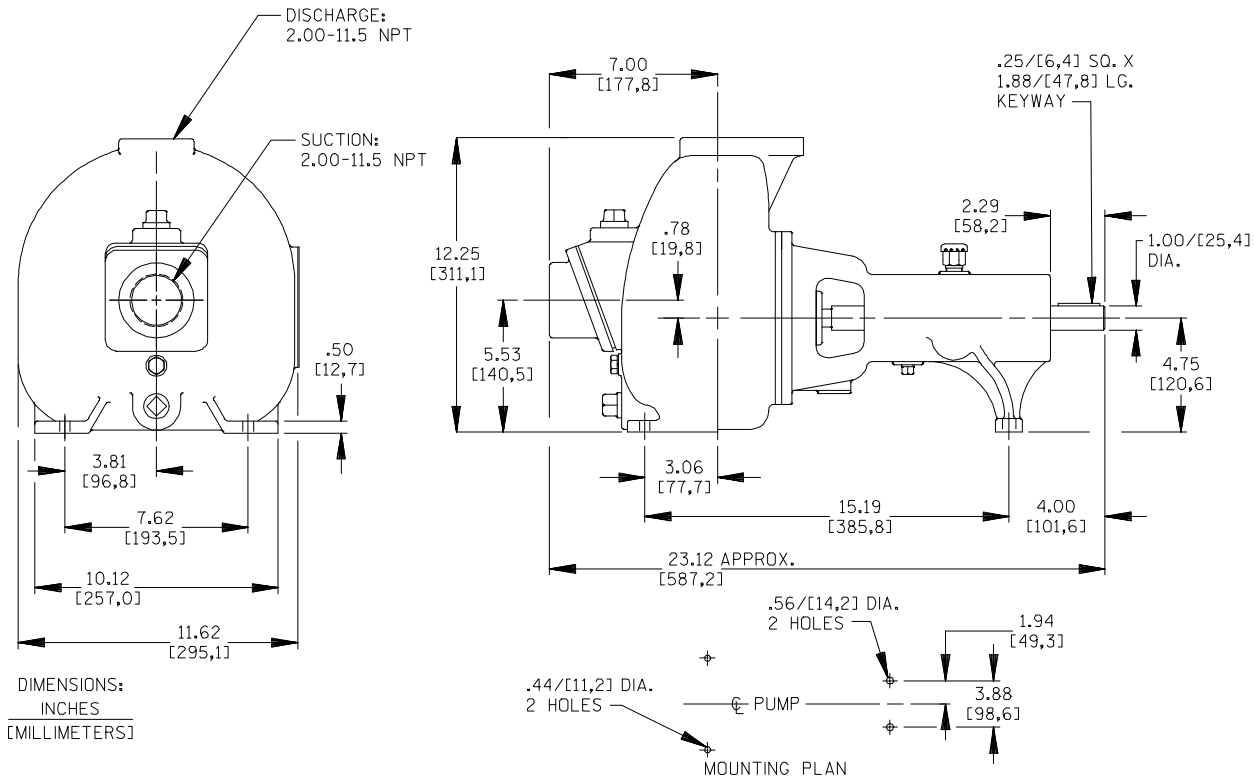

THE GORMAN-RUPP COMPANY • MANSFIELD, OHIO

GORMAN-RUPP OF CANADA LIMITED • ST. THOMAS, ONTARIO, CANADA

Specifications Subject to Change Without Notice

Printed in U.S.A.

A B C D E

TRIMMED
IMPELLER

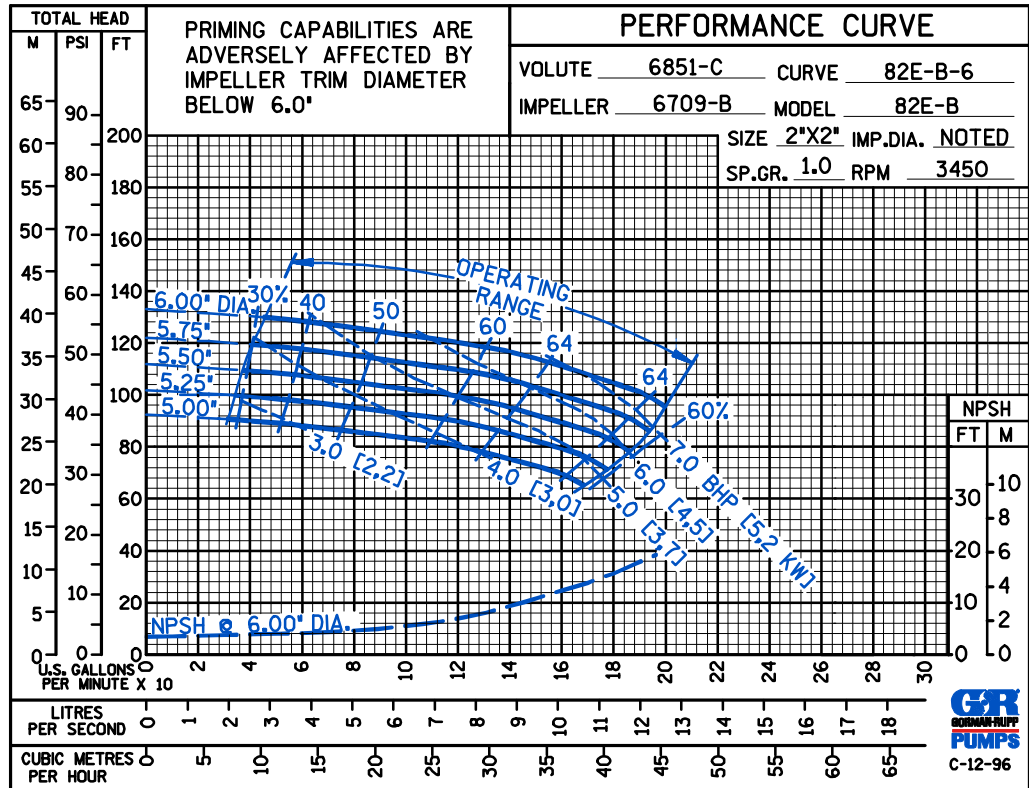

PERFORMANCE
BASED ON
PETROLEUM

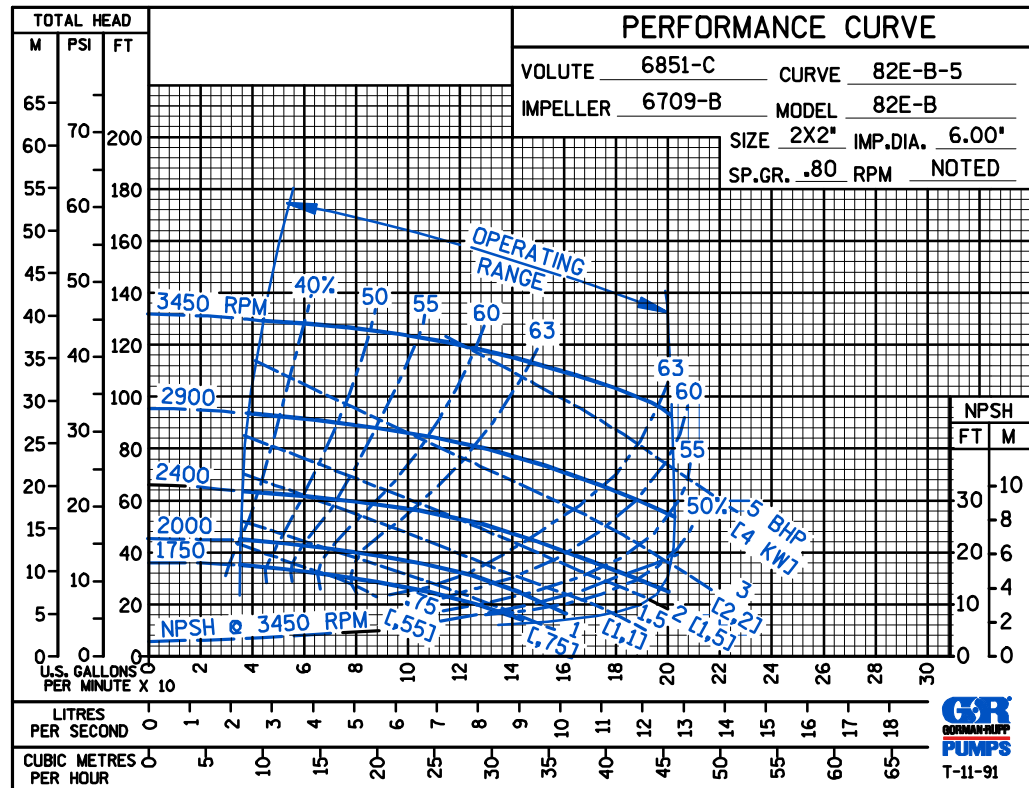

THE GORMAN-RUPP COMPANY • MANSFIELD, OHIO

GORMAN-RUPP OF CANADA LIMITED • ST. THOMAS, ONTARIO, CANADA

Specifications Subject to Change Without Notice

Printed in U.S.A.