

Basic Pedestal

A B C D E

Self Priming Centrifugal Pump



Models 82D3-B and 82D52-B

Size 2" x 2"

PUMP SPECIFICATIONS

- Size:** 2" x 2" (51 mm x 51 mm) NPT - Female.
- Casing:** Gray Iron 30.
Maximum Operating Pressure 69 psi (476 kPa)*.
- Semi-Open Type, Three Vane Impeller:**
Ductile Iron 65-45-12.
Handles 5/8" (15,8 mm) Diameter Spherical Solids.
- Impeller Shaft:** Carbon Steel 1215
- Replaceable Wear Plate:** Carbon Steel 1026.
- Pedestal:** Gray Iron 30.
- Shaft Sleeve:** Stainless Steel 304.
- Seal Plate:** Gray Iron 30.
- Flap Valve:** Buna-N^w/Nylon Reinforcement,
Gray Iron 30 and Steel.
- Radial and Thrust Bearings:** Open Single Row Ball.
- Bearing Lubrication:** Grease.
- Flange:** Gray Iron 30.
- Gaskets:** Cork.
- Hardware:** Standard Plated Steel.
- Optional Equipment:**
Galvanized Ductile Iron Discharge Elbow.
Consult Factory for Additional Options.



**Consult Factory for Applications Exceeding Maximum Pressure and/or Temperature Indicated.*

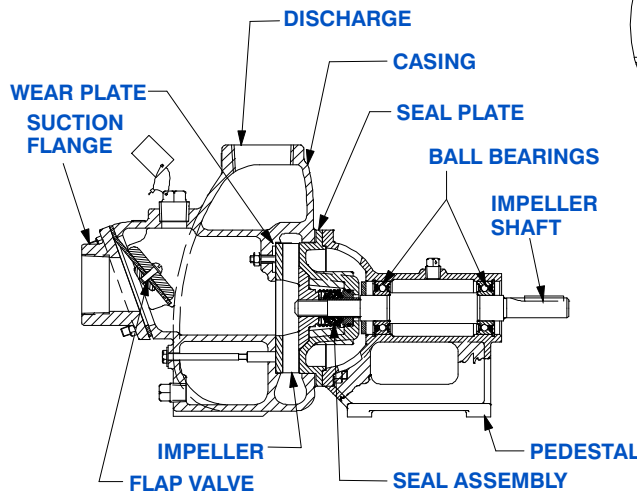

82D3-B SHOWN

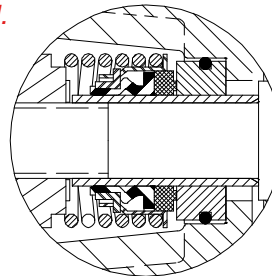

82D3-B SEAL DETAIL Type 2, Mechanical, Self-Lubricated. Carbon Rotating Face. Ceramic Stationary Face. Buna-N Elastomers. Stainless Steel 18-8 Cage and Spring. Maximum Temperature of Liquid Pumped, 160°F (71 °C).*

82D52-B SEAL DETAIL Type 31, Mechanical, Self-Lubricated. Silicon Carbide Rotating and Stationary Faces. Fluorocarbon Elastomers (DuPont Viton[®] or Equivalent). Stainless Steel 316 Cage and Spring. Maximum Temperature of Liquid Pumped 160°F (71 °C).*

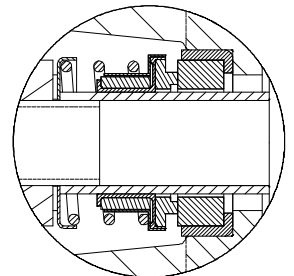

THE GORMAN-RUPP COMPANY • MANSFIELD, OHIO

GORMAN-RUPP OF CANADA LIMITED • ST. THOMAS, ONTARIO, CANADA

www.grpumps.com

Specifications Subject to Change Without Notice

Printed in U.S.A.

A B C D E

PERFORMANCE
BASED ON
PETROLEUM

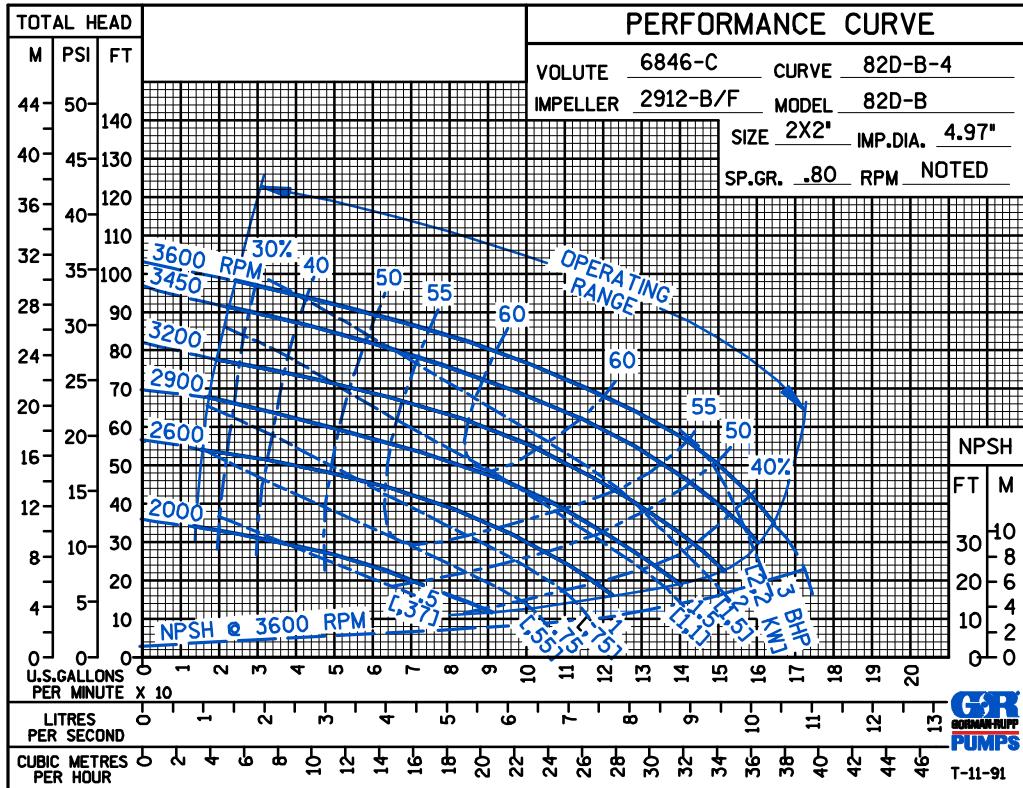

50 HERTZ

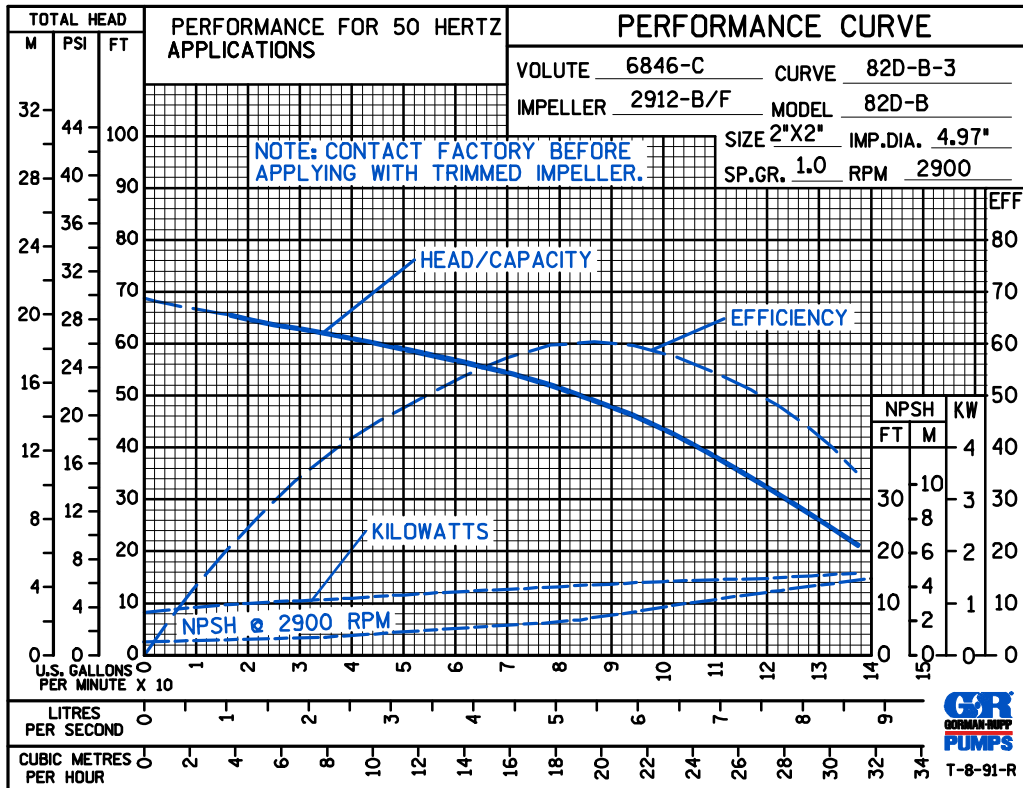

THE GORMAN-RUPP COMPANY • MANSFIELD, OHIO

GORMAN-RUPP OF CANADA LIMITED • ST. THOMAS, ONTARIO, CANADA

Specifications Subject to Change Without Notice

Printed in U.S.A.