

CDSW

Self Priming Centrifugal Pump

Super
T SERIES

VARIOUS PATENTS APPLY

Model T8A61S-B

Size 8" x 8"



PUMP SPECIFICATIONS

Size: 8" (203 mm) ASA Flanged Suction x 8" (203 mm) NPT Female Discharge.

Casing: Gray Iron 30.

Maximum Operating Pressure 83 psi (572 kPa).*

Semi-Open Type, Two Vane Impeller: Stainless Steel 316.

Handles 3" (76,2 mm) Diameter Spherical Solids.

Impeller Shaft: Stainless Steel 17-4 PH.

Replaceable Wear Plate: Stainless Steel 316.

Removable Adjustable Cover Plate: Gray Iron 30; 94 lbs. (43 kg).

Flap Valve: Neoprene w/Nylon and Steel Reinforcing.

Seal Plate: Stainless Steel 316.

Bearing Housing: Gray Iron 30.

Radial and Thrust Bearings: Open Double Row Ball.

Bearing and Seal Cavity Lubrication: SAE 30 Non-Detergent Oil.

Flanges: 125# Gray Iron 30.

Gaskets: Buna-N, Compressed Synthetic Fibers, PTFE, Cork, and Rubber.

O-Rings: Buna-N.

Internal Wetted Hardware: Stainless Steel 316.

External Hardware: Standard Plated Steel.

Pressure Relief Valve: Stainless Steel 316.

Bearing and Seal Cavity Oil Level Sight Gauges.

Optional Equipment: Metal Bellows Seal. Automatic Air Release Valve. Stainless Steel CD4MCu Impeller, Seal Plate and Wear Plate. 120V/240V Casing Heater. High Pump Temperature Shutdown Kit. Self-Cleaning Wear Plate. Gray Iron 30 Spool Flanges:

8" ASA Discharge (**Specify Model T8A61S-B /F**).

200 mm DIN 2527 (PN 16) Suction and Discharge (**Specify Model T8A61S-B /FM**).

**Consult Factory for Applications Exceeding Maximum Pressure and/or Temperature Indicated.*



Shown with Optional Discharge Spool Flange (Available in ASA or DIN Standard Sizes).

SEAL SPECIFICATIONS

Mechanical, Oil-Lubricated, Double Floating, Self-Aligning. Silicon Carbide Rotating and Stationary Faces. Stainless Steel 316 Stationary Seat. Fluorocarbon Elastomers (DuPont Viton® or Equivalent). Stainless Steel 18-8 Cage and Spring. Maximum Temperature of Liquid Pumped, 160°F (71°C).*

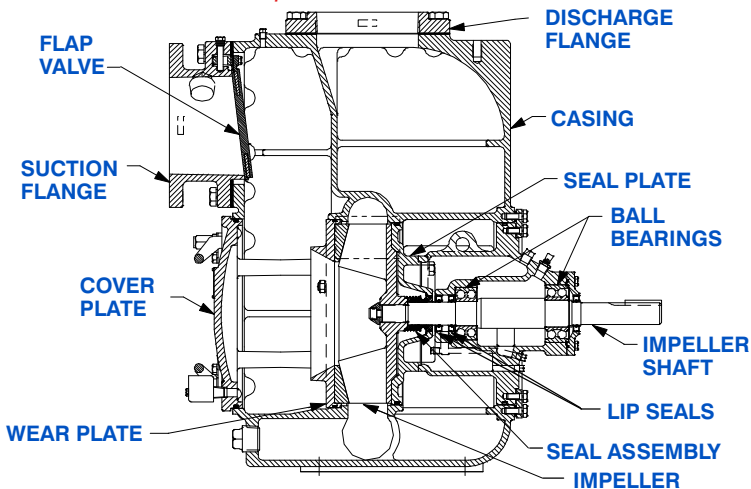

SEAL DETAIL

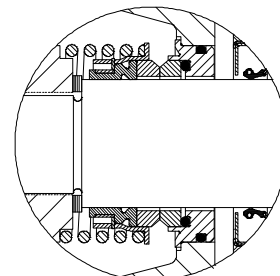

THE GORMAN-RUPP COMPANY • MANSFIELD, OHIO

GORMAN-RUPP OF CANADA LIMITED • ST. THOMAS, ONTARIO, CANADA

www.grpumps.com

Specifications Subject to Change Without Notice

Printed in U.S.A.

Specification Data

SECTION 55, PAGE 2320

APPROXIMATE DIMENSIONS and WEIGHTS

NET WEIGHT: 1332 LBS. (604 KG.)*
SHIPPING WEIGHT: 1399 LBS. (651 KG.)*
EXPORT CRATE: 47.9 CU. FT. (1,36 CU. M.)
***ADD 35 LBS. (15,9 KG.) W/EACH SPOOL FLANGE**

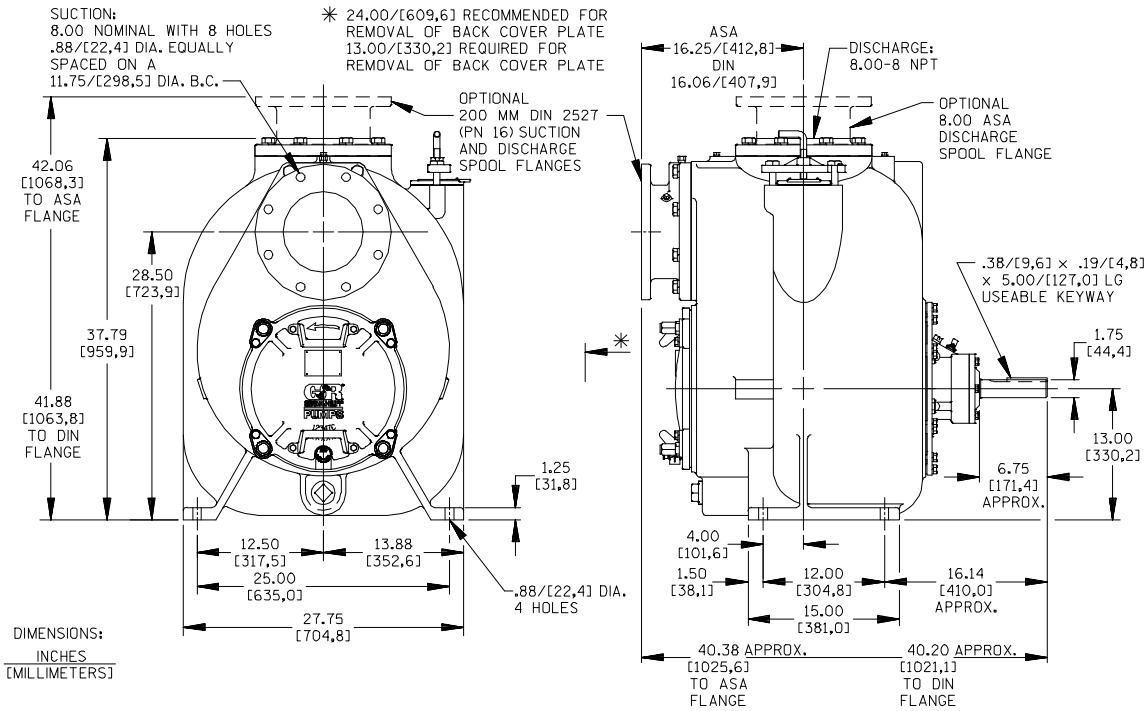

OPTIONAL ASA OR DIN STANDARD SPOOL FLANGES AVAILABLE

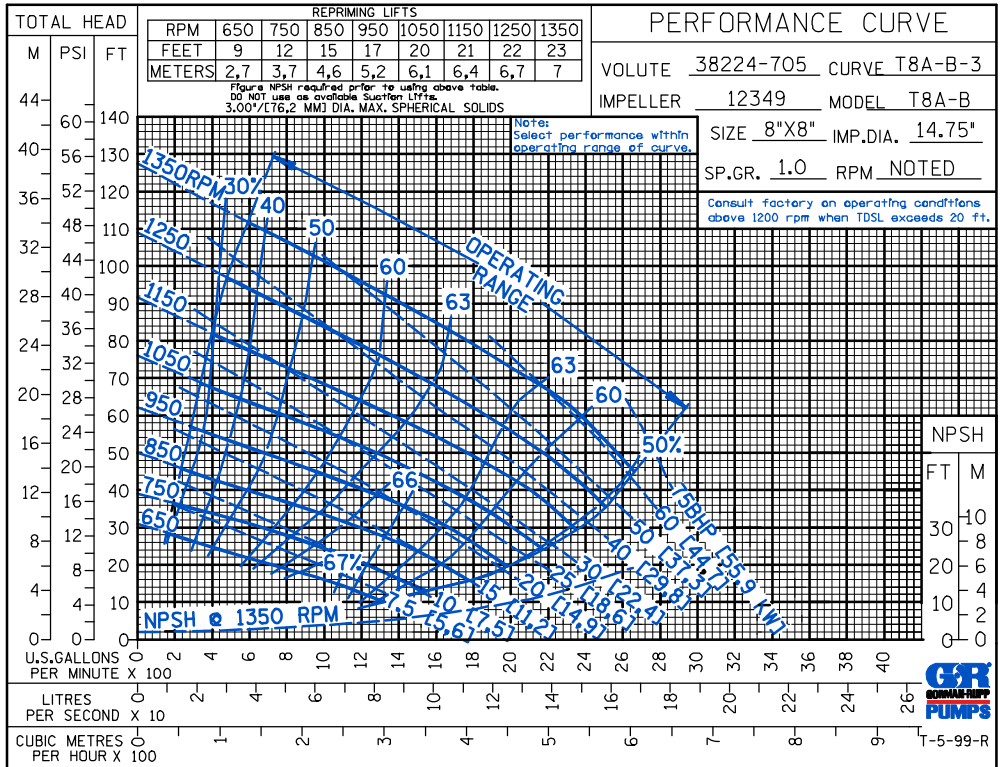

THE GORMAN-RUPP COMPANY • MANSFIELD, OHIO

GORMAN-RUPP OF CANADA LIMITED • ST. THOMAS, ONTARIO, CANADA

Specifications Subject to Change Without Notice

Printed in U.S.A.



THE GORMAN-RUPP COMPANY • MANSFIELD, OHIO

GORMAN-RUPP OF CANADA LIMITED • ST. THOMAS, ONTARIO, CANADA

www.grpumps.com

Specifications Subject to Change Without Notice

© Copyright by the Gorman-Rupp Company 2009

Printed in U.S.A.

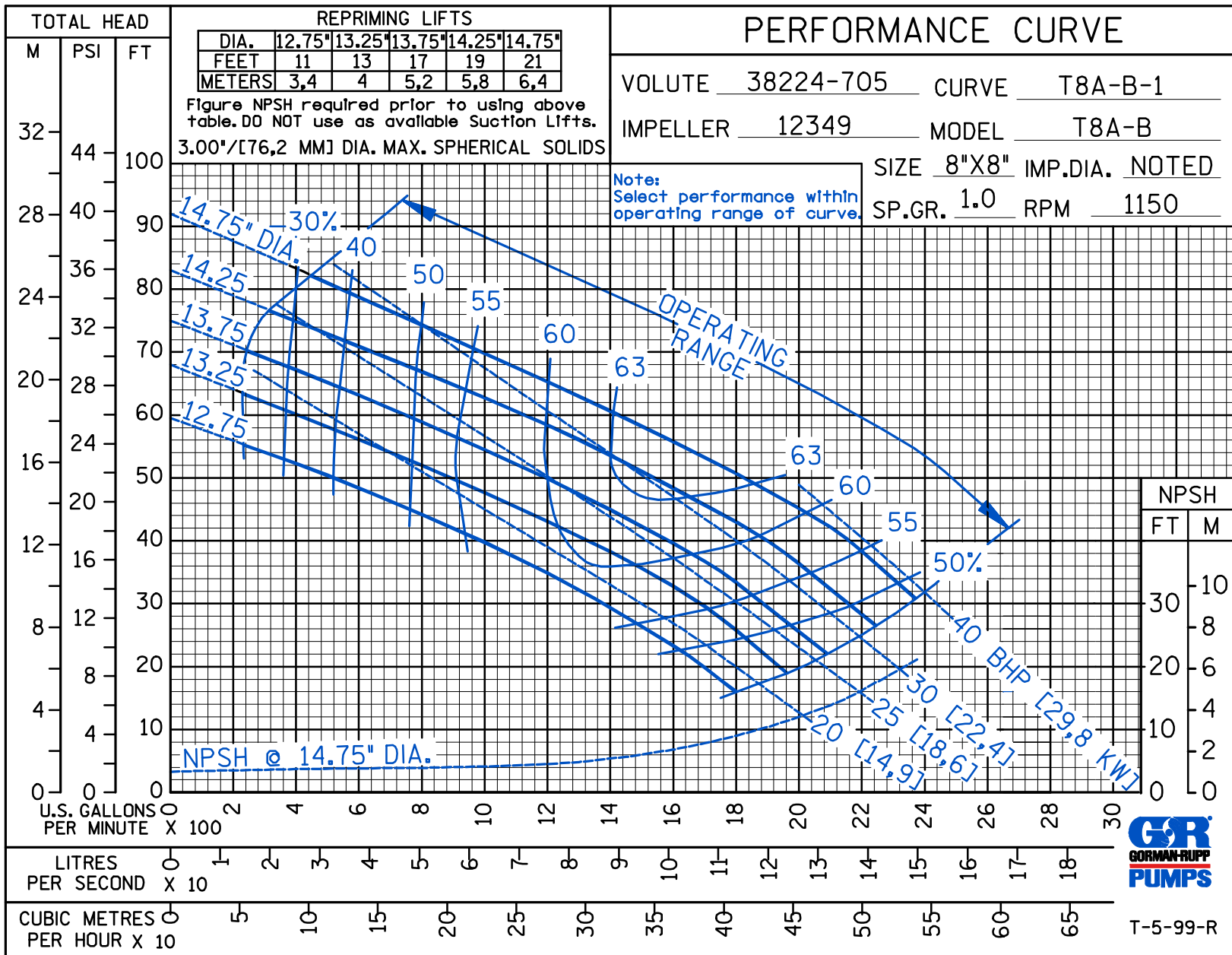

CDS

Curve Data

Sec. 55

PAGE 2351.1
SEPTEMBER 2009



T-5-99-R



THE GORMAN-RUPP COMPANY • MANSFIELD, OHIO
 GORMAN-RUPP OF CANADA LIMITED • ST. THOMAS, ONTARIO, CANADA
 www.grpumps.com

Specifications Subject to Change Without Notice

Printed in U.S.A.

© Copyright by the Gorman-Rupp Company 2009

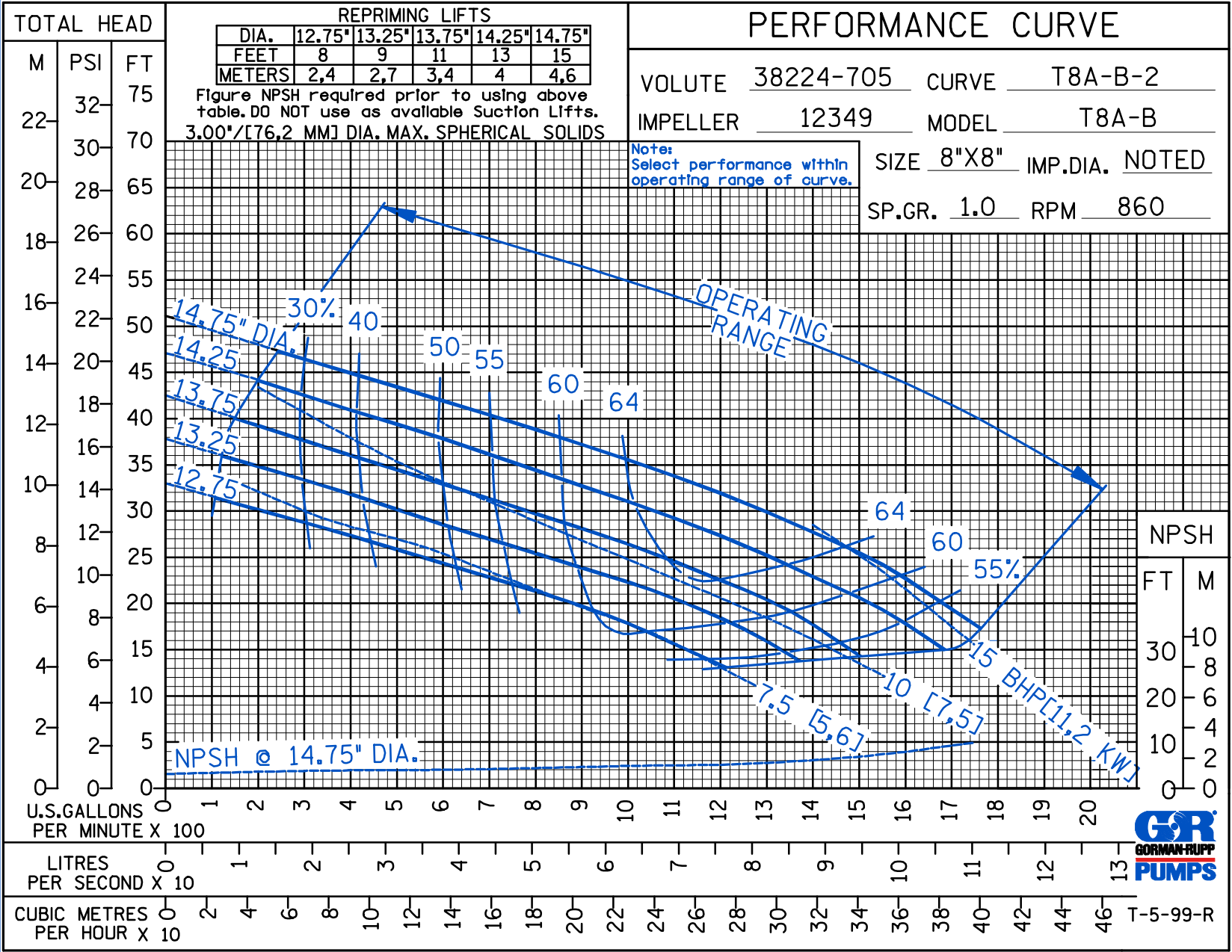

CDS

Curve Data

Sec. 55

PAGE 2351.2
 SEPTEMBER 2009



T-5-99-R

CDS

PERFORMANCE CURVE

VOLUTE 38224-705 CURVE T8A-B-3

IMPELLER 12349 MODEL T8A-B

SIZE 8"X8" IMP.DIA. 14.75"

SP.GR. 1.0 RPM NOTED

Consult factory on operating conditions above 1200 rpm when TDSL exceeds 20 ft.

| REPRIMING LIFTS | | | | | | | | |
|-----------------|-----|-----|-----|-----|------|------|------|------|
| RPM | 650 | 750 | 850 | 950 | 1050 | 1150 | 1250 | 1350 |
| FEET | 9 | 12 | 15 | 17 | 20 | 21 | 22 | 23 |
| METERS | 2,7 | 3,7 | 4,6 | 5,2 | 6,1 | 6,4 | 6,7 | 7 |

Figure NPSH required prior to using above table.
DO NOT use as available Suction Lifts.
3.00"/[76,2 MM] DIA. MAX. SPHERICAL SOLIDS

Note:
Select performance within
operating range of curve.

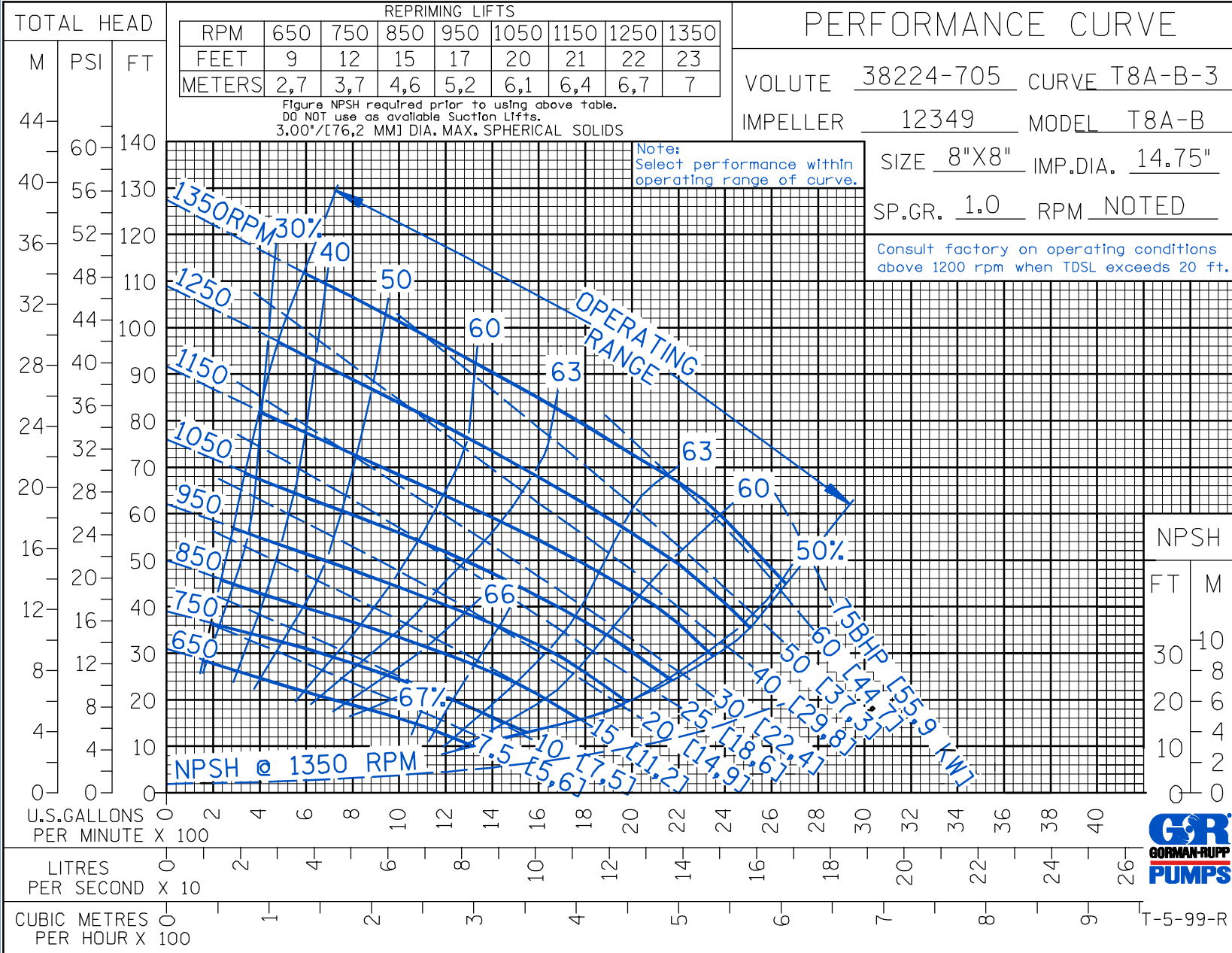

NPSH

FT M

30 10

8 8

20 6

10 4

0 0

26

T-5-99-R

GORMAN-RUPP PUMPS



THE GORMAN-RUPP COMPANY • MANSFIELD, OHIO

GORMAN-RUPP OF CANADA LIMITED • ST. THOMAS, ONTARIO, CANADA

www.grpumps.com

Specifications Subject to Change Without Notice

Printed in U.S.A.

CDS

PERFORMANCE CURVE

VOLUTE 38224-705 CURVE T8A-B-4
 IMPELLER 12349 MODEL T8A-B
 SIZE 8"X8" IMP.DIA. 14.25"
 SP.GR. 1.0 RPM NOTED

Consult factory on operating conditions above 1200 rpm when TDSL exceeds 20 ft.

Note:
Select performance within operating range of curve.

| REPRIMING LIFTS | | | | | | | | | |
|-----------------|-----|-----|-----|-----|------|------|------|------|------|
| RPM | 650 | 750 | 850 | 950 | 1050 | 1150 | 1250 | 1350 | 1450 |
| FEET | 8 | 10 | 13 | 16 | 18 | 19 | 21 | 23 | 24 |
| METERS | 2,4 | 3,1 | 4 | 4,9 | 5,5 | 5,8 | 6,4 | 7 | 7,3 |

Figure NPSH required prior to using above table.
 DO NOT use as available Suction Lifts.
 3.00"/[76,2 MM] DIA. MAX. SPHERICAL SOLIDS

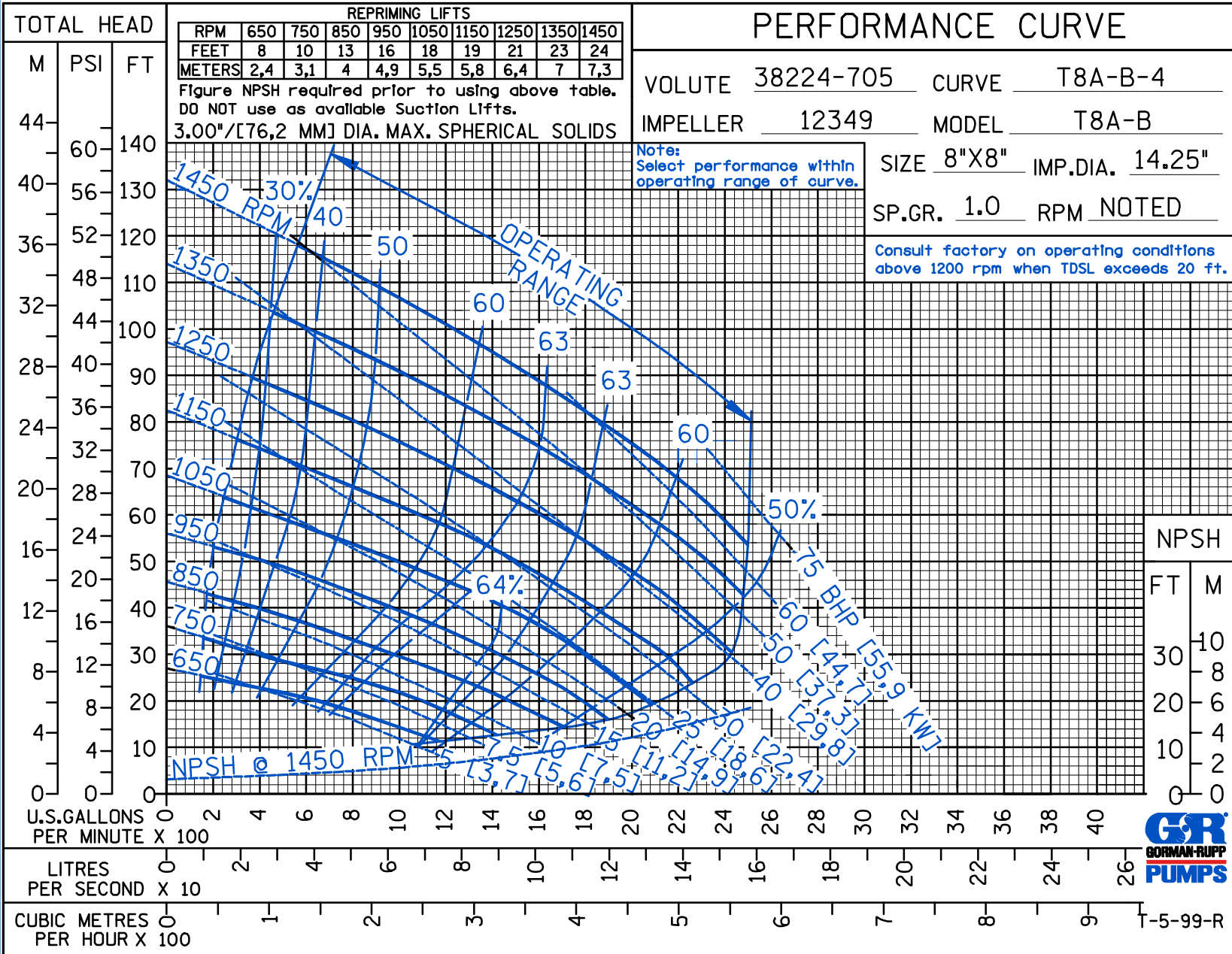

T-5-99-R



THE GORMAN-RUPP COMPANY • MANSFIELD, OHIO
 GORMAN-RUPP OF CANADA LIMITED • ST. THOMAS, ONTARIO, CANADA

www.grpumps.com
 Specifications Subject to Change Without Notice

Printed in U.S.A.



THE GORMAN-RUPP COMPANY • MANSFIELD, OHIO
 GORMAN-RUPP OF CANADA LIMITED • ST. THOMAS, ONTARIO, CANADA
 www.grpumps.com

© Copyright by the Gorman-Rupp Company 2009

Specifications Subject to Change Without Notice

Printed in U.S.A.

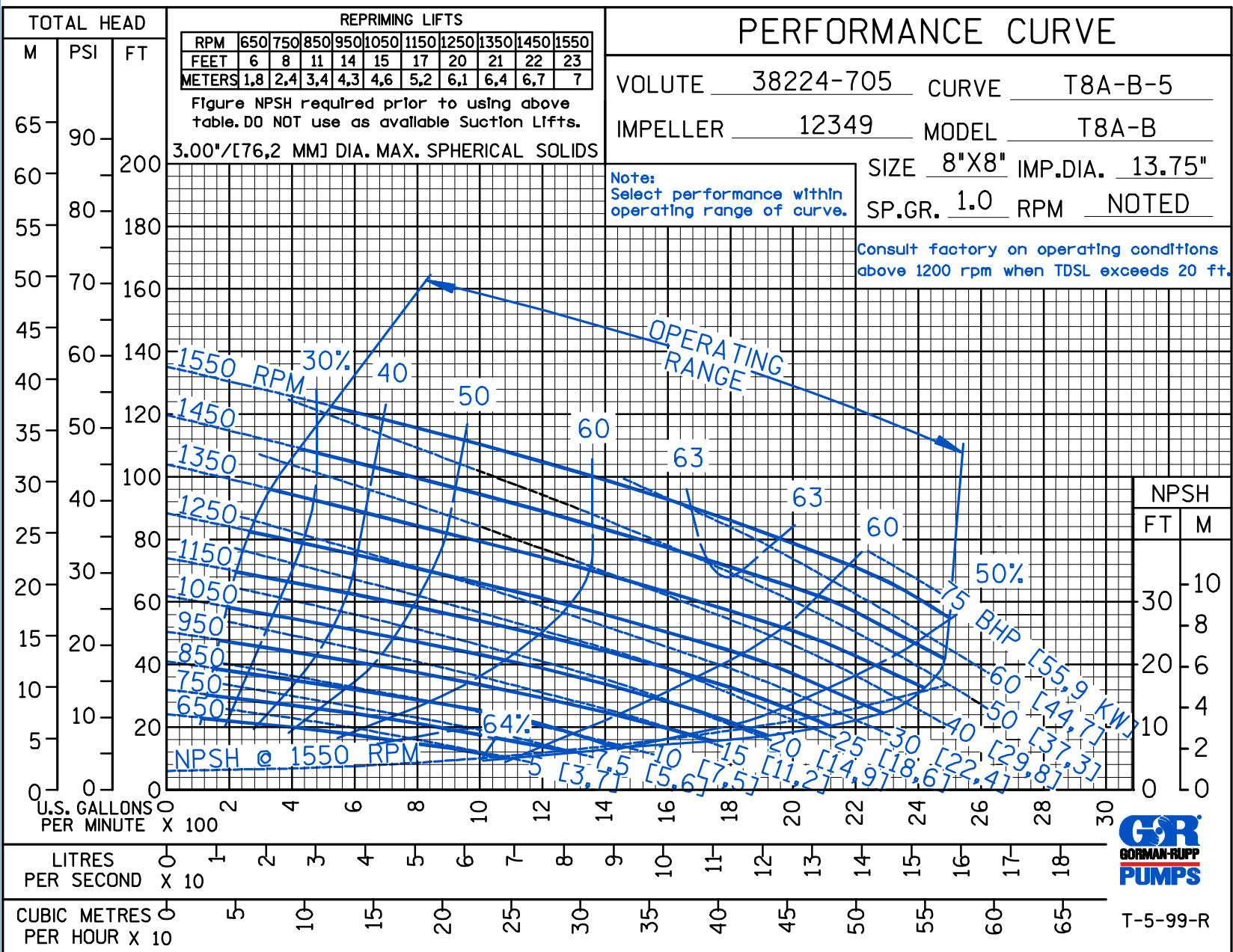

T-5-99-R

CDS

Curve Data

Sec. 55

PAGE 2351.5
 SEPTEMBER 2009

CDS

PERFORMANCE CURVE

VOLUTE 38224-705 CURVE T8A-B-6
 IMPELLER 12349 MODEL T8A-B
 SIZE 8"X8" IMP.DIA. 13.25"
 SP.GR. 1.0 RPM NOTED

Consult factory on operating conditions above 1200 rpm when TDSL exceeds 20 ft.

Note:
Select performance within operating range of curve.

| REPRIMING LIFTS | | | | | | | | | | |
|-----------------|-----|-----|-----|-----|------|------|------|------|------|------|
| RPM | 650 | 750 | 850 | 950 | 1050 | 1150 | 1250 | 1350 | 1450 | 1550 |
| FEET | 5 | 7 | 9 | 11 | 12 | 13 | 15 | 17 | 19 | 20 |
| METERS | 1,5 | 2,1 | 2,7 | 3,4 | 3,7 | 4 | 4,6 | 5,2 | 5,8 | 6,1 |

Figure NPSH required prior to using above table. DO NOT use as available Suction Lifts.
 3.00"/[76,2 MM] DIA. MAX. SPHERICAL SOLIDS

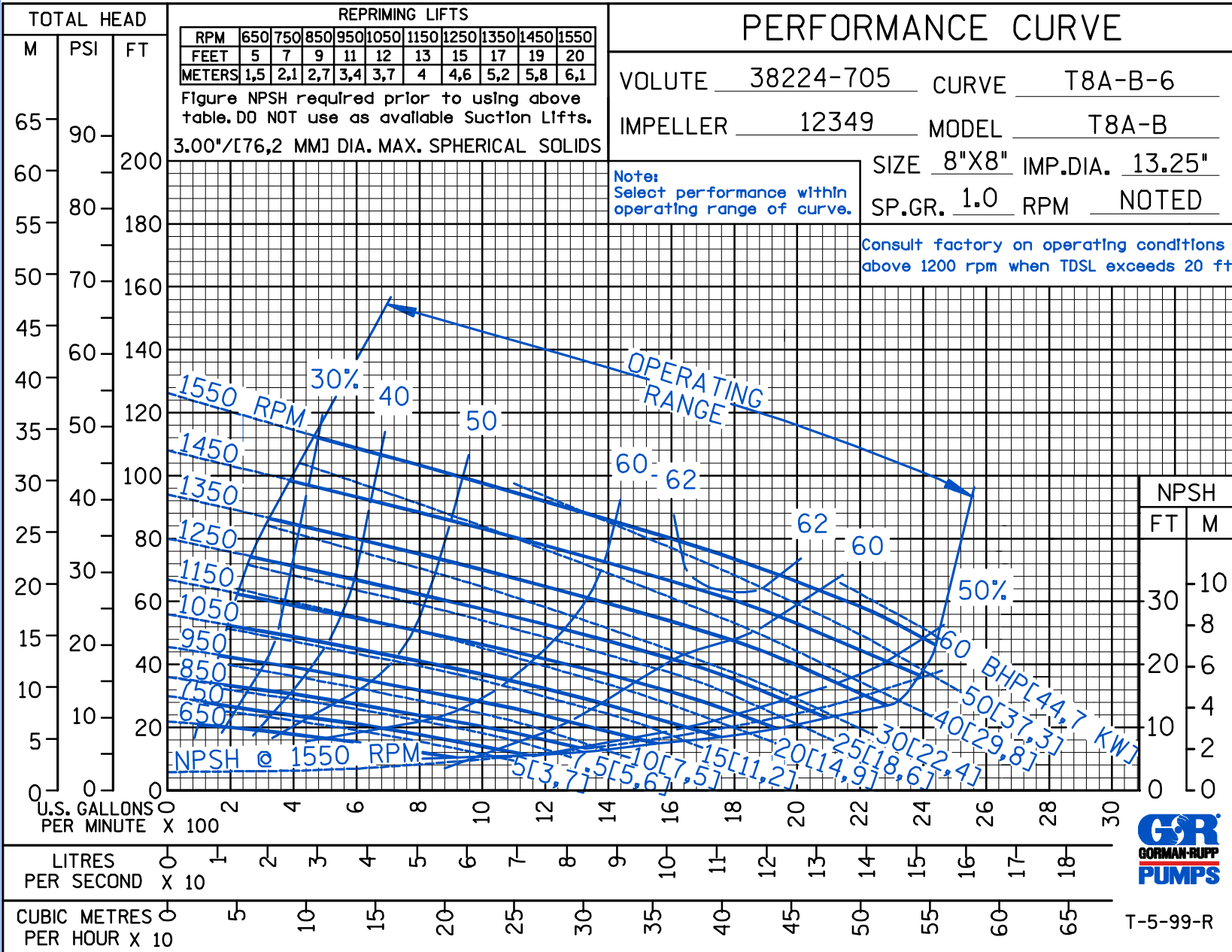

T-5-99-R



THE GORMAN-RUPP COMPANY • MANSFIELD, OHIO
 GORMAN-RUPP OF CANADA LIMITED • ST. THOMAS, ONTARIO, CANADA
 www.grpumps.com

Specifications Subject to Change Without Notice

Printed in U.S.A.



THE GORMAN-RUPP COMPANY • MANSFIELD, OHIO
 GORMAN-RUPP OF CANADA LIMITED • ST. THOMAS, ONTARIO, CANADA
 www.grpumps.com

© Copyright by the Gorman-Rupp Company 2009

Specifications Subject to Change Without Notice

Printed in U.S.A.

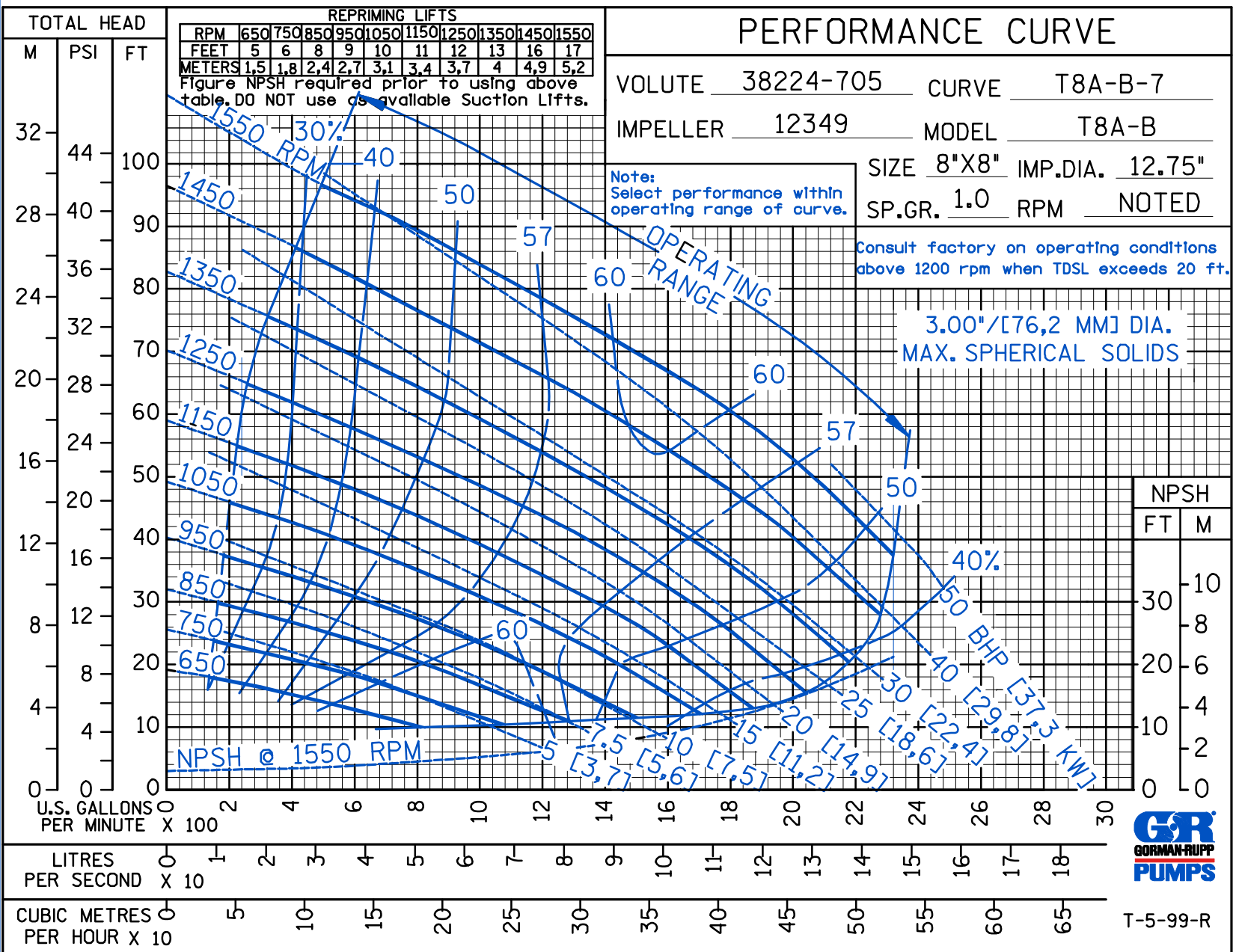

Curve Data

Sec. 55

PAGE 2351.7
 SEPTEMBER 2009



THE GORMAN-RUPP COMPANY • MANSFIELD, OHIO
 GORMAN-RUPP OF CANADA LIMITED • ST. THOMAS, ONTARIO, CANADA
 www.grpumps.com

© Copyright by the Gorman-Rupp Company 2009

Specifications Subject to Change Without Notice

Printed in U.S.A.

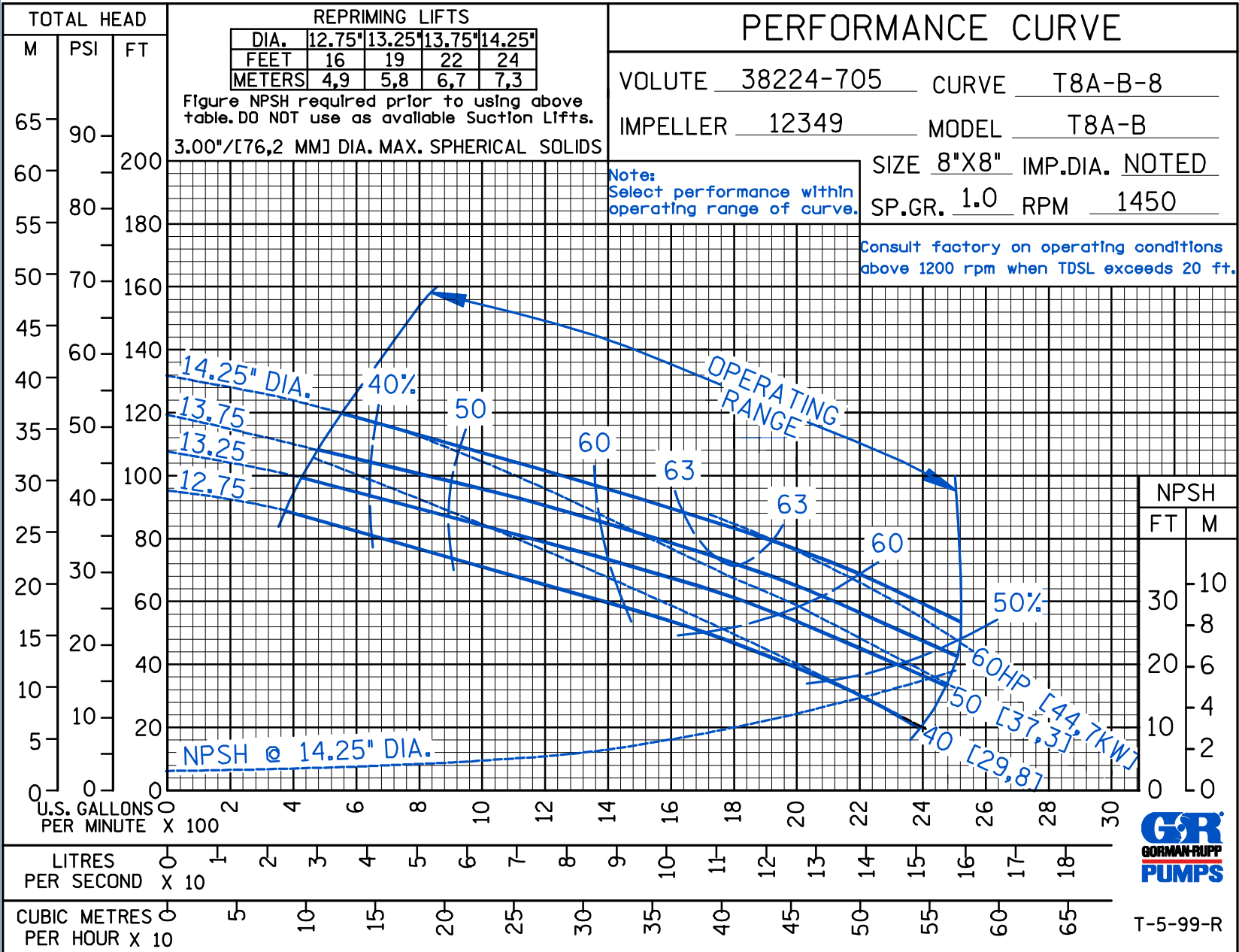

CDS

Curve Data

Sec. 55

PAGE 2351.8
SEPTEMBER 2009



T-5-99-R



THE GORMAN-RUPP COMPANY • MANSFIELD, OHIO

GORMAN-RUPP OF CANADA LIMITED • ST. THOMAS, ONTARIO, CANADA

www.grpumps.com

Specifications Subject to Change Without Notice

© Copyright by the Gorman-Rupp Company 2009

Printed in U.S.A.

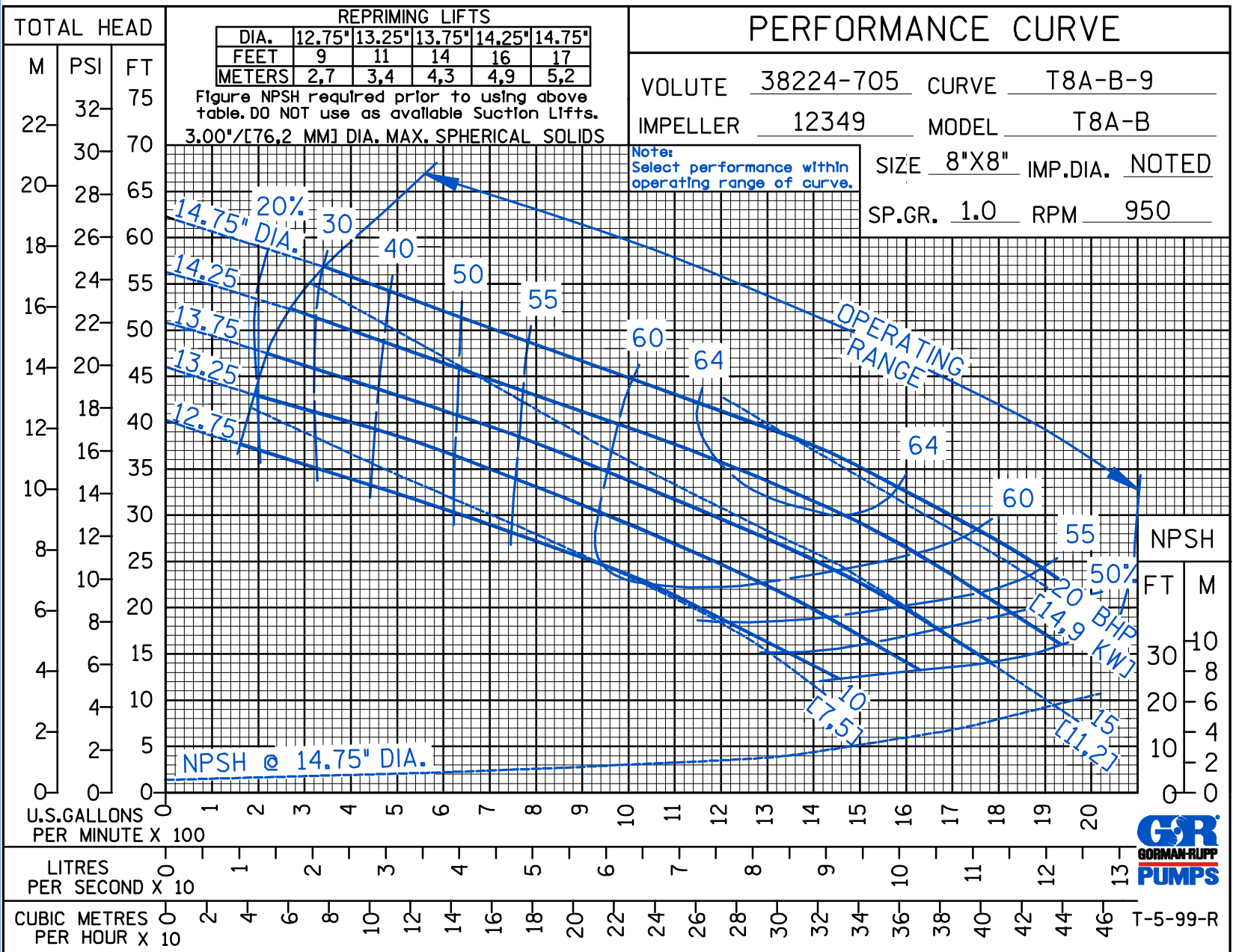

CDS

Curve Data

Sec. 55

PAGE 2351.9
SEPTEMBER 2009



THE GORMAN-RUPP COMPANY • MANSFIELD, OHIO
 GORMAN-RUPP OF CANADA LIMITED • ST. THOMAS, ONTARIO, CANADA
 www.grpumps.com

© Copyright by the Gorman-Rupp Company 2009

Specifications Subject to Change Without Notice

Printed in U.S.A.

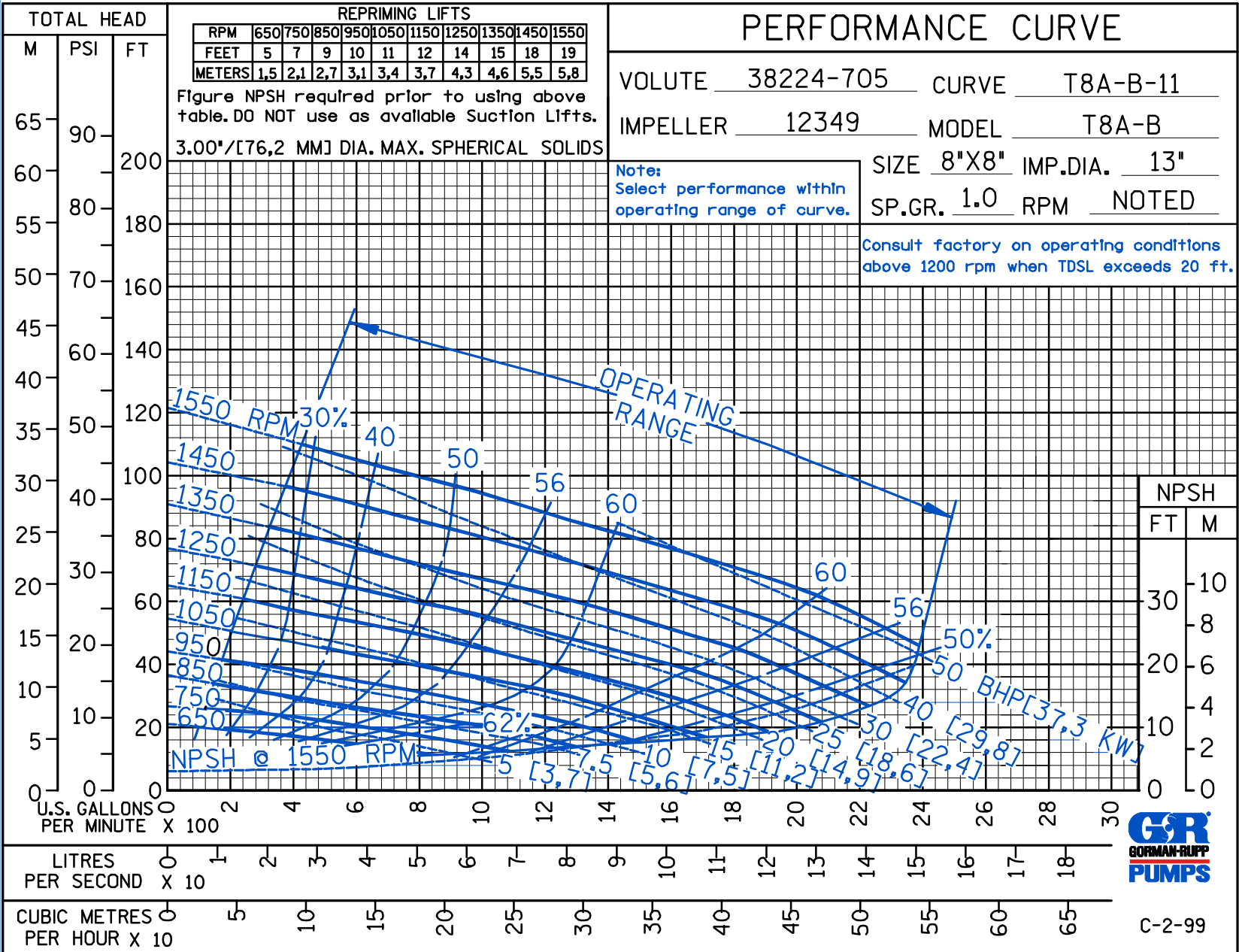

CDS

Curve Data

Sec. 55

PAGE 2351.10
 SEPTEMBER 2009

DS

PERFORMANCE CURVE

VOLUTE 38224-705 CURVE T8A-B-12
 IMPELLER 12349 MODEL T8A-B
 SIZE 8"X8" IMP.DIA. 14.75"
 SP.GR. 1.0 RPM NOTED

NOTE: See single pump curve for horsepower, efficiency, & NPSH

Consult factory on operating conditions above 1200 rpm when TDSL exceeds 20 ft.

2 PUMPS IN PARALLEL

3.00"/[76,2 MM] DIA. MAX. SPHERICAL SOLIDS CURVE FOR PARALLEL APPLICATION ONLY & SHOULD NOT BE USED FOR SINGLE PUMP PERFORMANCE

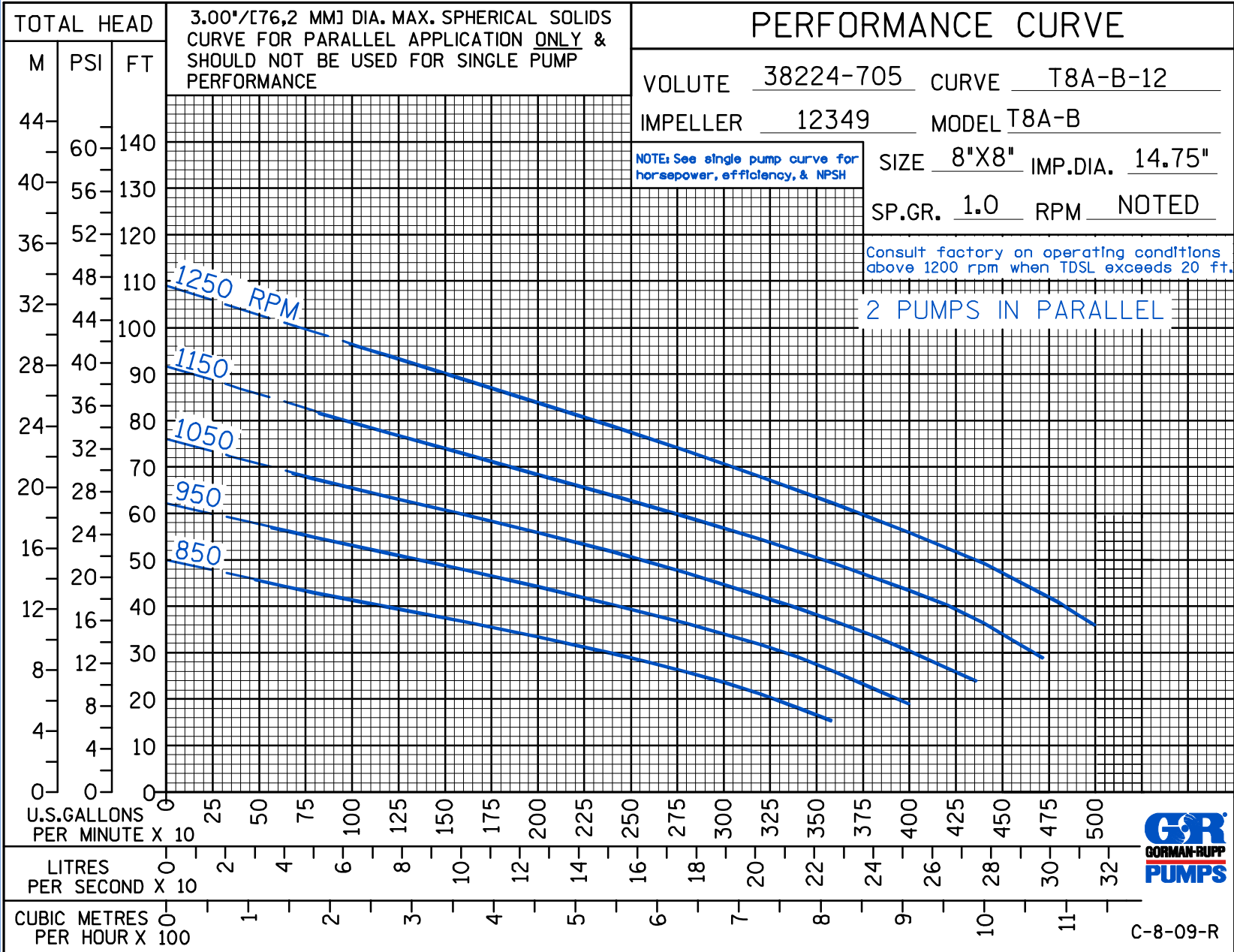

C-8-09-R



THE GORMAN-RUPP COMPANY • MANSFIELD, OHIO
 GORMAN-RUPP OF CANADA LIMITED • ST. THOMAS, ONTARIO, CANADA

www.grpumps.com
 Specifications Subject to Change Without Notice

DS

PERFORMANCE CURVE

VOLUTE 38224-705 CURVE T8A-B-13
 IMPELLER 12349 MODEL T8A-B
 SIZE 8"X8" IMP.DIA. 14.75"
 SP.GR. 1.0 RPM NOTED

Performance shown does not include any interconnecting piping

NOTE: Series operation is limited by the operating pressure & NPSH requirement of a single pump. See single pump curve for NPSH, EFF., & HP.

Consult factory on operating conditions above 1200 rpm when TDSL exceeds 20 ft.

2 PUMPS IN SERIES

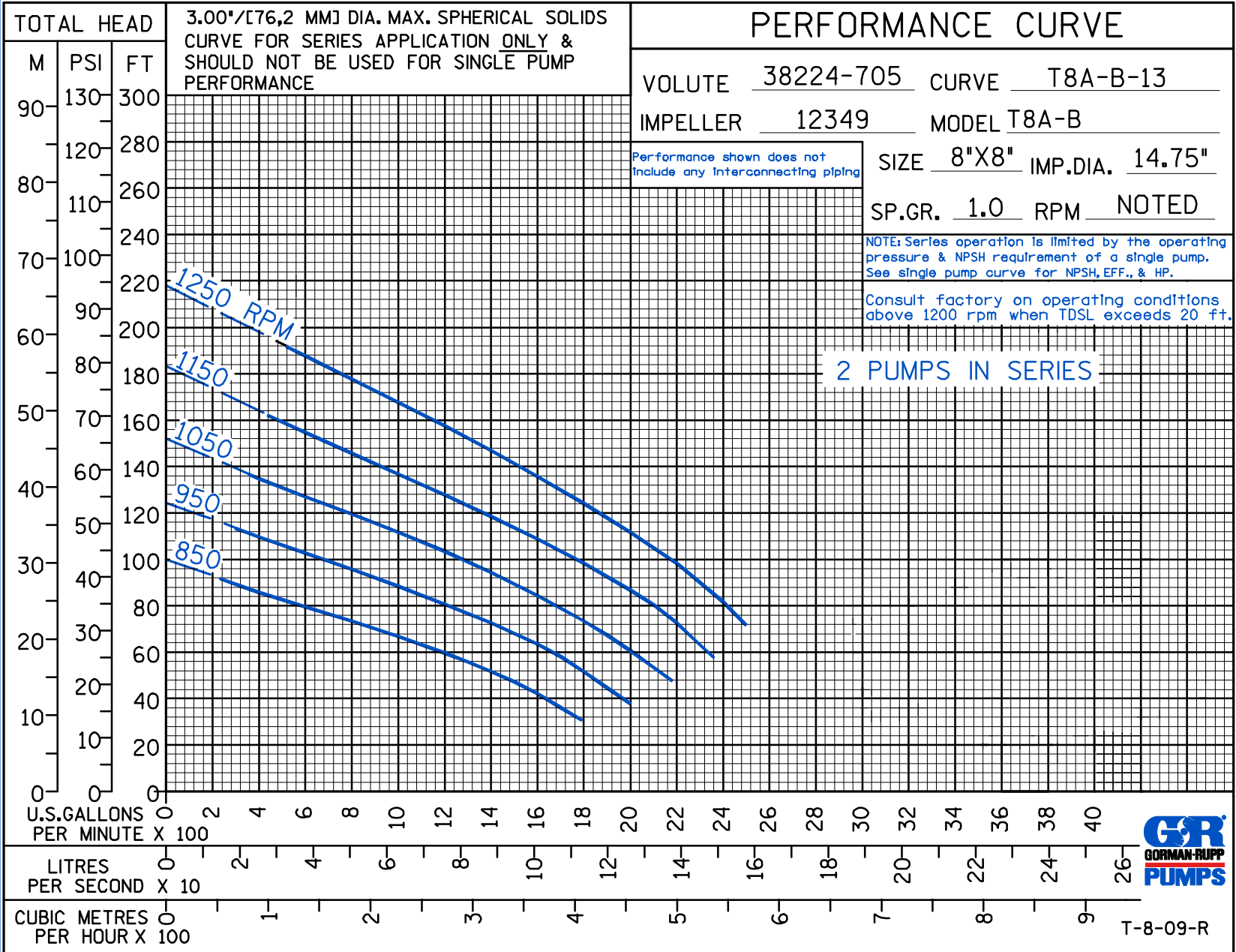

THE GORMAN-RUPP COMPANY • MANSFIELD, OHIO
 GORMAN-RUPP OF CANADA LIMITED • ST. THOMAS, ONTARIO, CANADA

www.grpumps.com
 Specifications Subject to Change Without Notice

Printed in U.S.A.

T-8-09-R