

# Self Priming Centrifugal Pump

*Super*  
**T SERIES**

**Model T10A65S-B**  
**Size 10" x 10"**



## PUMP SPECIFICATIONS

**Size:** 10" x 10" (254 mm x 254 mm) Flanged.

**Casing:** Stainless Steel CD4MCu.

Maximum Operating Pressure 99 psi (683 kPa).\*

**Semi-Open Type, Two Vane Impeller:** Stainless Steel CD4MCu.

Handles 3" (76,2 mm) Diameter Spherical Solids.

**Impeller Shaft:** Stainless Steel 17-4 PH.

**Replaceable Wear Plate:** Stainless Steel CD4MCu.

**Seal Plate:** Stainless Steel CD4MCu.

**Removable Clean-out Cover Plate:** Stainless Steel CD4MCu;  
9 lbs. (4 kg).

**Flap Valve:** Fluorocarbon (DuPont Viton® or Equivalent)  
w/Stainless Steel Reinforcing.

**Bearing Housing:** Stainless Steel CD4MCu.

**Seal Plate:** Stainless Steel CD4MCu.

**Radial and Thrust Bearings:** Open Double Row Ball.

**Bearing and Seal Cavity Lubrication:** SAE 30 Non-Detergent Oil.

**Suction Flange:** Stainless Steel CD4MCu.

**Suction Head:** Stainless Steel CD4MCu.

**Gaskets:** Fluorocarbon (DuPont Viton® or Equivalent), and PTFE.

**O-Rings:** Fluorocarbon (DuPont Viton® or Equivalent).

**Hardware:** Stainless Steel 316.

**Pressure Relief Valve:** Stainless Steel 316.

**Bearing and Seal Cavity Oil Level Sight Gauges.**

**Optional Equipment:** Metal Bellows Seal. Automatic Air

Release Valve. High Pump Temperature Shutdown

Kit. 120V/240V Casing Heater. Self Cleaning Wear Plate.

Stainless Steel CD4MCu Spool Flanges:

10" ASA Discharge.

250 mm DIN 2527 (PN 16) Suction and Discharge.

*\*Consult Factory for Applications Exceeding Maximum  
Pressure and/or Temperature Indicated.*



Shown with Optional Discharge Spool Flange (Suction/Discharge Spool Flanges Available in ASA or DIN Standard Sizes).

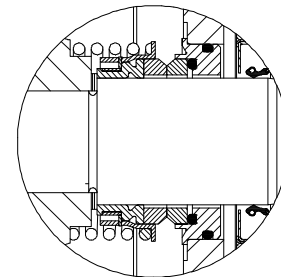
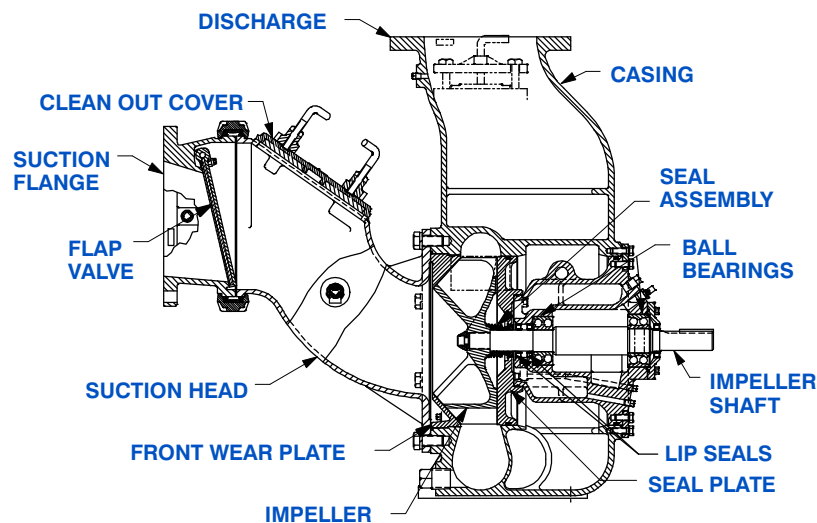

## SEAL DETAIL

Mechanical, Oil-Lubricated, Double Floating, Self-Aligning. Silicon Carbide Rotating and Stationary Faces. Stainless Steel 316 Stationary Seat. Fluorocarbon Elastomers (DuPont Viton® or Equivalent). Stainless Steel 18-8 Cage and Spring. Maximum Temperature of Liquid Pumped, 160°F (71°C).\*

**GR**  
GORMAN-RUPP  
PUMPS

**GORMAN-RUPP PUMPS**

www.grpumps.com

Specifications Subject to Change Without Notice

Printed in U.S.A.

**Specification Data**

SECTION 55, PAGE 2430

**APPROXIMATE DIMENSIONS and WEIGHTS**

**NET WEIGHT: 1504 LBS. (682 KG.)\***  
**SHIPPING WEIGHT: 1562 LBS. (708 KG.)\***  
**EXPORT CRATE: 53.0 CU. FT. (1,5 CU. M.)**  
**\*ADD 79 LBS. (35,8 KG.) W/DISCH SPOOL FLANGE**

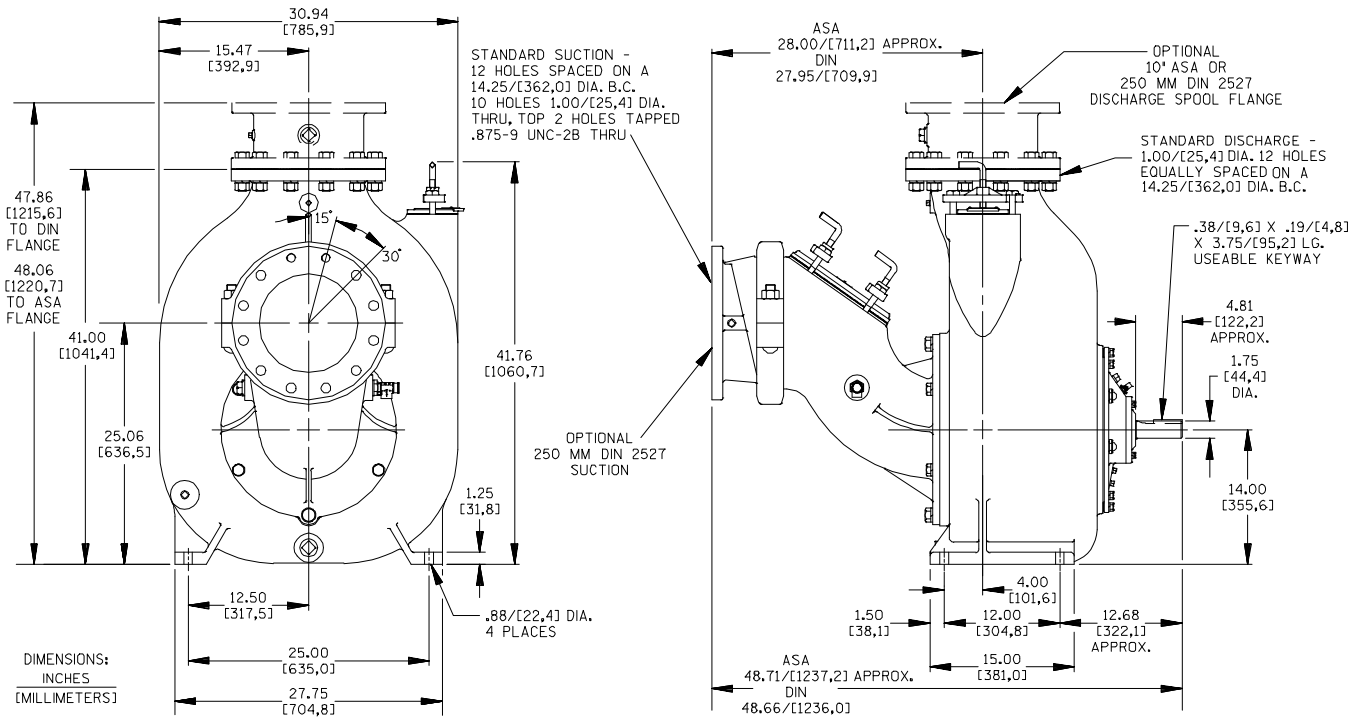

**OPTIONAL ASA OR DIN STANDARD SPOOL FLANGES AVAILABLE**

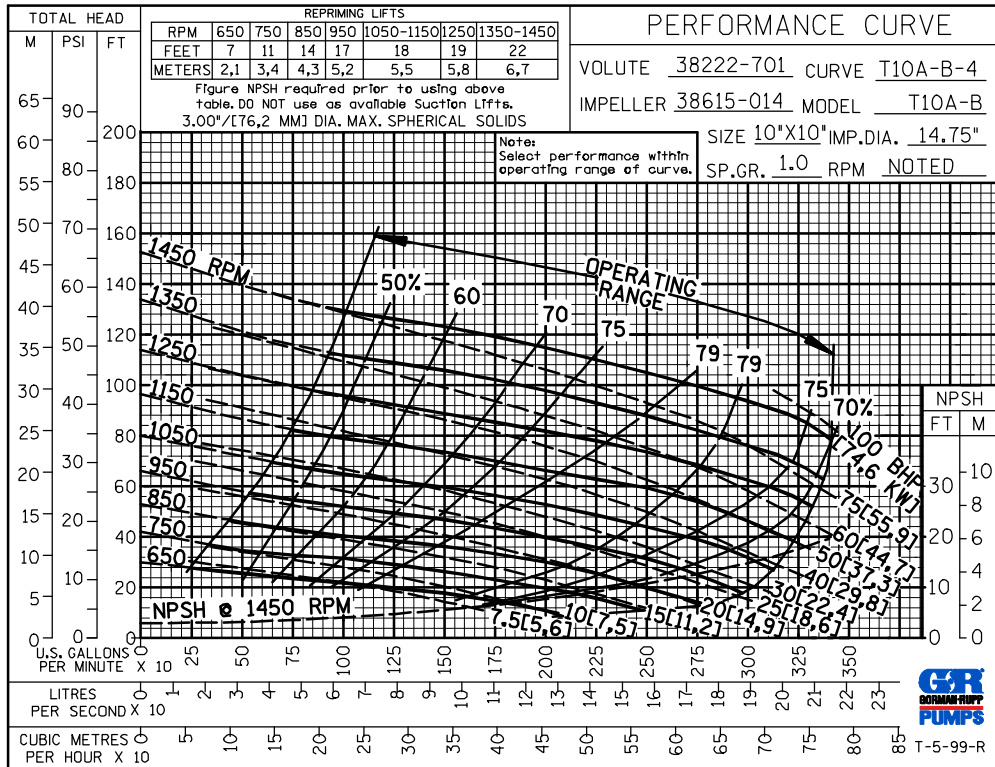

**GORMAN-RUPP PUMPS**

www.grpumps.com

Specifications Subject to Change Without Notice

Printed in U.S.A.