

CDS

# Self Priming Centrifugal Pump

**Super  
T SERIES**

VARIOUS PATENTS APPLY

**Model T10A71S-B****Size 10" x 10"****PUMP SPECIFICATIONS****Size:** 10" x 10" (254 mm x 254 mm) Flanged.**Casing:** Gray Iron 30.

Maximum Operating Pressure 99 psi (683 kPa).\*

**Semi-Open Type, Two Vane Impeller:** G-R Hard Iron.

Handles 3" (76.2 mm) Diameter Spherical Solids.

**Impeller Shaft:** Stainless Steel 17-4 PH.**Shaft Sleeve:** Alloy Steel 4130.**Replaceable Front Wear Plate:** Hardened Alloy Steel.**Replaceable Rear Wear Plate:** Hardened Alloy Steel.**Removable Clean-out Cover Plate:** Gray Iron 30; 9 lbs. (4 kg).**Flap Valve:** Neoprene w/Steel Reinforcing.**Bearing Housing:** Gray Iron 30.**Seal Plate:** G-R Hard Iron.**Radial and Thrust Bearings:** Open Double Row Ball.**Bearing and Seal Cavity Lubrication:** SAE 30

Non-Detergent Oil.

**Suction Flange:** 125# Gray Iron 30.**Suction Head:** Gray Iron 30.**Gaskets:** Buna-N, PTFE, Cork, and Rubber.**O-Rings:** Buna-N.**Hardware:** Standard Plated Steel.**Brass Pressure Relief Valve.****Bearing and Seal Cavity Oil Level Sight Gauges.****Optional Equipment:** Metal Bellows Seal. Automatic Air Release Valve. High Pump Temperature Shutdown Kit. 120V/240V Casing Heater. Continuous Vane GR Hard Iron Impeller w/Self-Cleaning GR Hard Iron Wear Plate.

Gray Iron 30 Spool Flanges:

10" ASA Discharge.

250 mm DIN 2527 (PN16) Suction and Discharge

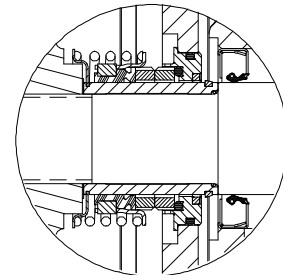
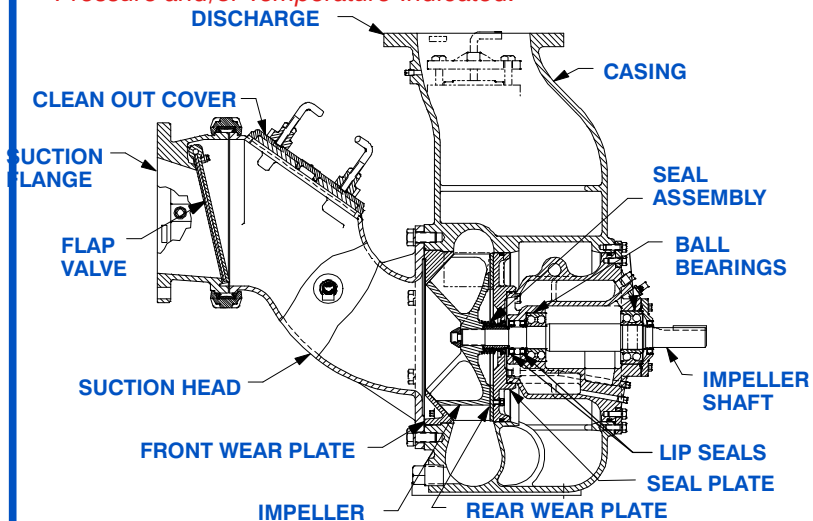
**(Specify Model T10A71S-B /FM).***\*Consult Factory for Applications Exceeding Maximum Pressure and/or Temperature Indicated.***Shown with Optional Discharge Spool Flange (Suction/Discharge Spool Flanges Available in ASA or DIN Standard Sizes).****SEAL SPECIFICATIONS**

Cartridge Type, Mechanical, Oil-Lubricated, Double Floating, Self-Aligning. Silicon Carbide Rotating and Stationary Faces. Stainless Steel 316 Stationary Seat. Stainless Steel 18-8 Cage and Spring. Maximum Temperature of Liquid Pumped, 160°F (71°C).\*

**THE GORMAN-RUPP COMPANY • MANSFIELD, OHIO**

GORMAN-RUPP OF CANADA LIMITED • ST. THOMAS, ONTARIO, CANADA

www.grpumps.com

Specifications Subject to Change Without Notice

Printed in U.S.A.

**Specification Data**

**NET WEIGHT:** 1460 LBS. (662 KG.)\*  
**SHIPPING WEIGHT:** 1610 LBS. (730 KG.)\*  
**EXPORT CRATE:** 70.3 CU. FT. (2 CU. M.)  
**\*ADD 71 LBS. (32,2 KG.) W/DISCH SPOOL FLANGE**

**SECTION 55, PAGE 2440**

**APPROXIMATE DIMENSIONS and WEIGHTS**

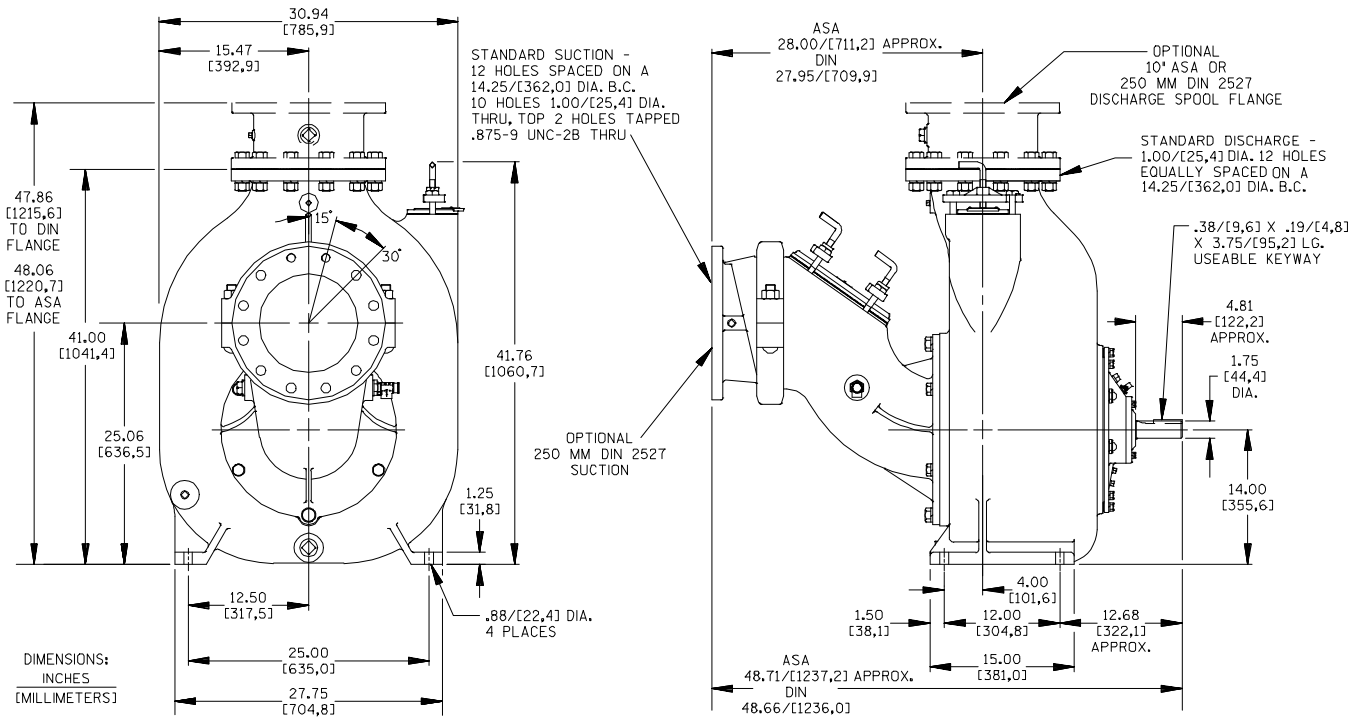

**OPTIONAL ASA OR DIN STANDARD SPOOL FLANGES AVAILABLE**

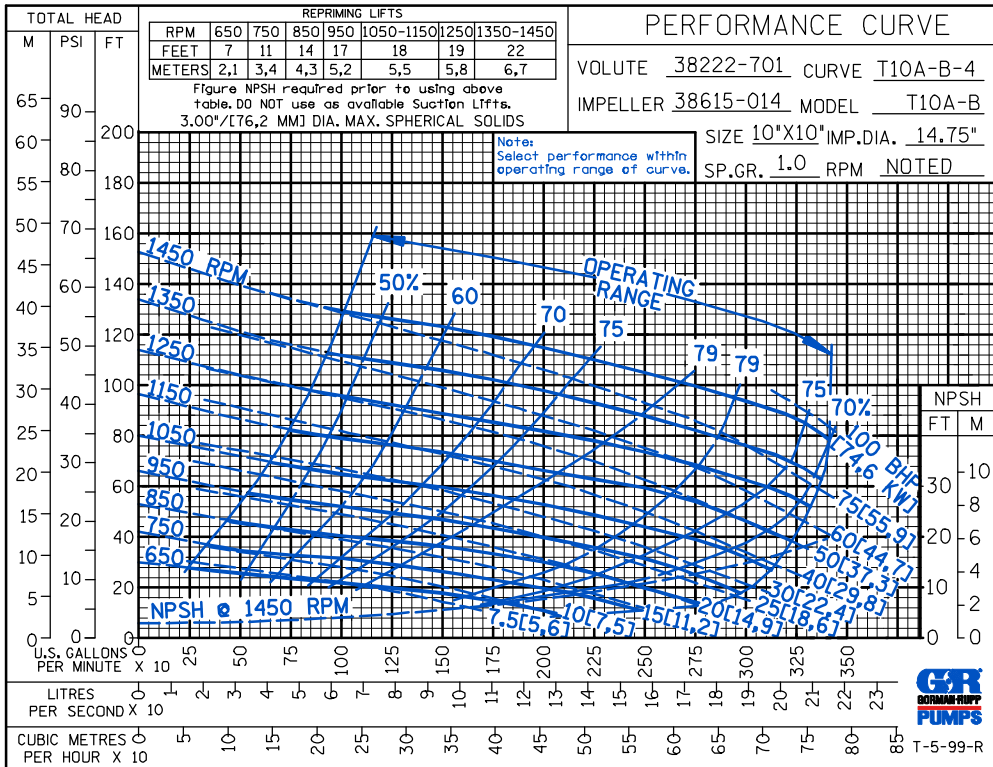

**THE GORMAN-RUPP COMPANY • MANSFIELD, OHIO**

GORMAN-RUPP OF CANADA LIMITED • ST. THOMAS, ONTARIO, CANADA

Specifications Subject to Change Without Notice

Printed in U.S.A.



**THE GORMAN-RUPP COMPANY • MANSFIELD, OHIO**  
 GORMAN-RUPP OF CANADA LIMITED • ST. THOMAS, ONTARIO, CANADA  
 www.grpumps.com

© Copyright by the Gorman-Rupp Company 2009

Specifications Subject to Change Without Notice

Printed in U.S.A.

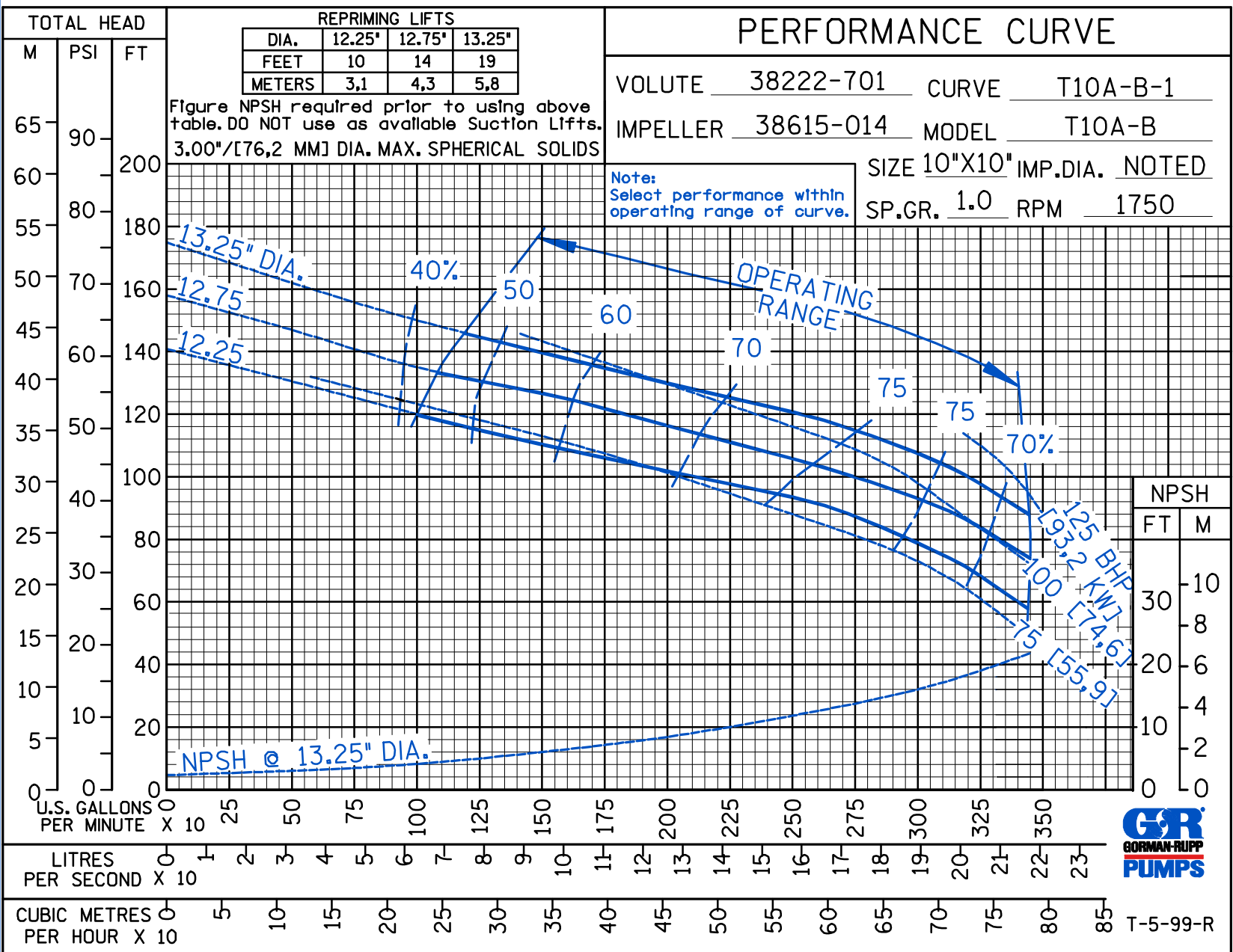

Curve Data

Sec. 55

PAGE 2451.1  
JUNE 2009



T-5-99-R



**THE GORMAN-RUPP COMPANY • MANSFIELD, OHIO**  
 GORMAN-RUPP OF CANADA LIMITED • ST. THOMAS, ONTARIO, CANADA  
 www.grpumps.com

© Copyright by the Gorman-Rupp Company 2009

Specifications Subject to Change Without Notice

Printed in U.S.A.

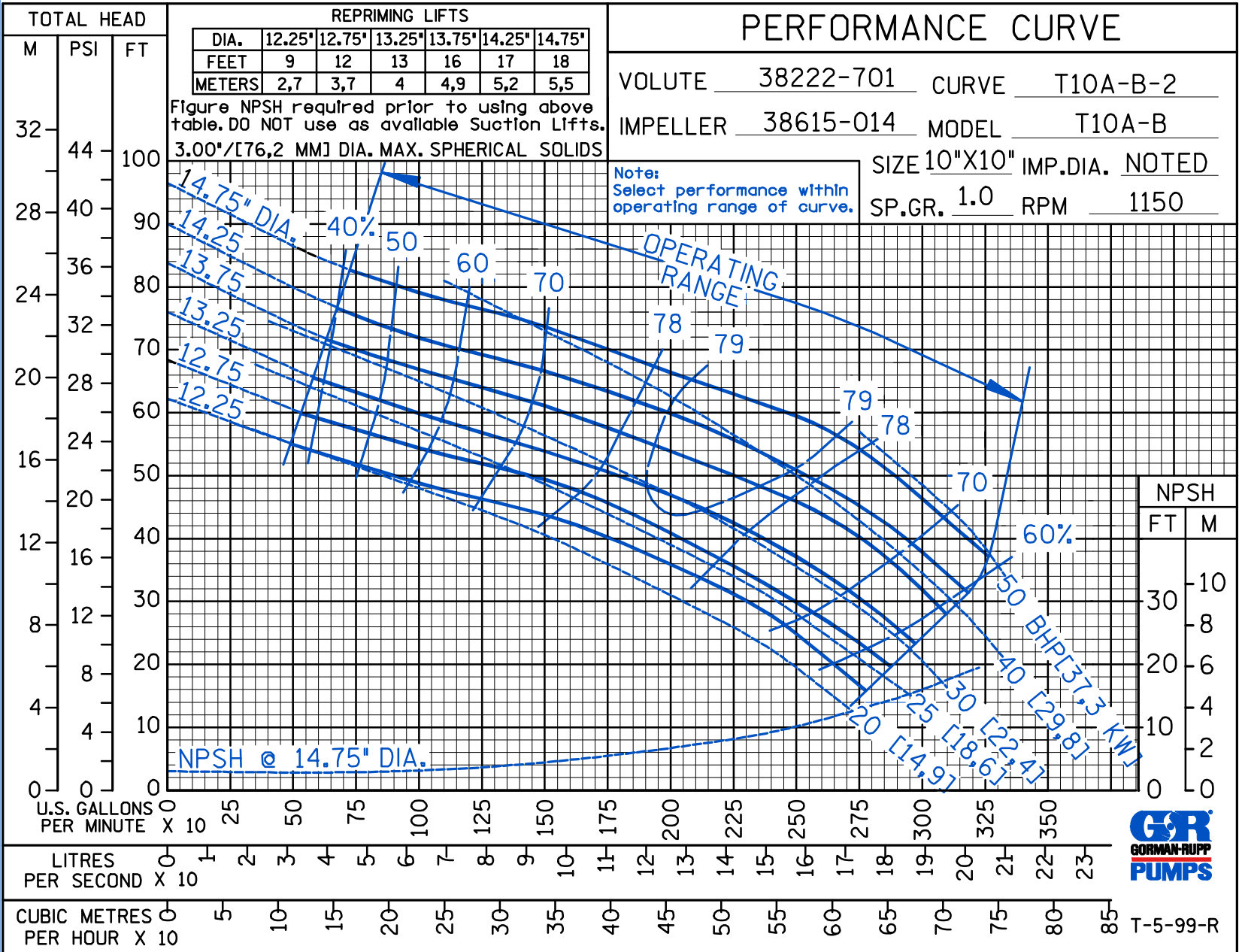

CDS

Curve Data

Sec. 55

PAGE 2451.2  
 JUNE 2009



T-5-99-R



THE GORMAN-RUPP COMPANY • MANSFIELD, OHIO  
 GORMAN-RUPP OF CANADA LIMITED • ST. THOMAS, ONTARIO, CANADA  
 www.grpumps.com

© Copyright by the Gorman-Rupp Company 2009

Specifications Subject to Change Without Notice

Printed in U.S.A.

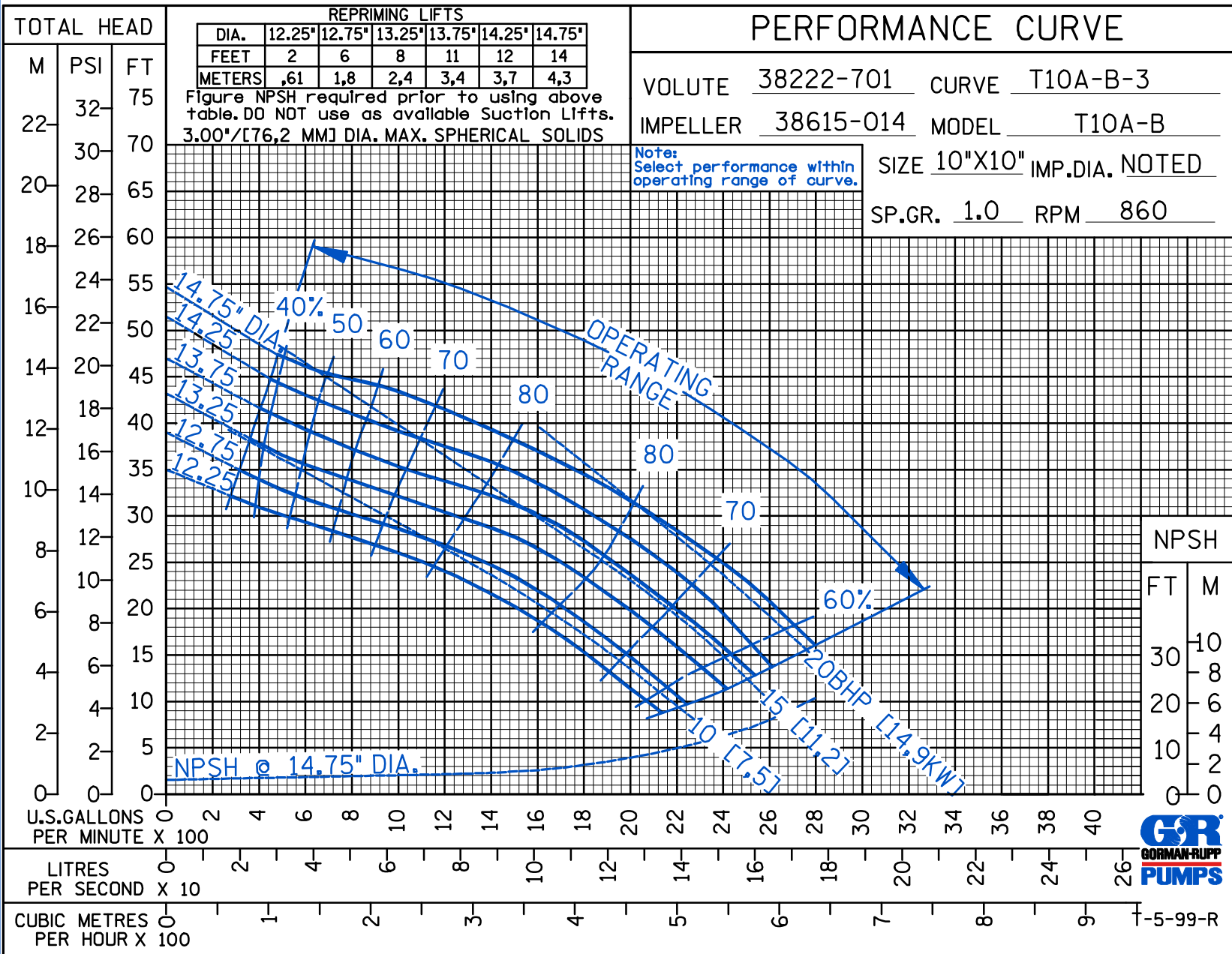

CDS

Curve Data

Sec. 55

PAGE 2451.3  
 JUNE 2009



CDS

PERFORMANCE CURVE

VOLUTE 38222-701 CURVE T10A-B-4  
 IMPELLER 38615-014 MODEL T10A-B  
 SIZE 10"X10" IMP.DIA. 14.75"  
 SP.GR. 1.0 RPM NOTED

REPRIMING LIFTS							
RPM	650	750	850	950	1050-1150	1250	1350-1450
FEET	7	11	14	17	18	19	22
METERS	2,1	3,4	4,3	5,2	5,5	5,8	6,7

Figure NPSH required prior to using above table. DO NOT use as available Suction Lifts.  
 3.00"/[76,2 MM] DIA. MAX. SPHERICAL SOLIDS

Note:  
 Select performance within operating range of curve.

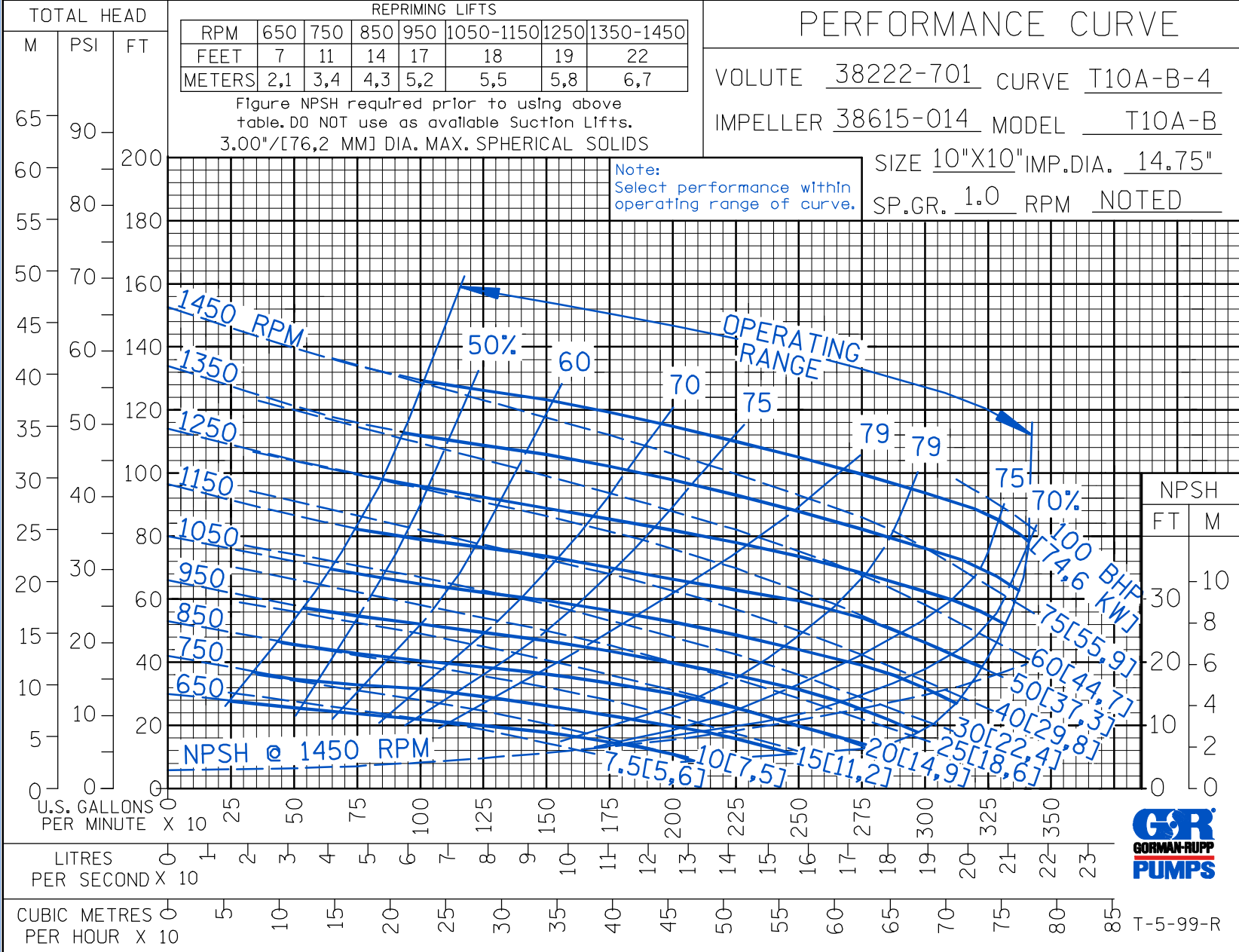

**THE GORMAN-RUPP COMPANY • MANSFIELD, OHIO**  
 GORMAN-RUPP OF CANADA LIMITED • ST. THOMAS, ONTARIO, CANADA

www.grpumps.com  
 Specifications Subject to Change Without Notice

Printed in U.S.A.

T-5-99-R



THE GORMAN-RUPP COMPANY • MANSFIELD, OHIO

GORMAN-RUPP OF CANADA LIMITED • ST. THOMAS, ONTARIO, CANADA

www.grpumps.com

Specifications Subject to Change Without Notice

Printed in U.S.A.

© Copyright by the Gorman-Rupp Company 2009

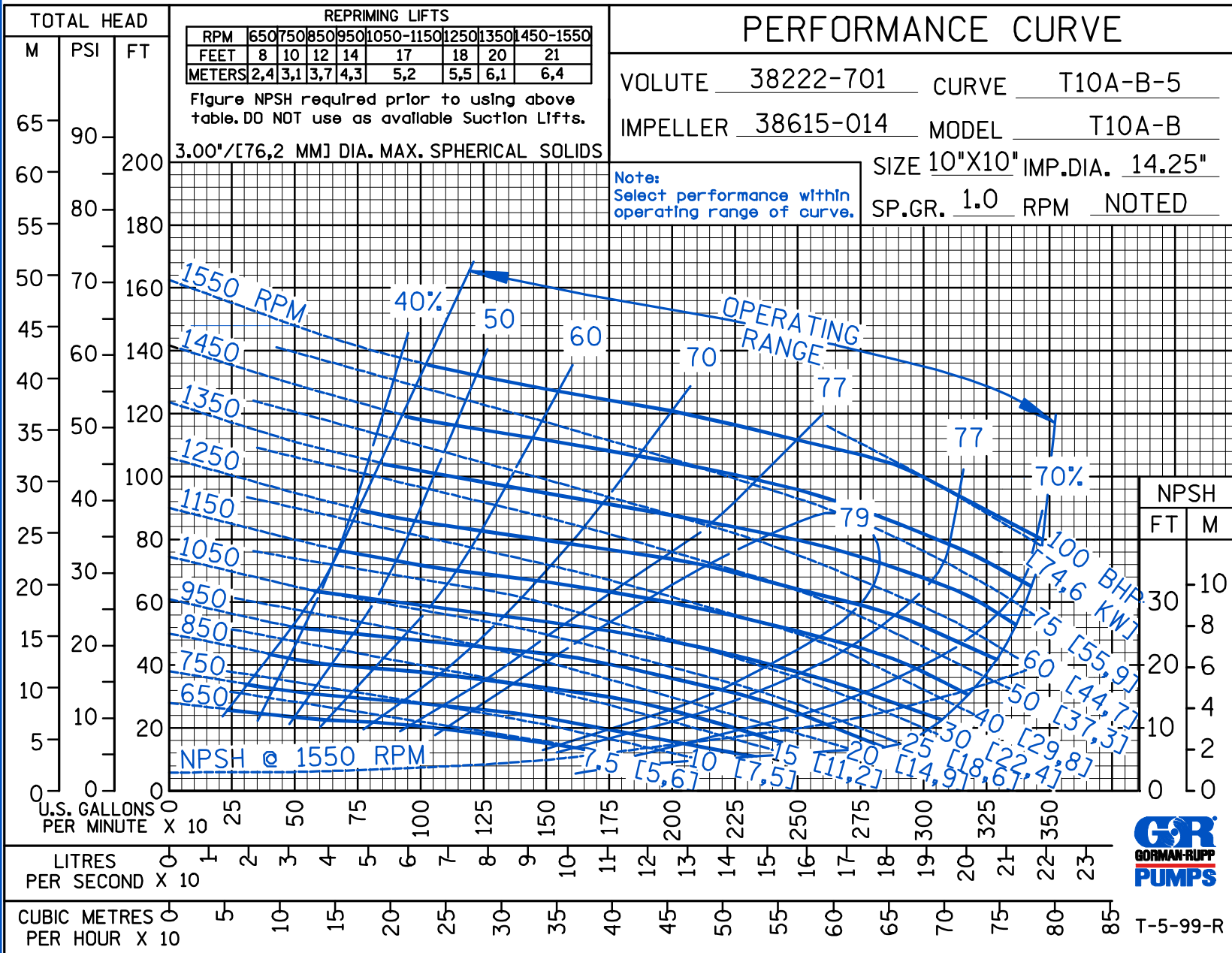

Curve Data

Sec. 55

PAGE 2451.5  
JUNE 2009



**THE GORMAN-RUPP COMPANY • MANSFIELD, OHIO**  
 GORMAN-RUPP OF CANADA LIMITED • ST. THOMAS, ONTARIO, CANADA  
 www.grpmumps.com

© Copyright by the Gorman-Rupp Company 2009

Specifications Subject to Change Without Notice

Printed in U.S.A.

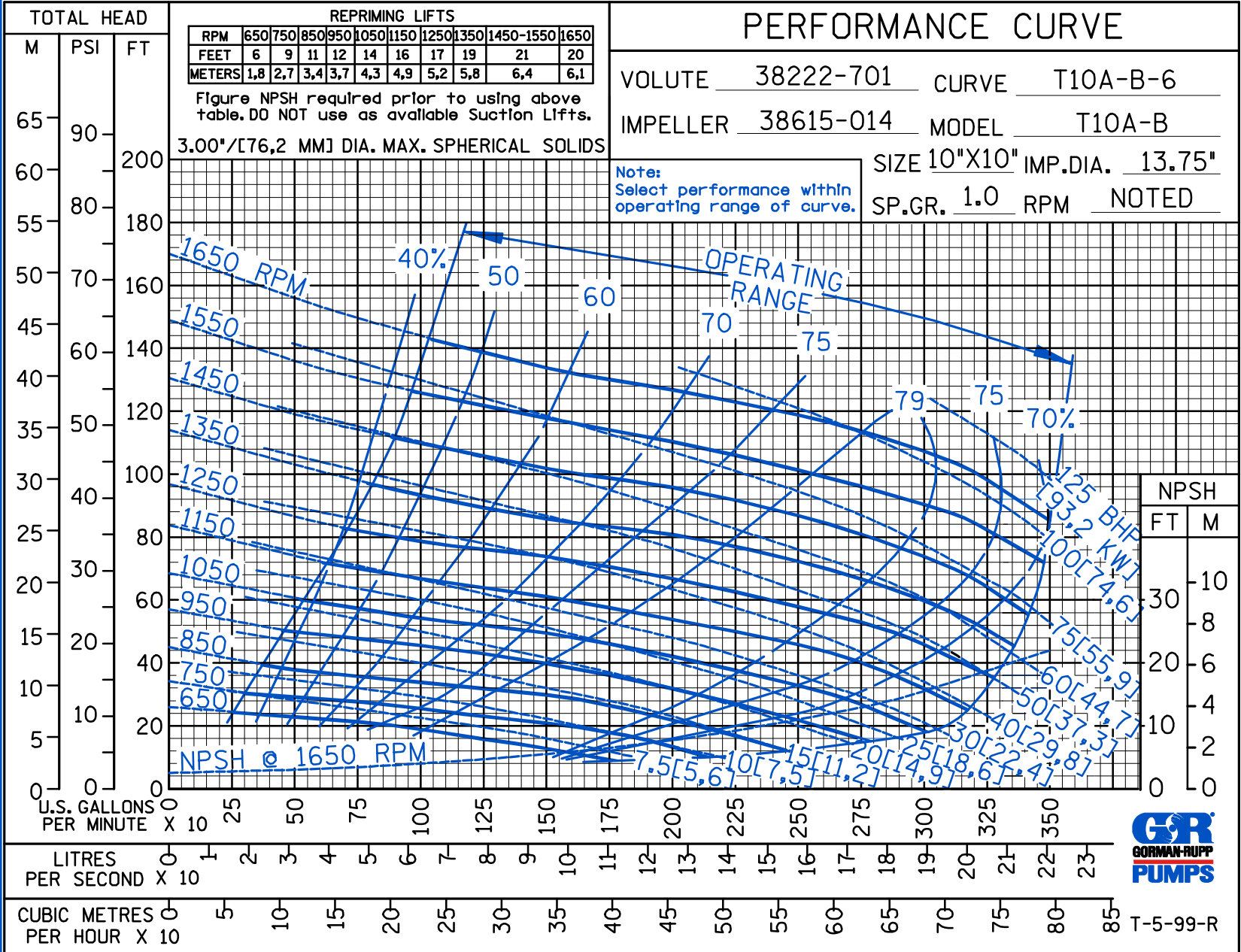

CDS

Curve Data

Sec. 55

PAGE 2451.6  
JUNE 2009





THE GORMAN-RUPP COMPANY • MANSFIELD, OHIO

GORMAN-RUPP OF CANADA LIMITED • ST. THOMAS, ONTARIO, CANADA

www.grpumps.com

Specifications Subject to Change Without Notice

Printed in U.S.A.

© Copyright by the Gorman-Rupp Company 2009

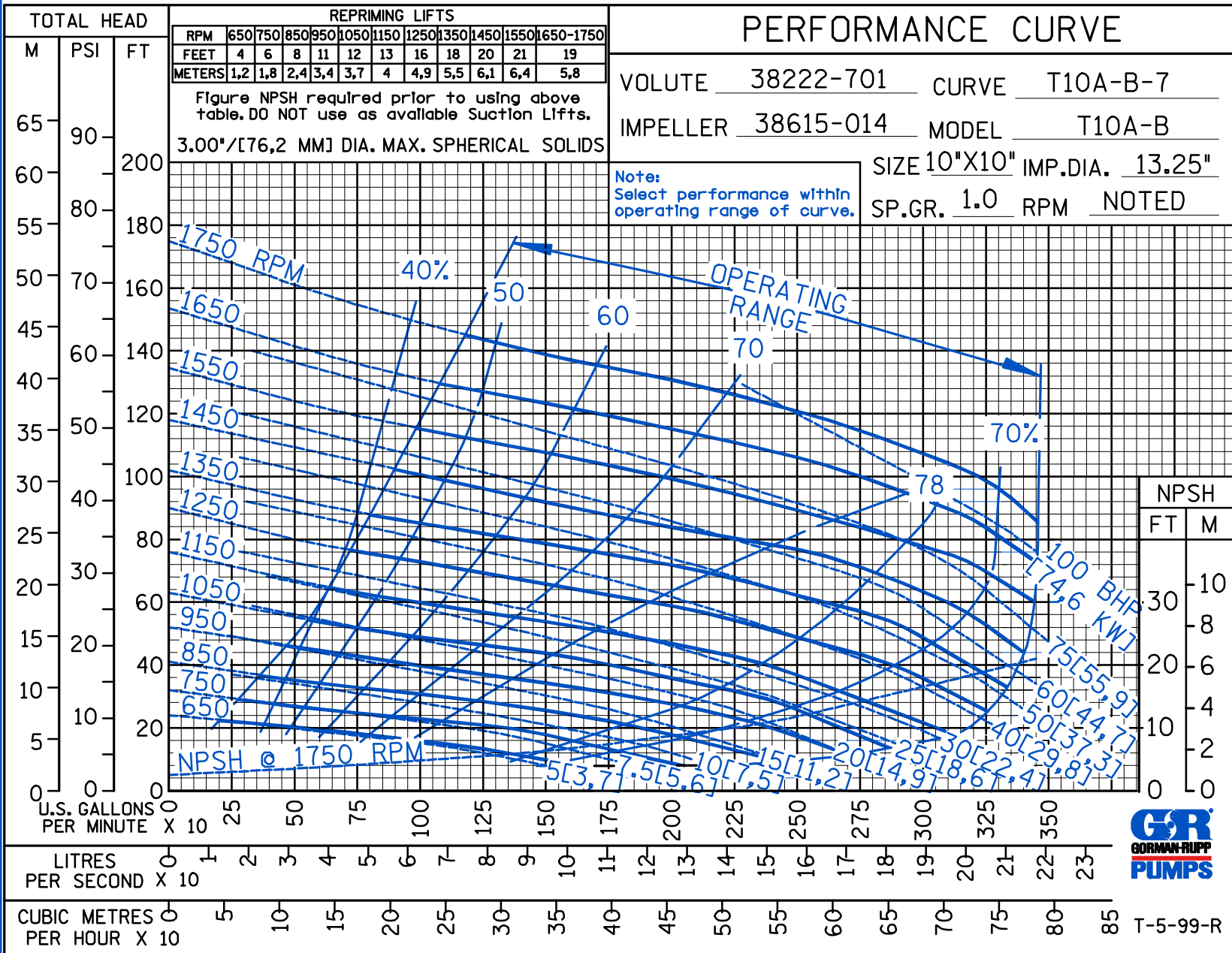

Curve Data

Sec. 55

PAGE 2451.7  
JUNE 2009

CDS



**THE GORMAN-RUPP COMPANY • MANSFIELD, OHIO**  
 GORMAN-RUPP OF CANADA LIMITED • ST. THOMAS, ONTARIO, CANADA  
 www.grpmumps.com

© Copyright by the Gorman-Rupp Company 2009

Specifications Subject to Change Without Notice

Printed in U.S.A.

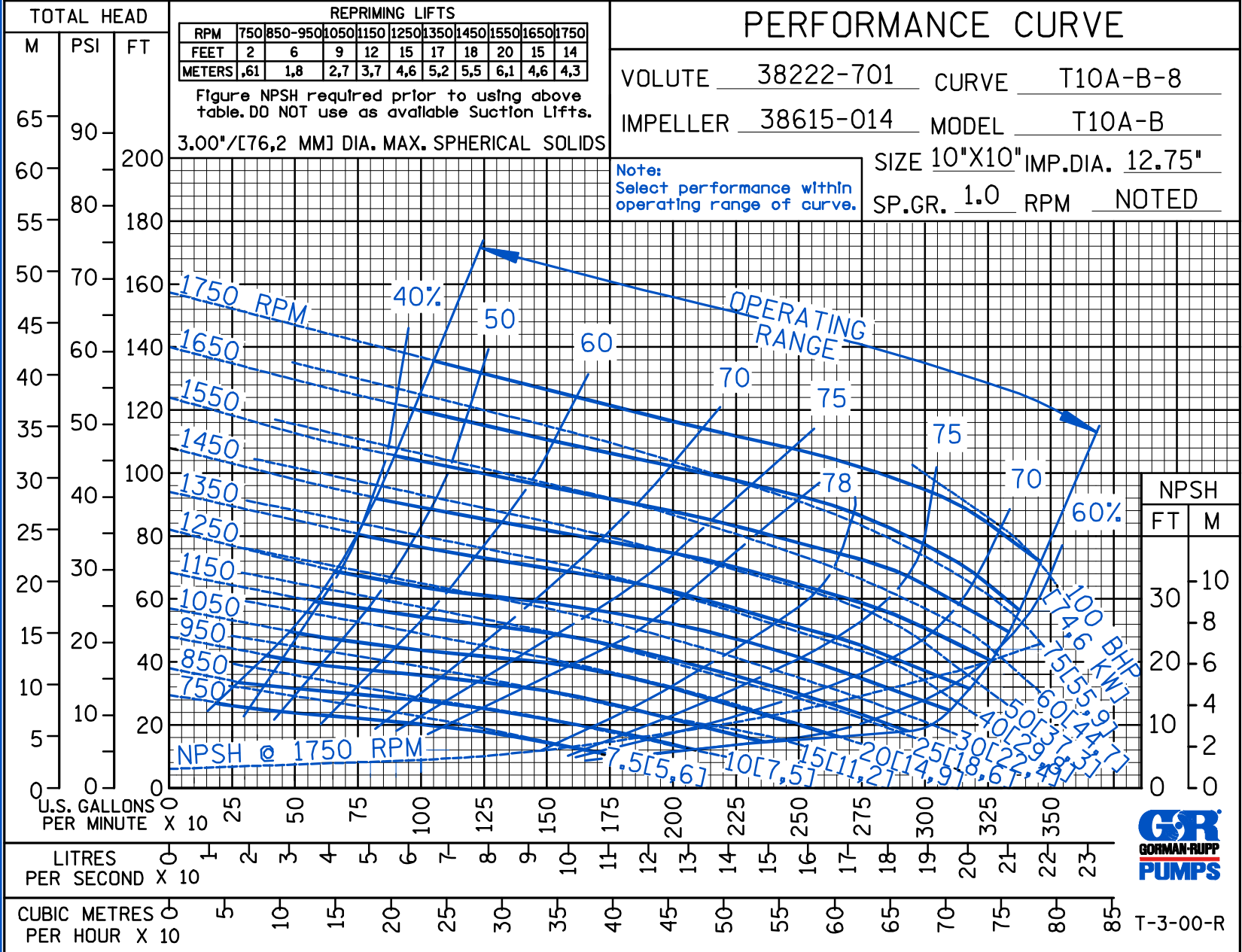

CDS

Curve Data

Sec. 55

PAGE 2451.8  
JUNE 2009



THE GORMAN-RUPP COMPANY • MANSFIELD, OHIO  
 GORMAN-RUPP OF CANADA LIMITED • ST. THOMAS, ONTARIO, CANADA  
 www.grpumps.com

© Copyright by the Gorman-Rupp Company 2009

Specifications Subject to Change Without Notice

Printed in U.S.A.

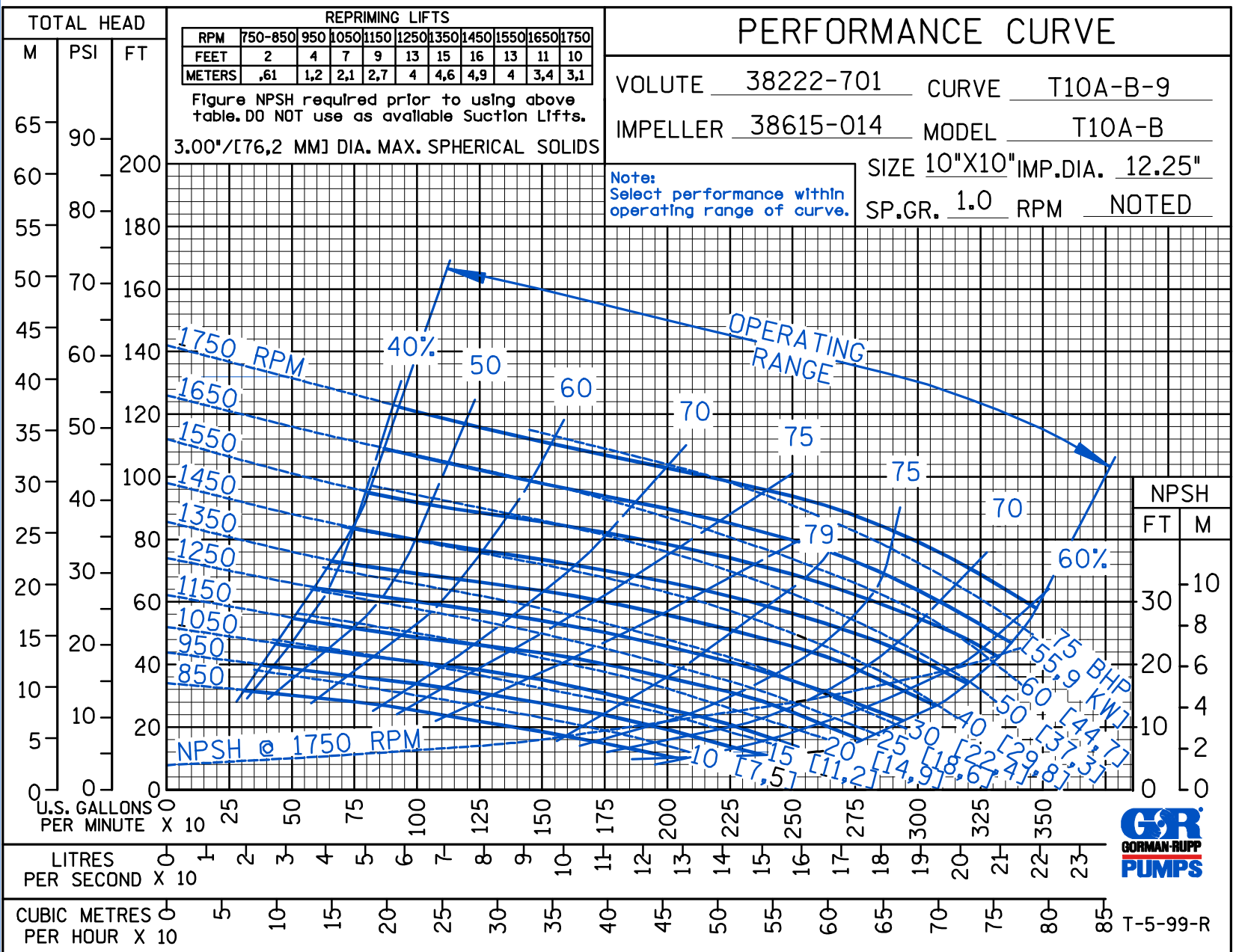

CDS

Curve Data

Sec. 55

PAGE 2451.9  
JUNE 2009



**THE GORMAN-RUPP COMPANY • MANSFIELD, OHIO**  
 GORMAN-RUPP OF CANADA LIMITED • ST. THOMAS, ONTARIO, CANADA  
 www.grpumps.com

© Copyright by the Gorman-Rupp Company 2009

Specifications Subject to Change Without Notice

Printed in U.S.A.

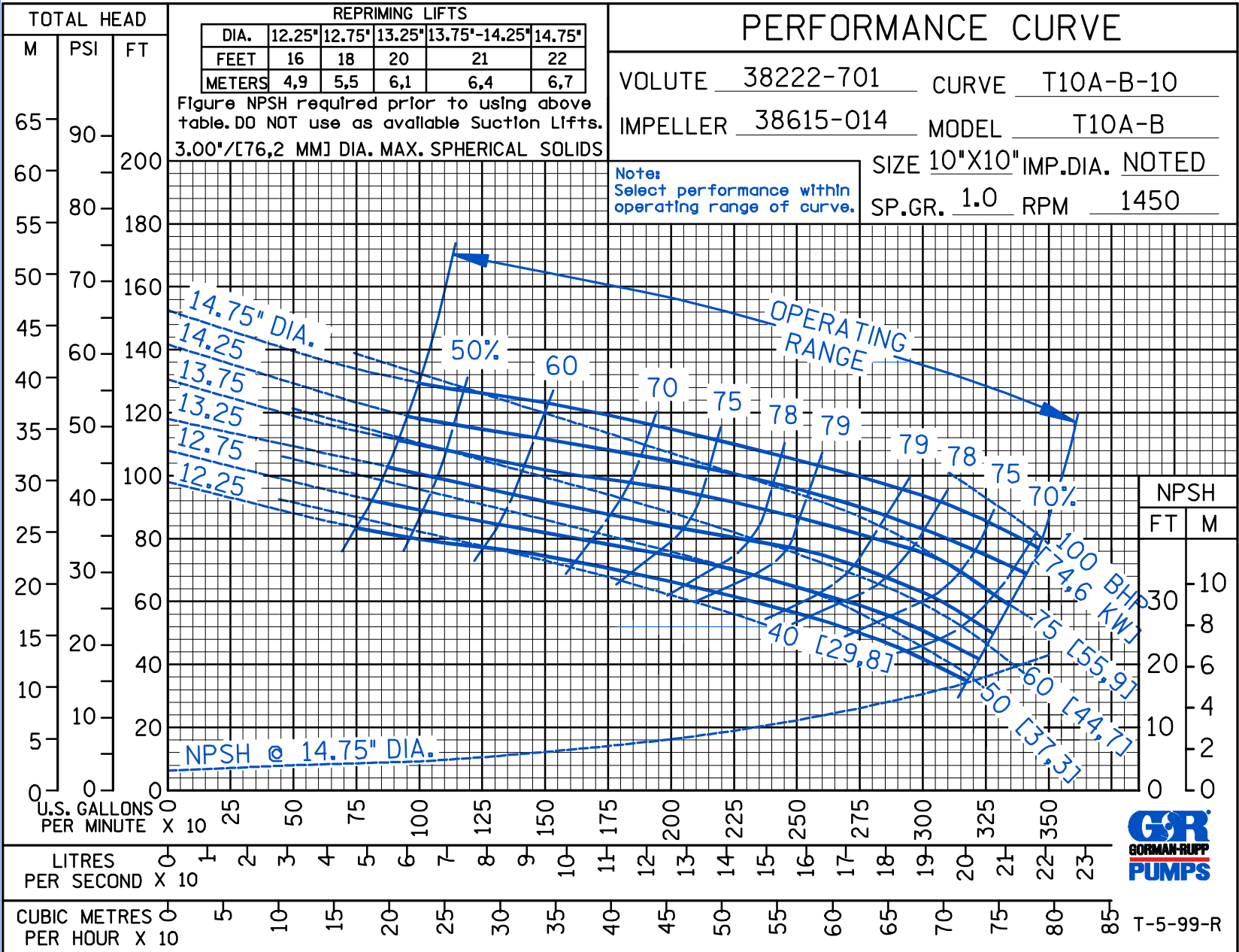

CDS

Curve Data

Sec. 55

PAGE 2451.10  
 JUNE 2009



T-5-99-R



THE GORMAN-RUPP COMPANY • MANSFIELD, OHIO

GORMAN-RUPP OF CANADA LIMITED • ST. THOMAS, ONTARIO, CANADA

www.grpumps.com

Specifications Subject to Change Without Notice

© Copyright by the Gorman-Rupp Company 2009

Printed in U.S.A.

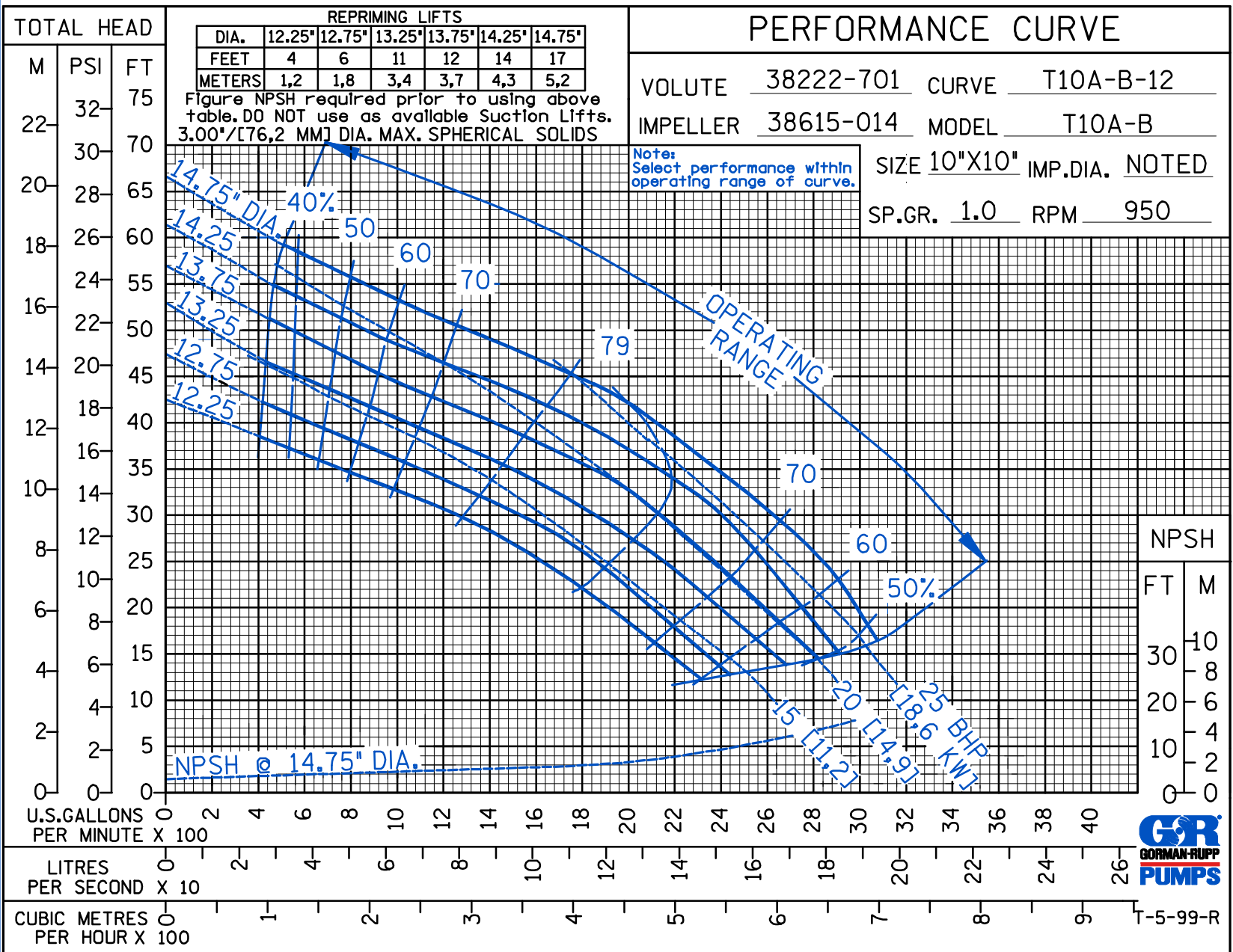

CDS

Curve Data

Sec. 55

PAGE 2451.11  
JUNE 2009



T-5-99-R



DS

# PERFORMANCE CURVE

VOLUTE 38222-701 CURVE T10A-B-14  
 IMPELLER 38615-014 MODEL T10A-B  
 SIZE 10"X10" IMP.DIA. 14.75"  
 SP.GR. 1.0 RPM NOTED

NOTE: See single pump curve for horsepower, efficiency, & NPSH

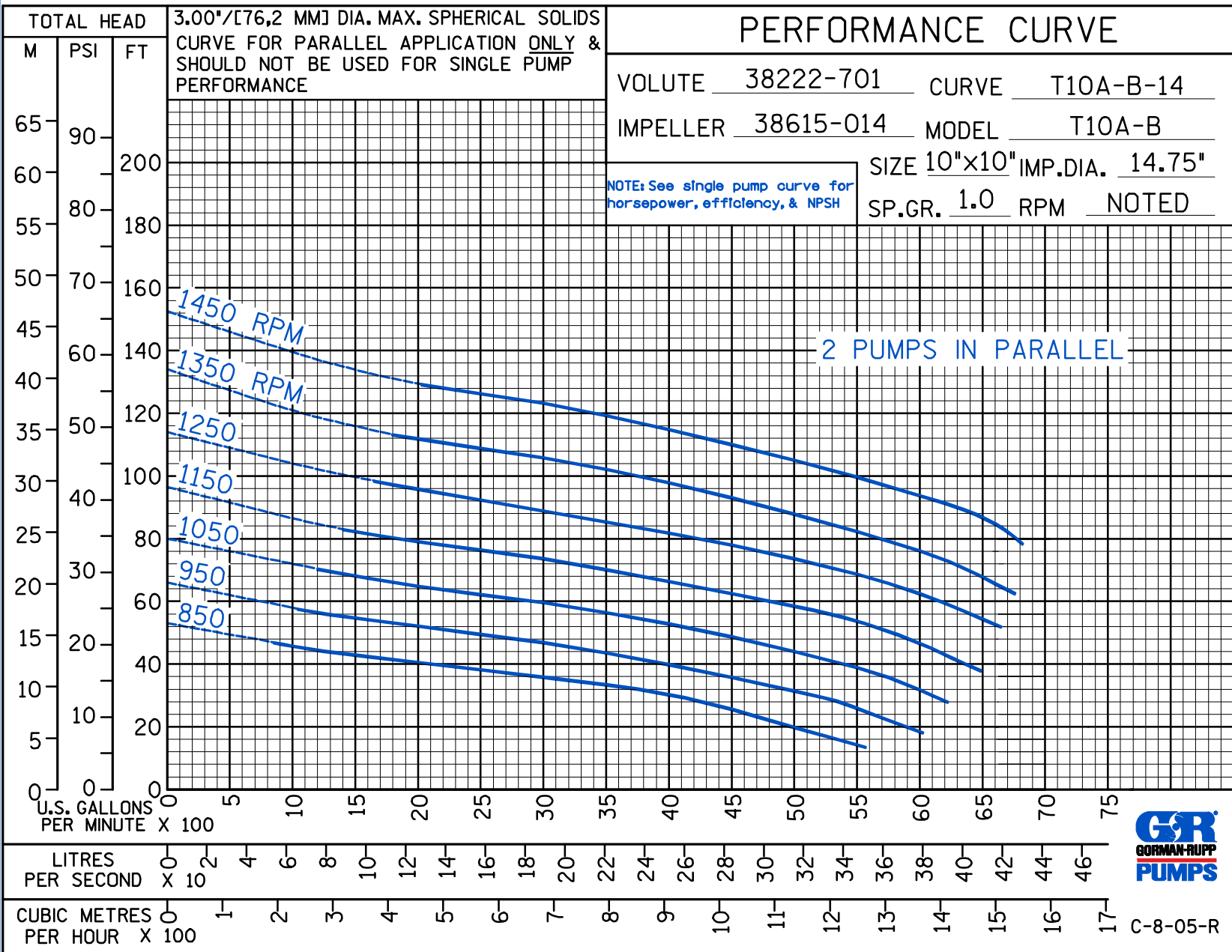

C-8-05-R



**THE GORMAN-RUPP COMPANY • MANSFIELD, OHIO**  
 GORMAN-RUPP OF CANADA LIMITED • ST. THOMAS, ONTARIO, CANADA

www.grpumps.com  
 Specifications Subject to Change Without Notice

Printed in U.S.A.

DS

# PERFORMANCE CURVE

VOLUTE 38222-701 CURVE T10A-B-15  
 IMPELLER 38615-014 MODEL T10A-B  
 SIZE 10"X10" IMP.DIA. 14.75"  
 SP.GR. 1.0 RPM NOTED

NOTE: Series operation is limited by the operating pressure & NPSH requirement of a single pump. See single pump curve for NPSH, EFF., & HP.

Performance shown does not include any interconnecting piping

2 PUMPS IN SERIES

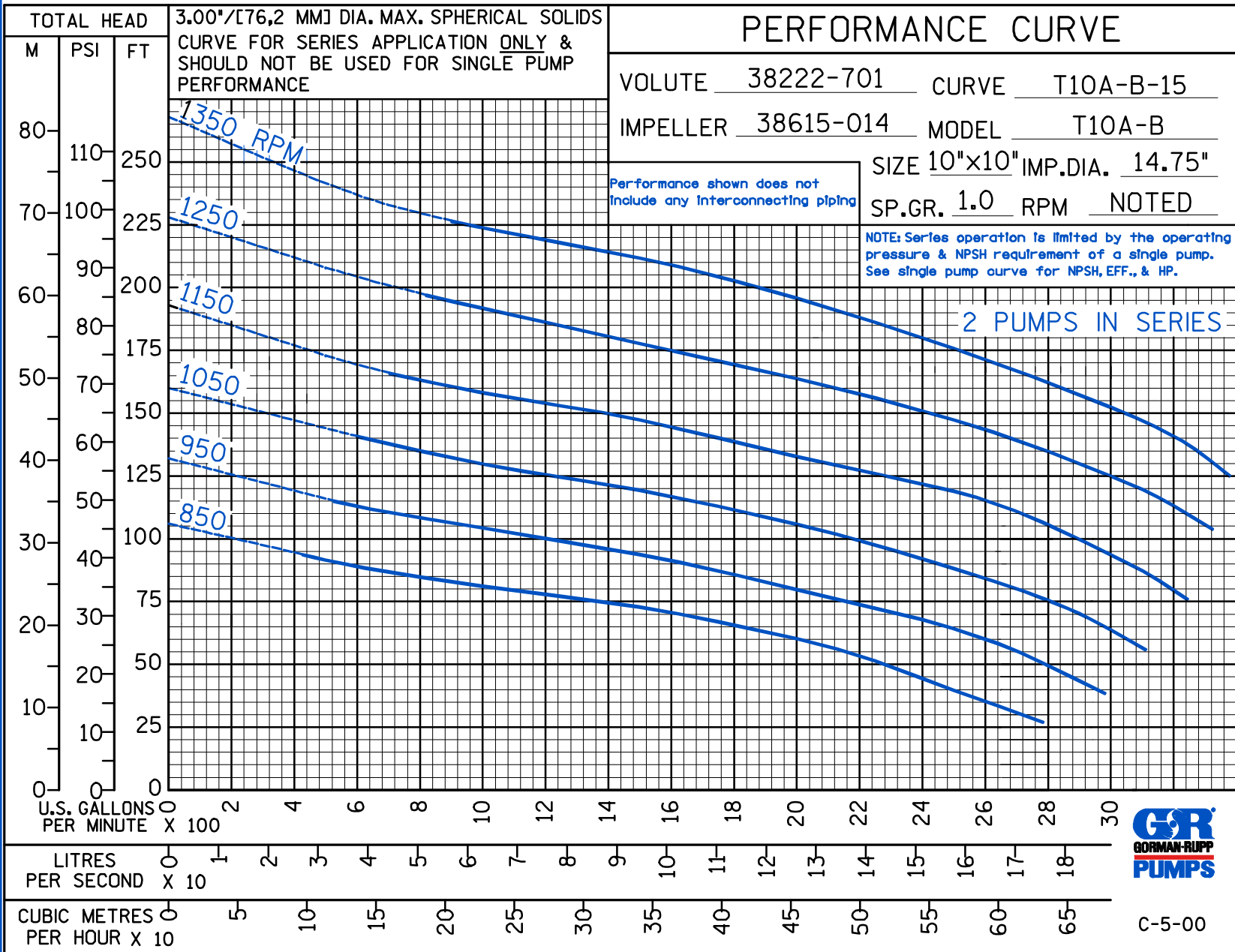

C-5-00



THE GORMAN-RUPP COMPANY • MANSFIELD, OHIO  
 GORMAN-RUPP OF CANADA LIMITED • ST. THOMAS, ONTARIO, CANADA  
 www.grpumps.com

Specifications Subject to Change Without Notice

© Copyright by the Gorman-Rupp Company 2009

Printed in U.S.A.



**THE GORMAN-RUPP COMPANY • MANSFIELD, OHIO**  
 GORMAN-RUPP OF CANADA LIMITED • ST. THOMAS, ONTARIO, CANADA  
 www.grpumps.com

© Copyright by the Gorman-Rupp Company 2009

Specifications Subject to Change Without Notice

Printed in U.S.A.

TOTAL HEAD

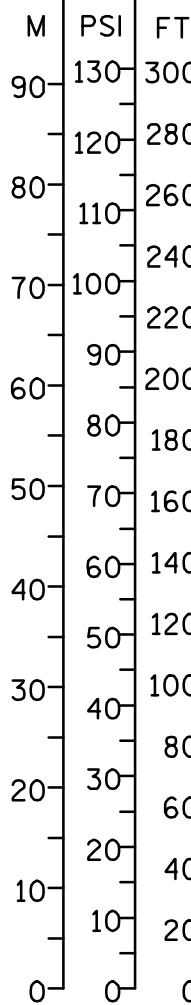

REPRIMING LIFTS									
RPM	650	750	850	950	1050	1150	1250	1350	1450
FEET	6'	11'	14'	15'	16'	18'	20'	21'	22'
METERS	1,8	3,4	4,3	4,6	4,9	5,5	6,1	6,4	6,7

Figure NPSH required prior to using above table. DO NOT use as available Suction Lifts. 3.00"/[76,2 MM] DIA. MAX. SPHERICAL SOLIDS

**PERFORMANCE CURVE**

VOLUTE 38222-701 CURVE T10A-B-16  
 IMPELLER 38611-024 MODEL T10A-B  
 SIZE 10"X10" IMP.DIA. 14.75"  
 SP.GR. 1.0 RPM NOTED

PERFORMANCE BASED ON T10A-B PUMP WITH CONTINUOUS VANE IMPELLER

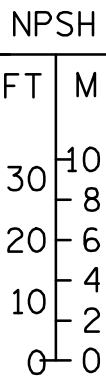
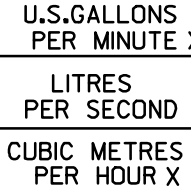
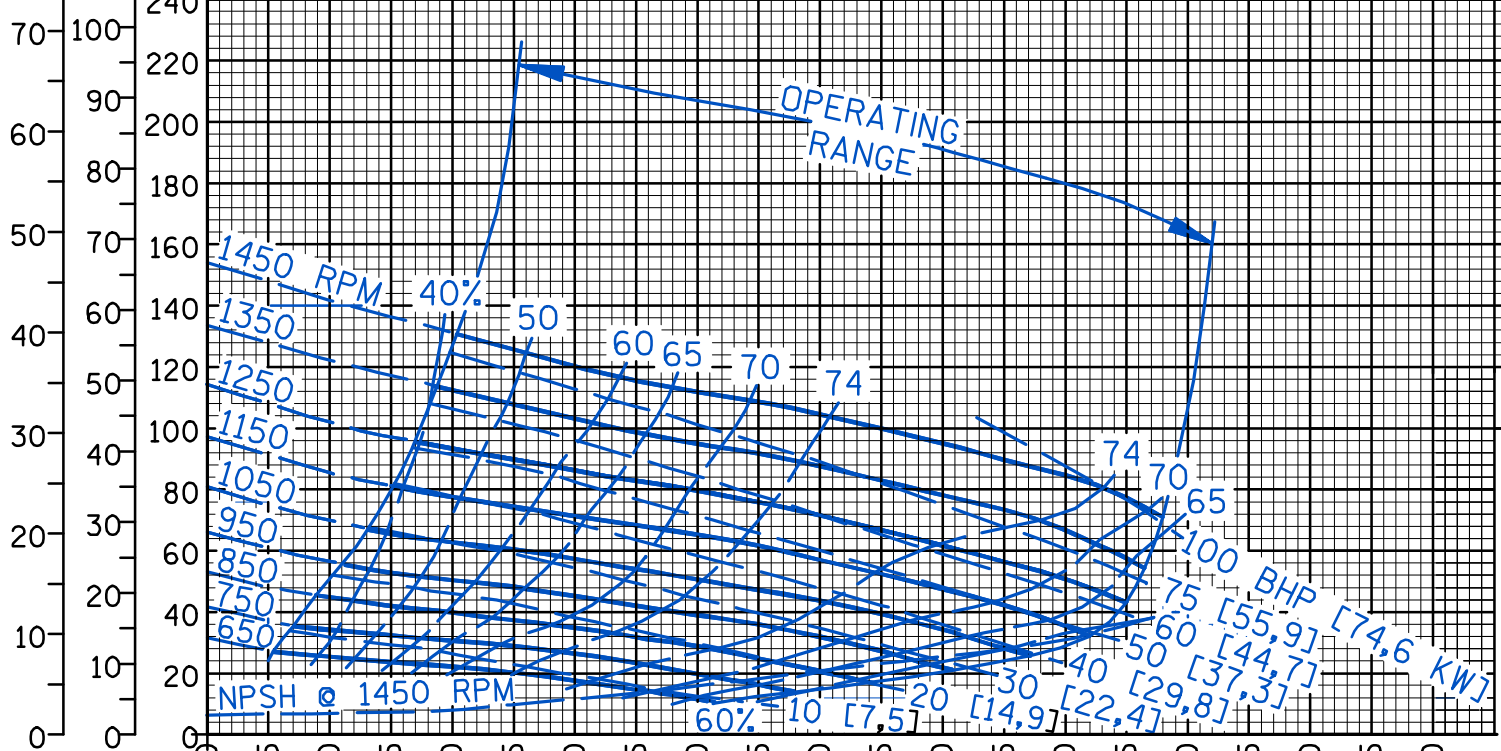

T-6-09

CDS

Curve Data

Sec. 55

PAGE 2451.14  
JUNE 2009