

Priming Assisted Centrifugal Pump



Model PAH8A60C-B

Size 10" x 8"



PUMP SPECIFICATIONS

- Size:** 10" x 8" (254 mm x 203 mm) Flanged.
- Casing:** Ductile Iron 65-45-12.
Maximum Casing Pressure 265 psi (1827 kPa).*
- Maximum Operating Pressure 250 psi (1723 kPa) at Temperatures up to 100° F (37° C) Based on System Component Limitations.*
- Enclosed Type, Two Vane Impeller:** Ductile Iron 65-45-12.
Handles 3" (76,2 mm) Diameter Spherical Solids.
- Suction Head:** Gray Iron 30.
- Suction Spool:** Gray Iron 30.
- Impeller Shaft:** Alloy Steel 4150M.
- Externally Adjustable, Replaceable Wear Ring:** Ductile Iron 65-45-12.
- Pedestal:** Gray Iron 30.
- Seal Plate:** Gray Iron 30.
- Shaft Sleeve:** Stainless Steel 303/304.
- Priming Chamber:** Gray Iron 30 Housing w/Stainless Steel Float and Linkage.
- Discharge Check Valve:** Ductile Iron Housing w/Buna-N Flapper.
- Radial Bearing:** Open Roller.
- Thrust Bearing:** Open Double Ball.
- Bearing Cavity Lubrication:** Lithium EP2 Grease.
- Gaskets:** Red Rubber and Buna-N.
- O-Rings:** Buna-N.
- Hardware:** Standard Plated Steel.
- Seal Cavity Oil Level Sight Gauges.**
- * Consult Factory for Applications Exceeding Maximum Pressure and/or Temperature Indicated.
- Standard Equipment:** Belt Driven Air Compressor. Strainer.
- Optional Equipment:** Base. NPT Threaded Flange Kit. Coupling. TEFC Motor. Suction Vacuum and Discharge Pressure Gauge Kit.



WARNING!

Do not use in explosive atmosphere or for pumping volatile flammable liquids.

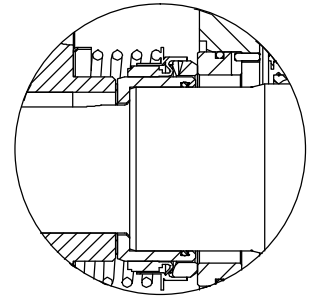
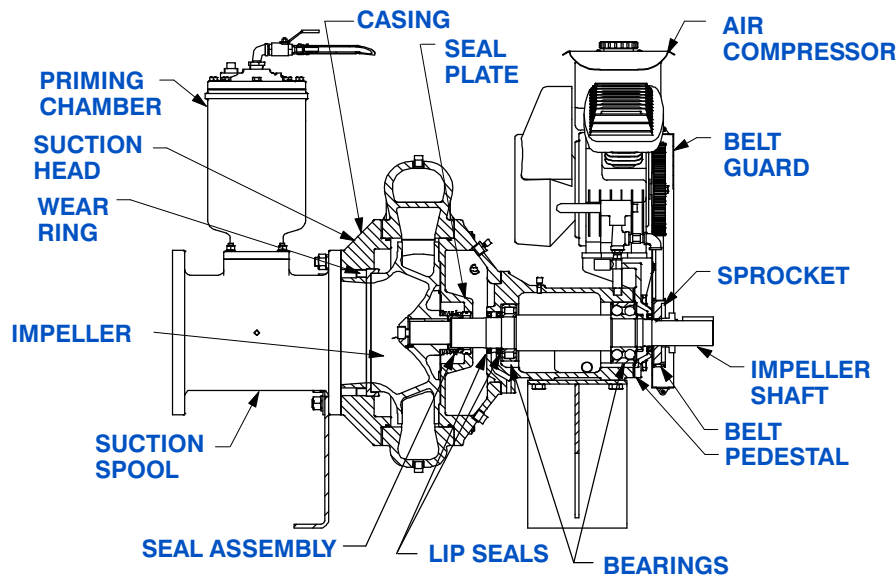

SEAL DETAIL

Mechanical, SAE 30 Non-Detergent Oil-Lubricated. Silicon Carbide Rotating Face and Stationary Seat. Fluorocarbon Elastomers (DuPont Viton® or Equivalent). Stainless Steel 316 Cage and Stainless Steel 18-8 Spring. Maximum Temperature of Liquid Pumped 160°F (71°C).*



GORMAN-RUPP PUMPS

www.grpumps.com

Specifications Subject to Change Without Notice

Printed in U.S.A.

Specification Data

SECTION 43, PAGE 400

APPROXIMATE
DIMENSIONS and WEIGHTS

NET WEIGHT: 1650 LBS. (619 KG.)
SHIPPING WEIGHT: 1850 LBS. (761 KG.)
EXPORT CRATE SIZE: 170 CU. FT. (3,6 CU. M.)

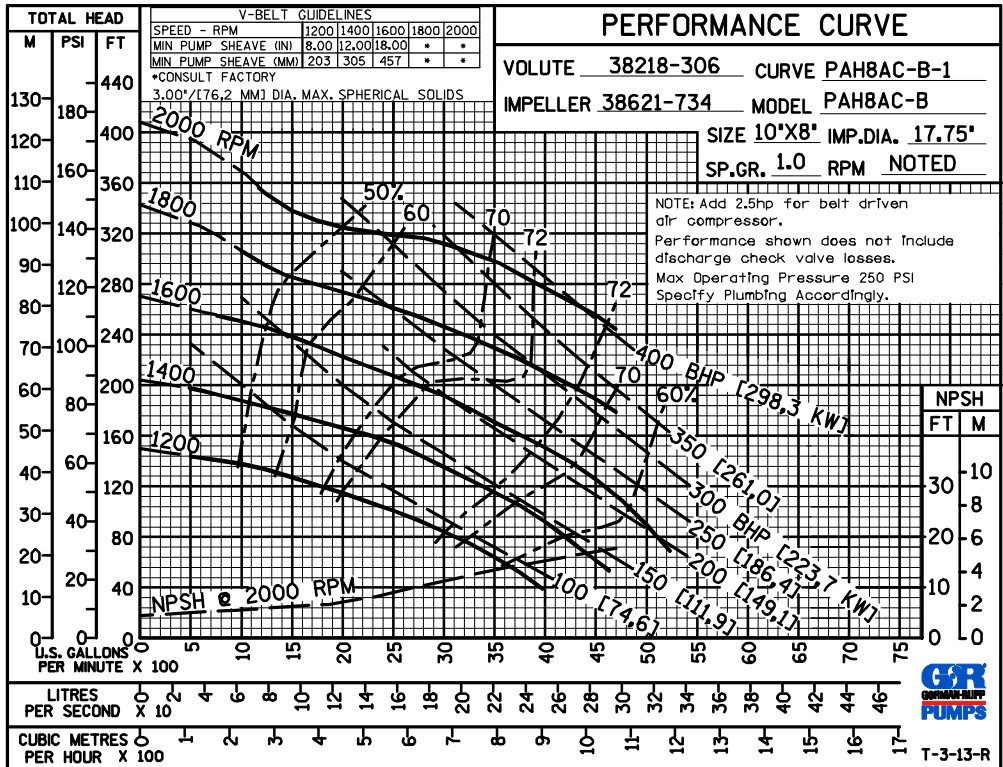
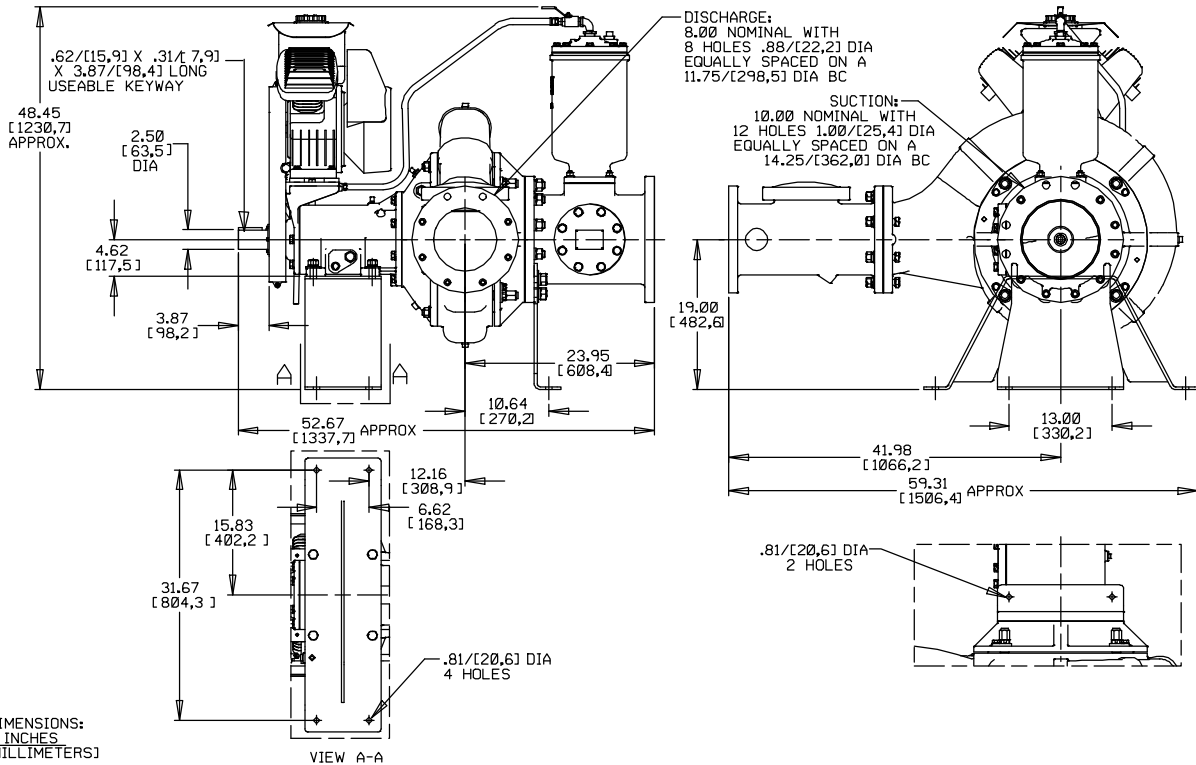

GORMAN-RUPP PUMPS

www.grpumps.com

Specifications Subject to Change Without Notice

Printed in U.S.A.

PERFORMANCE
BASED ON
WATER

TRIMMED
IMPELLER

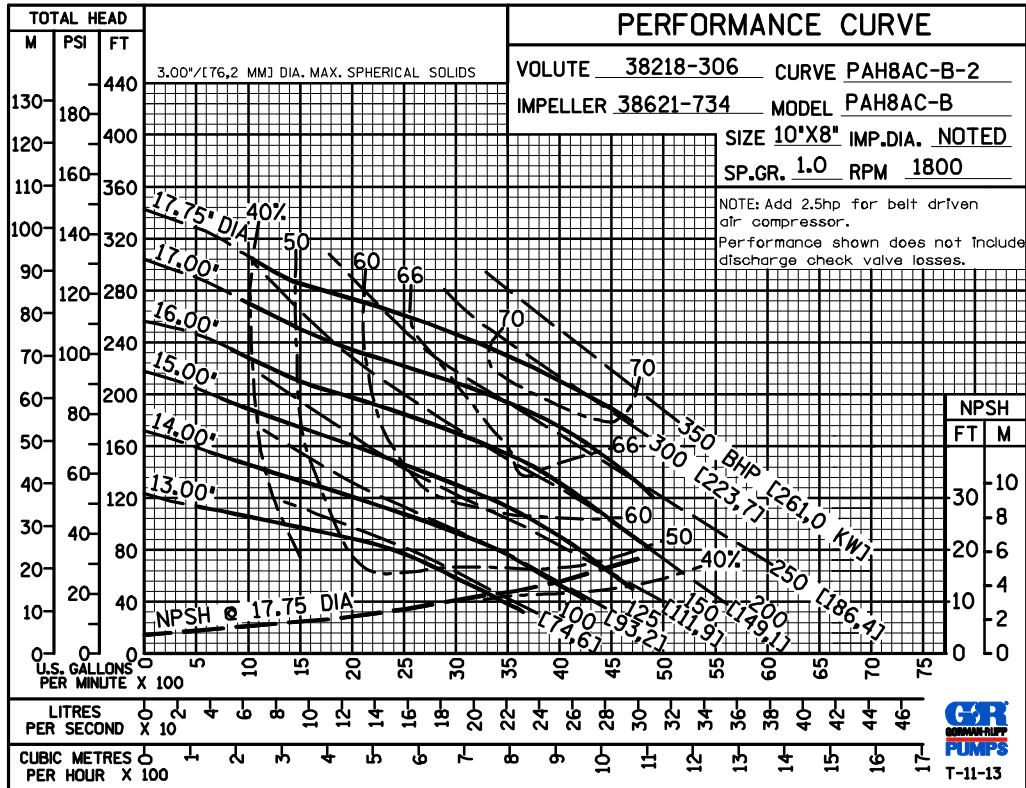

GORMAN-RUPP PUMPS

www.grpumps.com

Specifications Subject to Change Without Notice

Printed in U.S.A.