



Priming Assisted Centrifugal Pump

Model PAH4E60C-B

Size 6" x 4"



PUMP SPECIFICATIONS

Size: 6" x 4" (152 mm x 102 mm) Flanged.

Casing: Ductile Iron 65-45-12.

Maximum Casing Pressure 285 psi (1965 kPa).*

Maximum Operating Pressure 250 psi (1723 kPa) at Temperatures up to 100° F (37° C) Based on System Component Limitations.*

Enclosed Type, Two Vane Impeller: Ductile Iron 65-45-12.

Handles 3" (76.2 mm) Diameter Spherical Solids.

Suction Head: Gray Iron 30.

Suction Spool: Gray Iron 30.

Impeller Shaft: Alloy Steel 4150M.

Replaceable Wear Ring: Ductile Iron 65-45-12.

Bearing Pedestal: Gray Iron 30.

Seal Plate: Gray Iron 30.

Shaft Sleeve: Stainless Steel 303/304.

Priming Chamber: Gray Iron 30 Housing w/Stainless Steel Float and Linkage.

Discharge Check Valve: Ductile Iron Housing w/Buna-N Flapper.

Radial Bearing: Open Roller.

Thrust Bearing: Open Double Ball.

Bearing Cavity Lubrication: Lithium EP2 Grease.

Gaskets: Vegetable Fiber, Buna-N and Red Rubber.

O-Rings: Buna-N.

Hardware: Standard Plated Steel.

Seal Cavity Oil Level Sight Gauges.

* Consult Factory for Applications Exceeding Maximum Pressure and/or Temperature Indicated.

Standard Equipment: Belt Driven Air Compressor. Strainer.

Optional Equipment: Base. NPT Threaded Flange Kit. Coupling. TEFC Motor. Suction Vacuum and Discharge Pressure Gauge Kit.

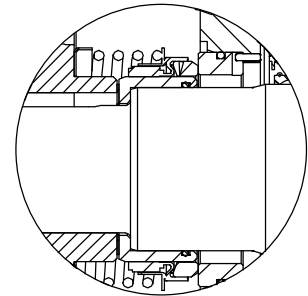
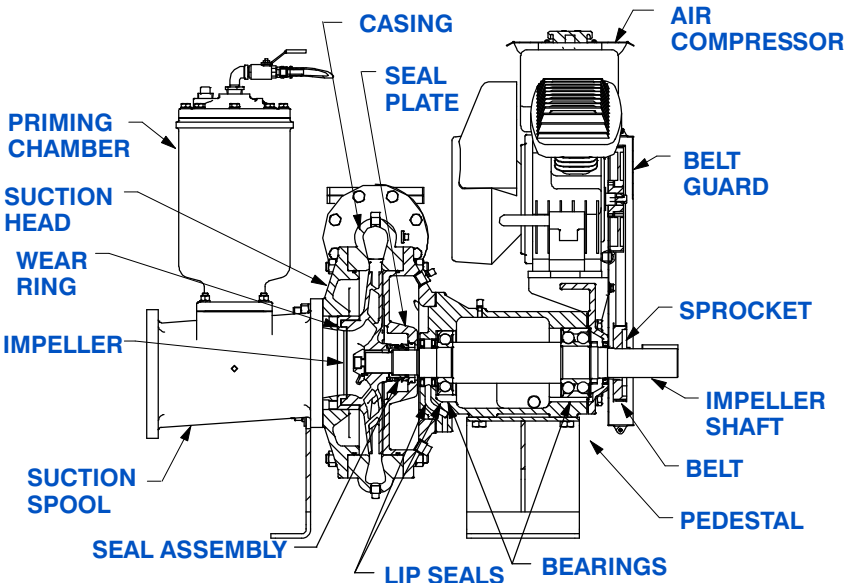

SEAL DETAIL

Mechanical, SAE 30 Non-Detergent Oil-Lubricated. Silicon Carbide Rotating Face and Stationary Seat. Fluorocarbon Elastomers (DuPont Viton® or Equivalent). Stainless Steel 18-8 Cage and Spring. Maximum Temperature of Liquid Pumped 160°F (71°C).*



GORMAN-RUPP PUMPS

www.grpumps.com

Specifications Subject to Change Without Notice

Printed in U.S.A.

Specification Data

SECTION 43, PAGE 238

APPROXIMATE
DIMENSIONS and WEIGHTS

NET WEIGHT: 1010 LBS. (458,1 KG.)
SHIPPING WEIGHT: 1125 LBS. (510,3 KG.)
EXPORT CRATE SIZE: 59 CU. FT. (1,7 CU. M.)

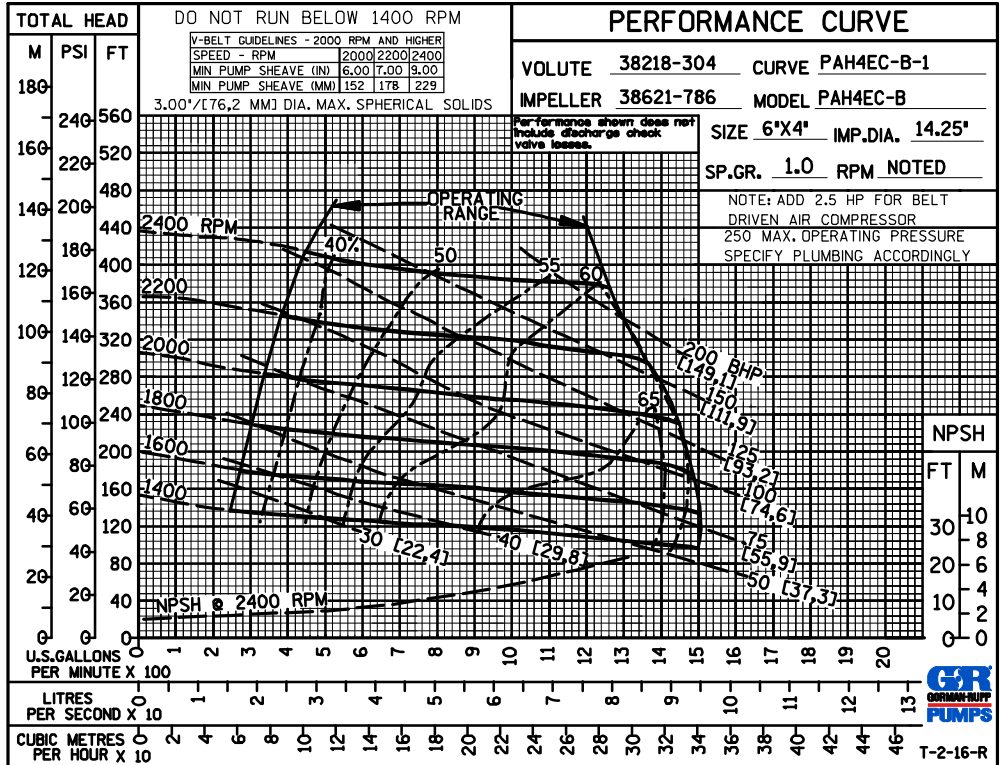
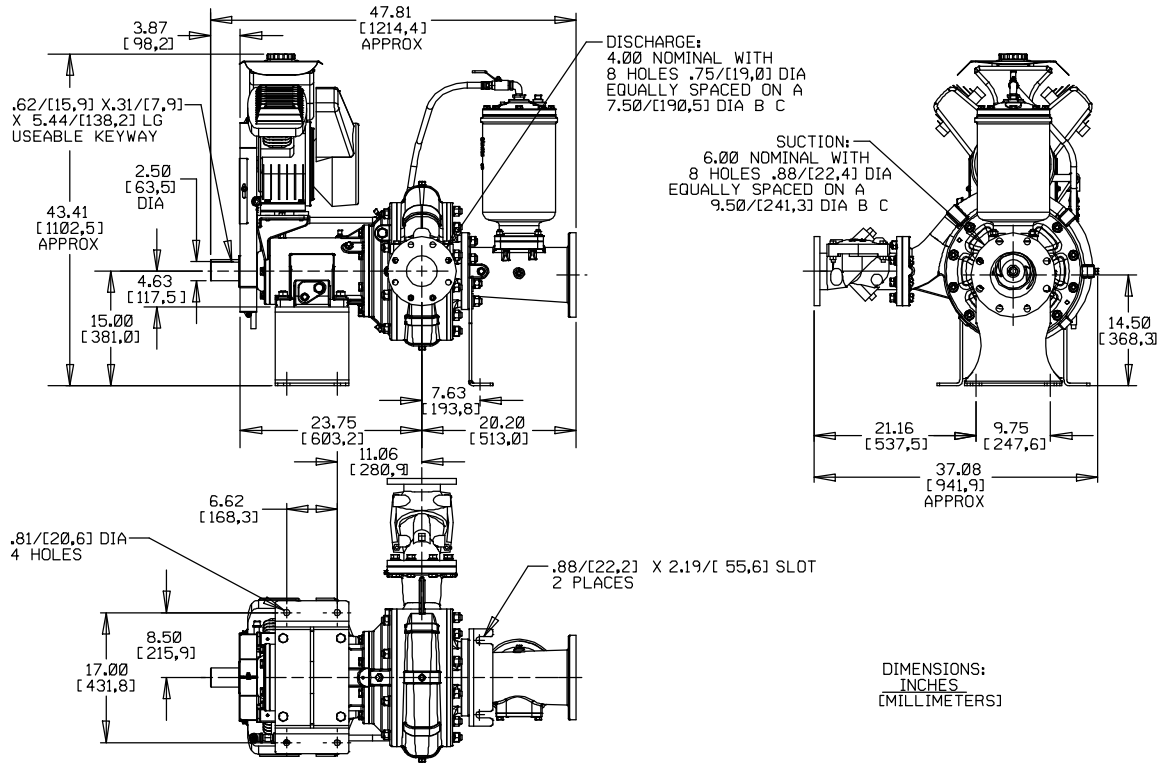

GORMAN-RUPP PUMPS

www.grpumps.com

Specifications Subject to Change Without Notice

Printed in U.S.A.