



Priming Assisted Centrifugal Pump Model PAH8C60C-B

Size 10" x 8"



PUMP SPECIFICATIONS

- Size:** 10" x 8" (254 mm x 203,2 mm) Flanged.
- Casing:** Ductile Iron 65-45-12.
Maximum Casing Pressure 291 psi (2006 kPa).*
- Maximum Operating Pressure 250 psi (1723 kPa) at Temperatures up to 100° F (37° C) Based on System Component Limitations.*
- Enclosed Type, Five Vane Impeller:** Ductile Iron 65-45-12.
Handles 3" (76,2 mm) Diameter Spherical Solids.
- Suction Head:** Ductile Iron 65-45-12
- Suction Spool:** Gray Iron 30.
- Impeller Shaft:** Alloy Steel 4150M.
- Replaceable Wear Ring:** Ductile Iron 65-45-12.
- Bearing Pedestal:** Gray Iron 30.
- Seal Plate:** Gray Iron 30.
- Shaft Sleeve:** Stainless Steel 303/304.
- Priming Chamber:** Gray Iron 30 Housing w/Stainless Steel Float and Linkage.
- Discharge Check Valve:** Ductile Iron Housing w/Buna-N Flapper.
- Radial Bearing:** Open Single Ball.
- Thrust Bearing:** Open Double Ball.
- Bearing Cavity Lubrication:** Lithium EP2 Grease.
- Gaskets:** Buna-N and Red Rubber.
- O-Rings:** Buna-N.
- Hardware:** Standard Plated Steel.
- Seal Cavity Oil Level Sight Gauges.**

** Consult Factory for Applications Exceeding Maximum Pressure and/or Temperature Indicated.*

Standard Equipment: Belt Driven Air Compressor. Strainer.

Optional Equipment: Base. NPT Threaded Flange Kit. Coupling. TEFC Motor. Heated Priming Chamber Kit. Suction Vacuum and Discharge Pressure Gauge Kit.

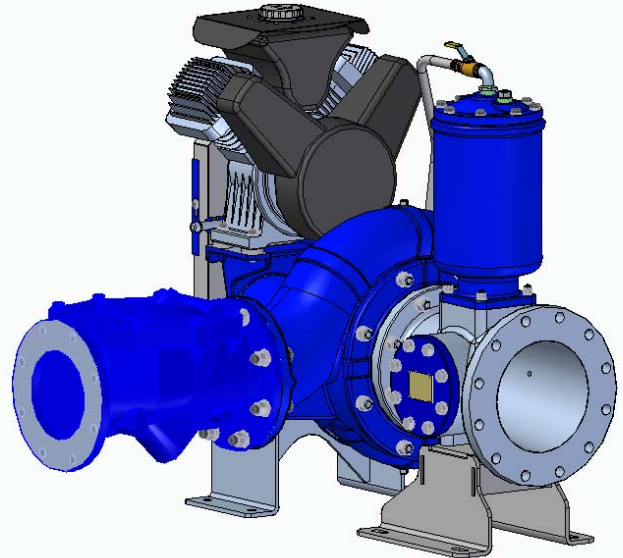

WARNING!

Do not use in explosive atmosphere or for pumping volatile flammable liquids.

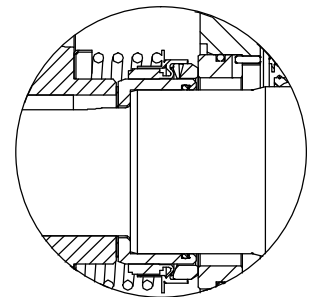
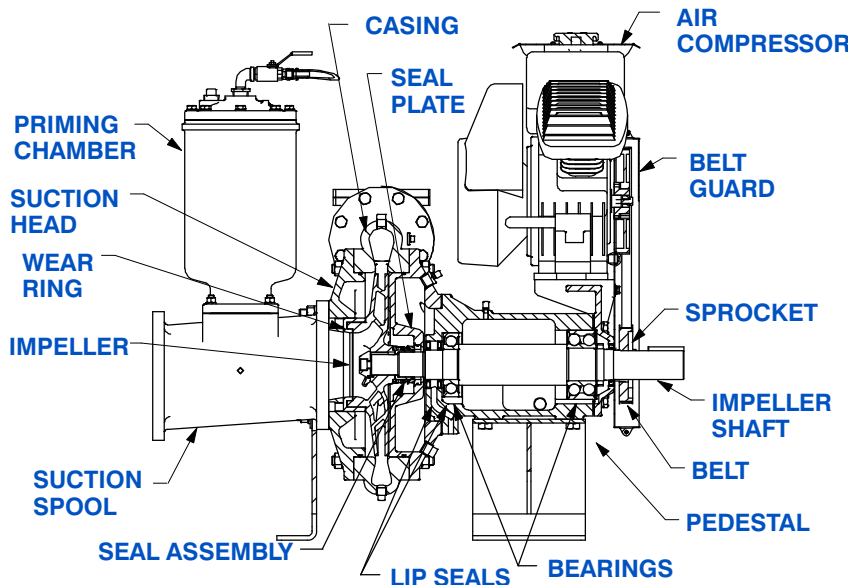

SEAL DETAIL

Mechanical, SAE 30 Non-Detergent Oil-Lubricated. Silicon Carbide Rotating Face and Stationary Seat. Fluorocarbon Elastomers (DuPont Viton® or Equivalent). Stainless Steel 316 Cage and Spring. Maximum Temperature of Liquid Pumped 160°F (71° C).*



GORMAN-RUPP PUMPS

www.grpumps.com

Specifications Subject to Change Without Notice

Printed in U.S.A.

Specification Data

SECTION 43, PAGE 425

APPROXIMATE DIMENSIONS and WEIGHTS

NET WEIGHT:
SHIPPING WEIGHT:
EXPORT CRATE SIZE:

1550 LBS. (703,1 KG.)
1650 LBS. (748,4 KG.)
95 CU. FT. (2,7 CU. M.)

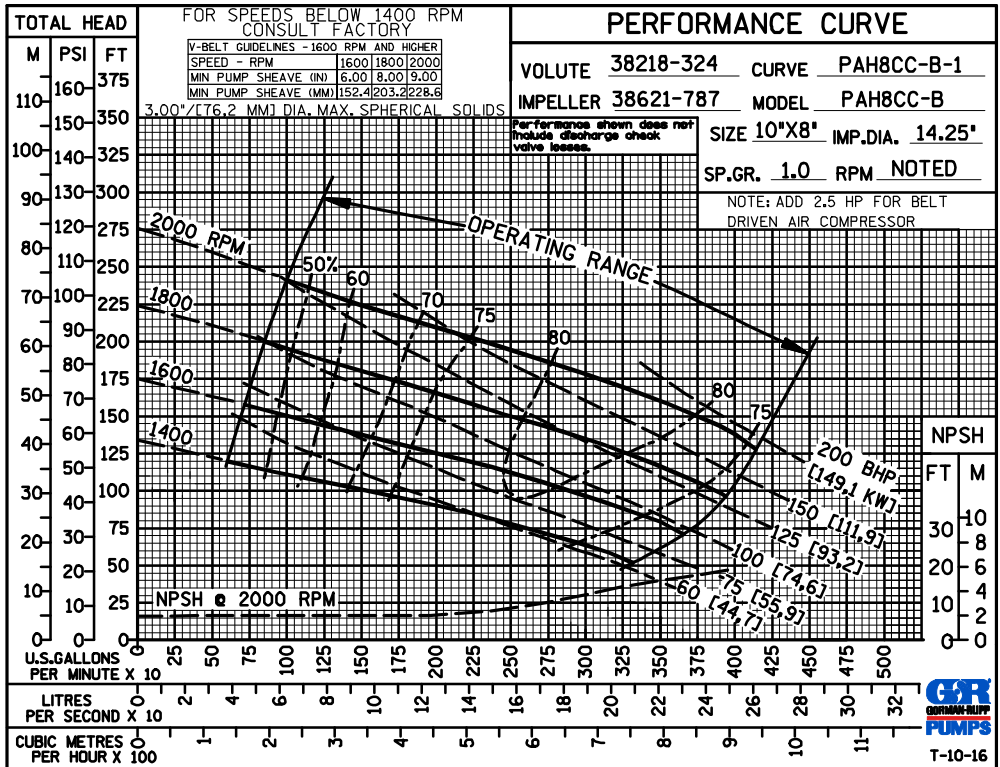
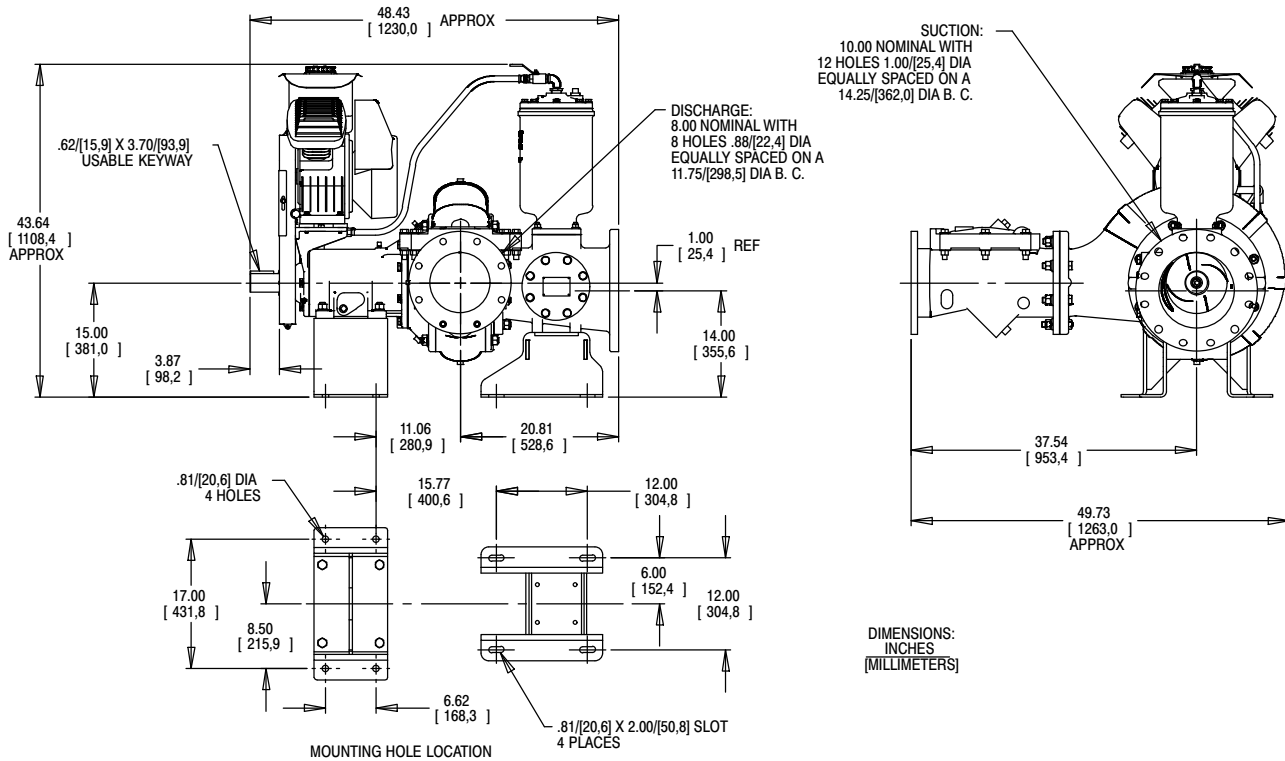

GORMAN-RUPP PUMPS

www.grpumps.com

Specifications Subject to Change Without Notice

Printed in U.S.A.

PERFORMANCE
BASED ON
WATER
TRIMMED
IMPELLER

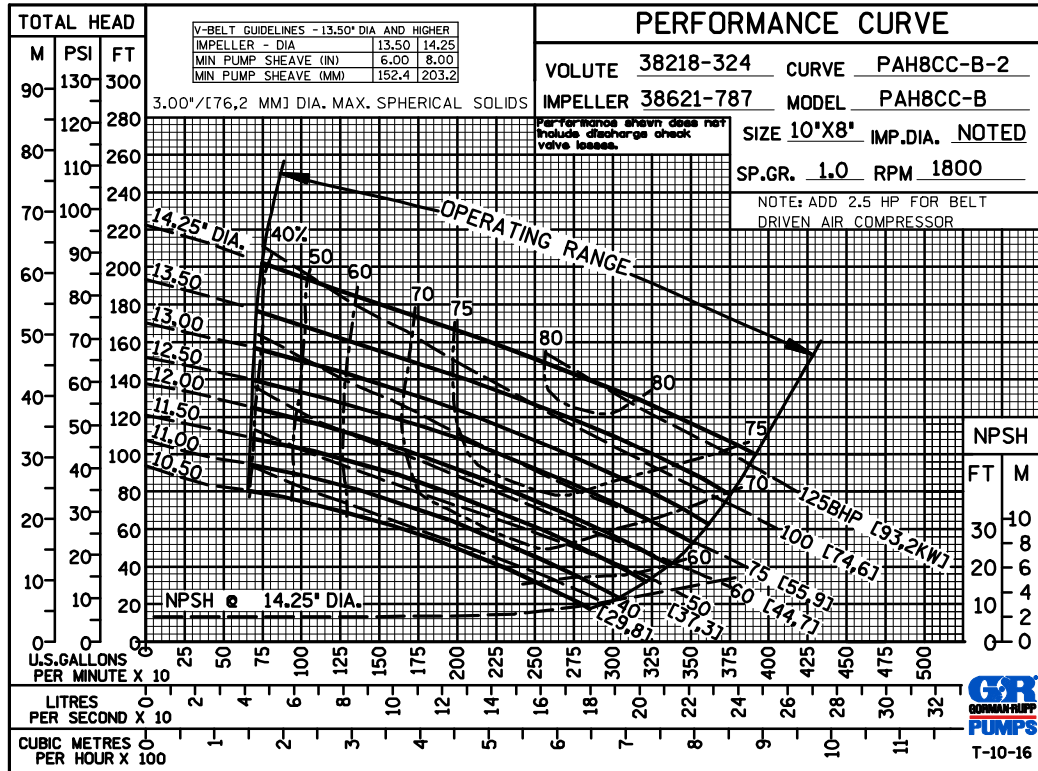

GORMAN-RUPP PUMPS

www.grpumps.com

Specifications Subject to Change Without Notice

Printed in U.S.A.