



Priming Assisted Centrifugal Pump

Model PAH16A60C-B

Size 18" x 16"



PUMP SPECIFICATIONS

Size: 18" x 16" (457 mm x 406 mm) Flanged.

Casing: Ductile Iron 65-45-12.

Maximum Operating Pressure 133 psi (917 kPa).*

Enclosed Type, Four Vane Impeller: Ductile Iron 80-55-06.

Handles 4" (101,6 mm) Diameter Spherical Solids.

Suction Head: Gray Iron 30.

Suction Spool: Gray Iron 30.

Impeller Shaft: Alloy Steel 4150M.

Replaceable Wear Ring: Ductile Iron 65-45-12.

Bearing Pedestal: Gray Iron 30.

Seal Plate: Ductile Iron 65-45-12.

Shaft Sleeve: Stainless Steel 303/304.

Priming Chamber: Gray Iron 30 Housing ^{w/}Stainless Steel Float and Linkage.

Discharge Check Valve: Ductile Iron Housing ^{w/}Buna-N Flapper.

Radial Bearing: Open Single Row Straight Roller.

Radial/Thrust Bearing: Open Double Row Tapered Roller.

Bearing Cavity Lubrication: Lithium EP2 Grease.

Gaskets: Resistant Synthetic Rubber, Vegetable Fiber ^{w/}Compressed Synthetic Fibers.

O-Rings: Buna-N.

Hardware: Standard Plated Steel.

Seal Cavity Oil Level Sight Gauges.

**Consult Factory for Applications Exceeding Maximum Pressure and/or Temperature Indicated.*

Standard Equipment: Belt Driven Air Compressor With Electric Motor Driven Cooling Fan (12 Volt Power Supply Required to be Supplied by End User). Strainer.

Optional Equipment: Base. NPT Threaded Flange Kit. Coupling. TEFC Motor. Suction Vacuum and Discharge Pressure Gauge Kit.

Photo Unavailable at Publishing

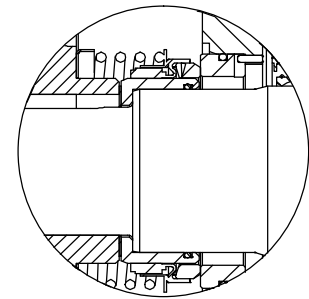
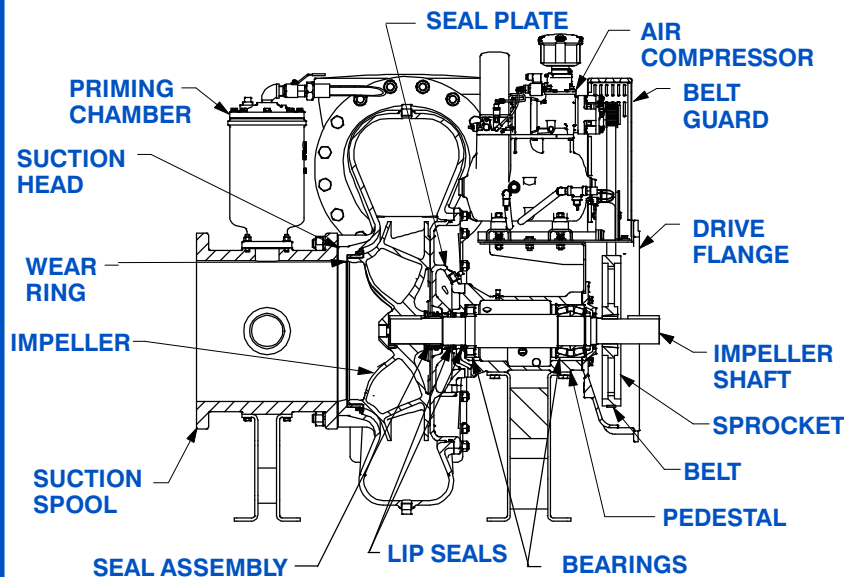

SEAL DETAIL

Mechanical, SAE 30 Non-Detergent Oil-Lubricated. Silicon Carbide Rotating Face and Stationary Seat. Fluorocarbon Elastomers (DuPont Viton® or Equivalent). Stainless Steel 316 Cage and Stainless Steel 18-8 Spring. Maximum Temperature of Liquid Pumped 160°F (71°C).*



GORMAN-RUPP PUMPS

www.grpumps.com

Specifications Subject to Change Without Notice

Printed in U.S.A.

Specification Data

SECTION 43, PAGE 810

**APPROXIMATE
DIMENSIONS and WEIGHTS**

NET WEIGHT: 4150 LBS. (1882 KG.)
SHIPPING WEIGHT: 4350 LBS. (1973 KG.)
EXPORT CRATE SIZE: 215 CU. FT. (6 CU. M.)

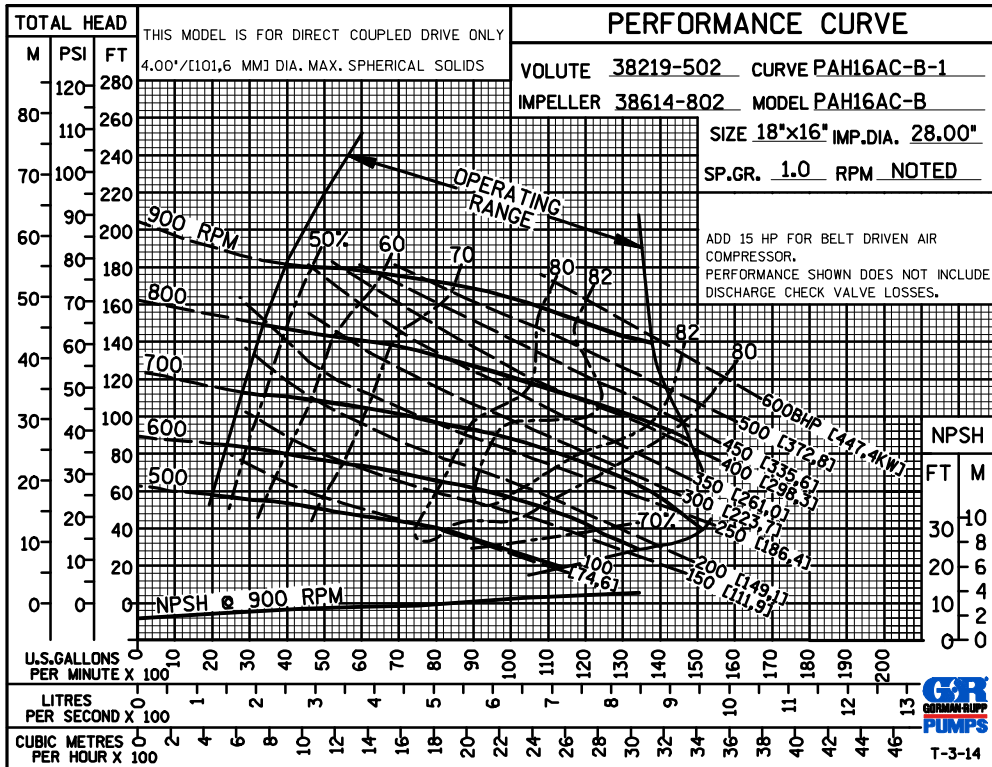
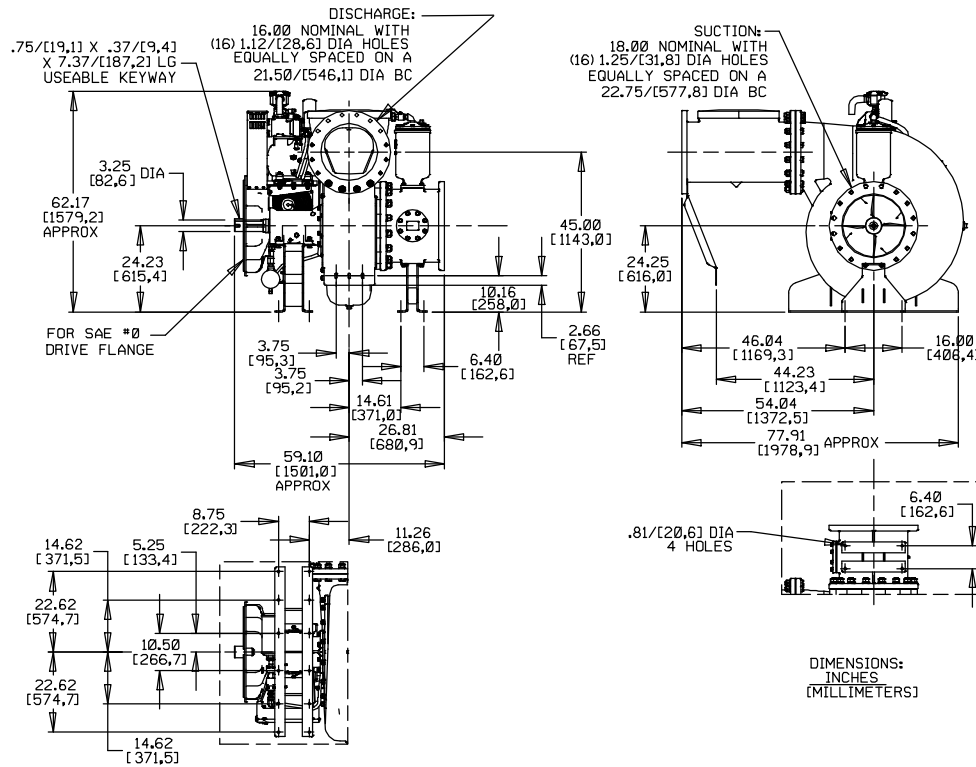

GORMAN-RUPP PUMPS

www.grpumps.com

Specifications Subject to Change Without Notice

Printed in U.S.A.