

Basic Pump



Self Priming Centrifugal Pump

Models RD3A31-B and RD3A32-B

Size 4" x 3"

PUMP SPECIFICATIONS

Size: 4" x 3" (102 mm x 76 mm) Flanged.

Casing: (RD3A31-B) Ductile Iron 65-45-12.
(RD3A32-B) Cast Steel 70-36.

Maximum Operating Pressure 127 psi (876 kPa).*

Enclosed Type, Five Vane Impeller: Aluminum 356-T6.

Handles 3/8" (9,5 mm) Diameter Spherical Solids.

Impeller Shaft: Steel 1045.

Rotor: Copper Alloy C93400.

Bearing Housing: Ductile Iron 65-45-12.

Bearing Housing Lubrication: Grease.

Body Cover: (RD3A31-B) Ductile Iron 65-45-12.
(RD3A32-B) Cast Steel 70-36.

Center/Spacer Plate: (RD3A31-B) Ductile Iron 65-45-12.
(RD3A32-B) Cast Steel 70-36.

Radial Bearing: Permanently Sealed Single Row Ball Type.

Thrust Bearing: Permanently Sealed Single Row Ball Type.

Gaskets: Vegetable Fiber, PTFE and Cork.

Priming: Rotary Vane Type with Built-in Spring-Loaded Priming Assist Valve.

Optional Equipment: Cast Steel 70-36 Threaded Suction and Discharge Companion Flange Kit, Copper Alloy C93400 Impeller, Group Grind with Cast Iron Rotor (RD3A31-B Only); Stainless Steel 416 Impeller Shaft, Buna-N Seal, PTFE Seal with Fluorocarbon O-Ring, PTFE Seal with Buna-N O-Ring, Oil Filled Bearing Housing Assembly.

*Consult Factory for Applications Exceeding Maximum Pressure and/or Temperature Indicated.

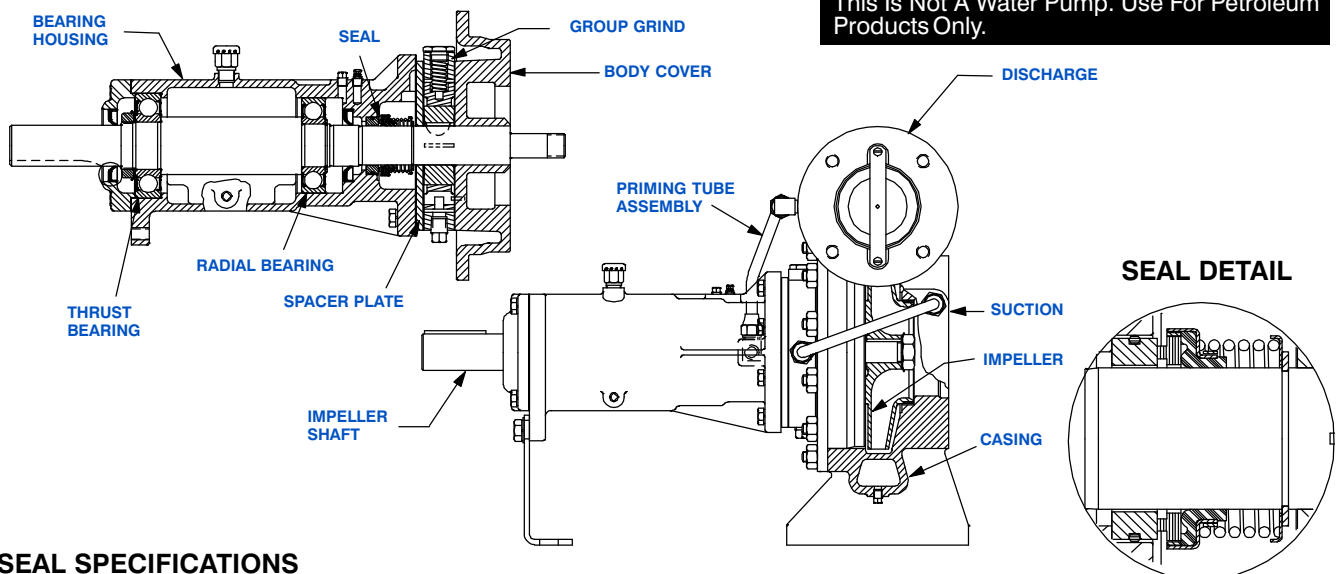

SEAL SPECIFICATIONS

Seal: Mechanical; Self-Lubricated. Fluorocarbon Elastomers (DuPont Viton® or Equivalent). Carbon Rotating Face; Ni-Resist Stationary Face; Maximum Temperature of Liquid Pumped is 160°F (71°C).*



GORMAN-RUPP PUMPS

www.grpumps.com

Specifications Subject to Change Without Notice

Printed in U.S.A.

Specification Data

OVERALL DIMENSIONS
and
APPROXIMATE WEIGHTS

RD3A31-B

RD3A32-B

SECTION 35, PAGE 400

PUMP NET WEIGHT: 238 LBS. (108 KG.) 243 LBS. (110,2 KG.)
SHIPPING NET WEIGHT: 253 LBS. (114,8 KG.) 258 LBS. (117 KG.)
EXPORT CRATE SIZE: 12.8 CU. FT. (0,36 CU. M.)

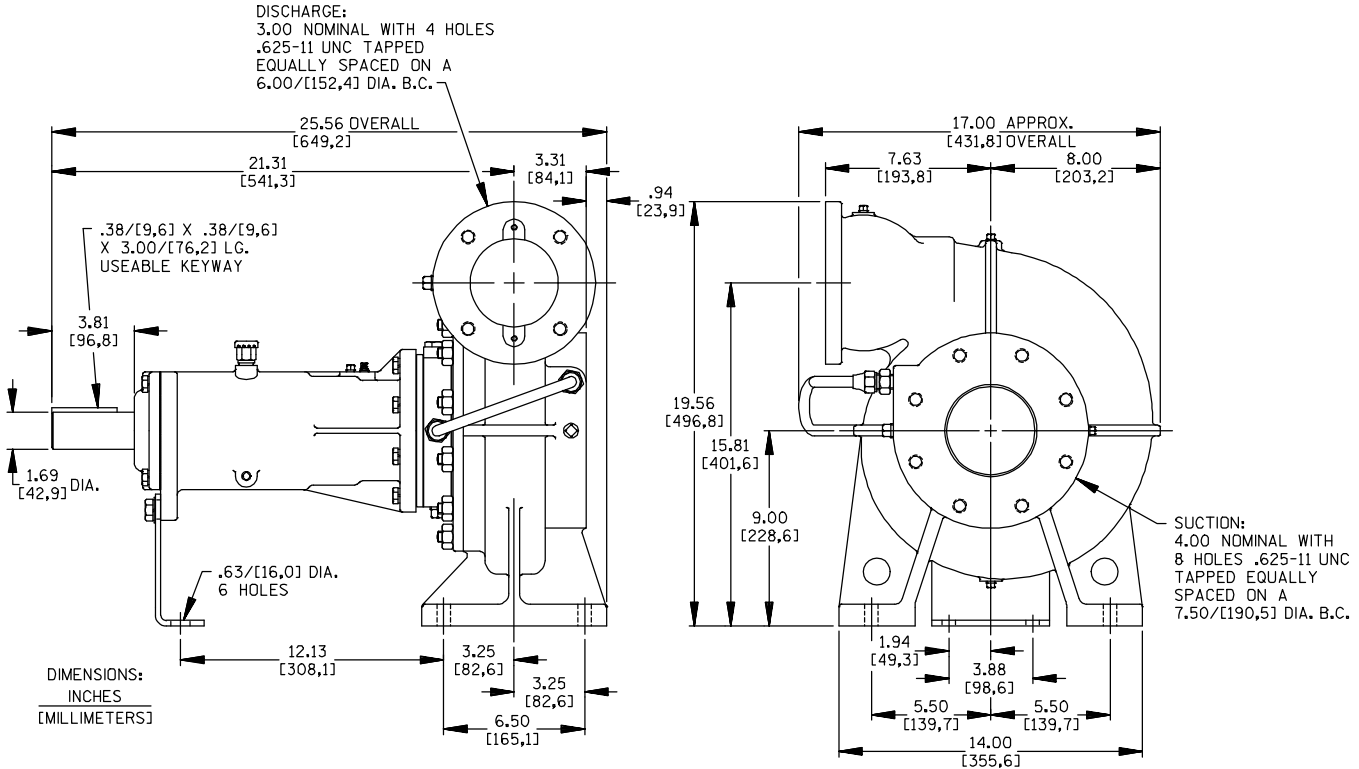

Air Release Valve Required When Static Discharge Pressure Exceeds 8 psi (55 kPa).

**PERFORMANCE
BASED ON
PETROLEUM
TRIMMED
IMPELLER**

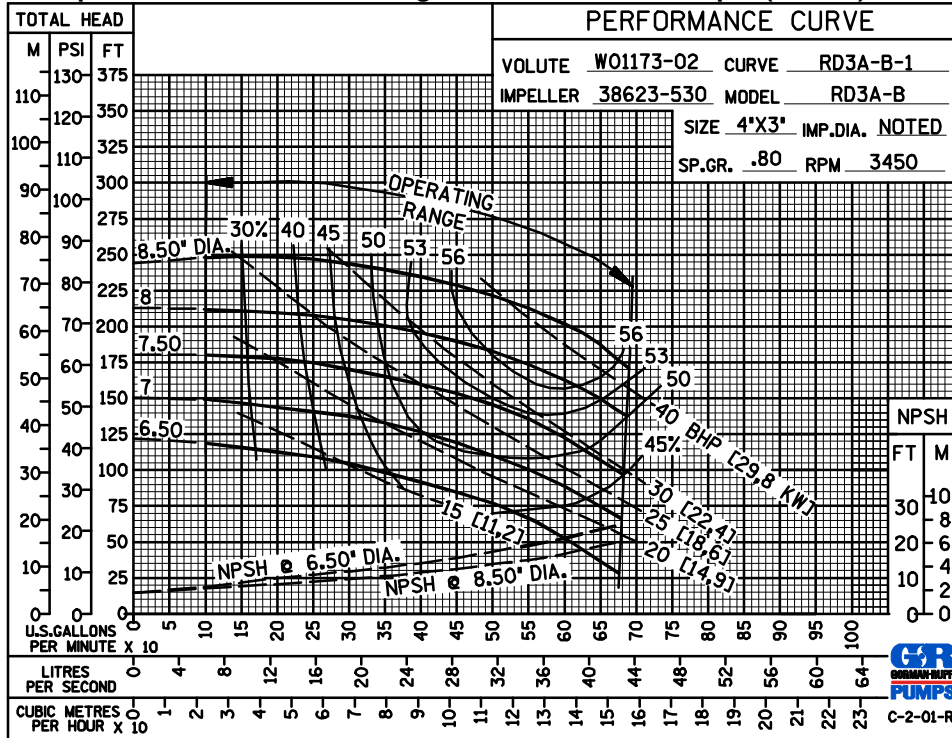

GORMAN-RUPP PUMPS

www.grpumps.com

Specifications Subject to Change Without Notice

Printed in U.S.A.

**50 HERTZ
PERFORMANCE
BASED ON
PETROLEUM
TRIMMED
IMPELLER**

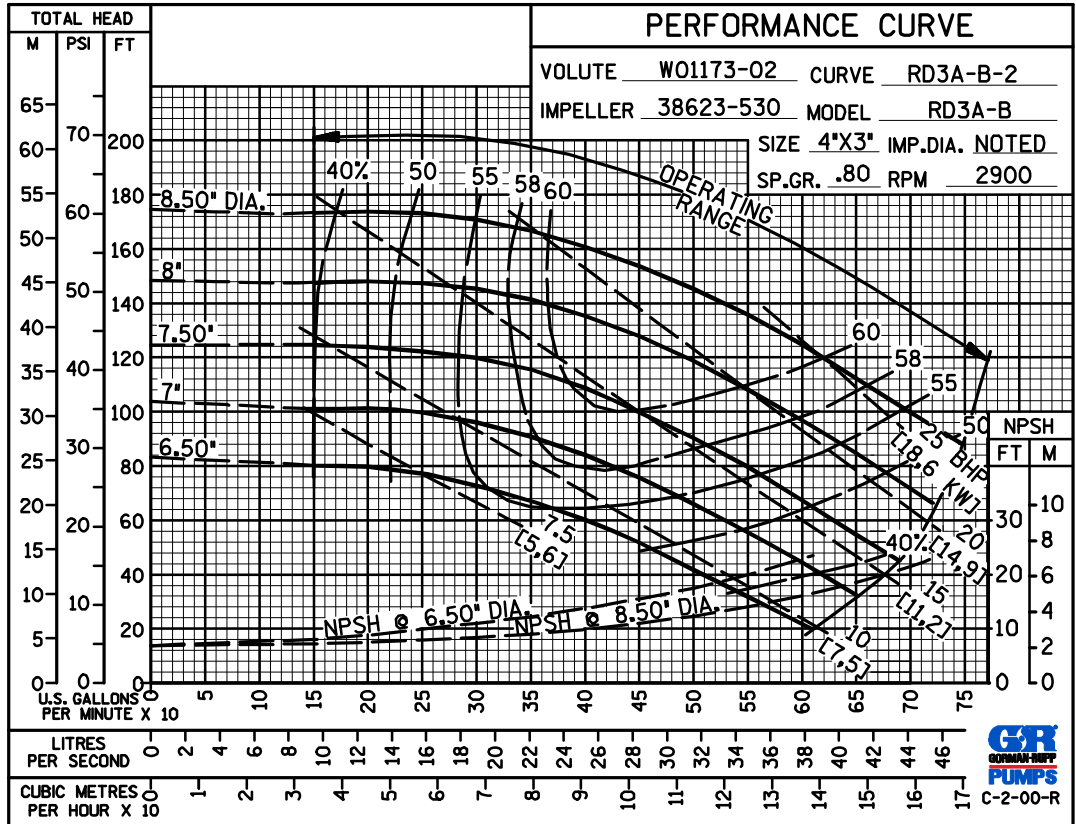

GORMAN-RUPP PUMPS

www.grpumps.com

Specifications Subject to Change Without Notice

Printed in U.S.A.