

CM Booster

Horizontal, multistage centrifugal boosters
50/60 Hz



be
think
innovate

GRUNDFOS 

1. Product introduction	4
Product range	4
Applications	4
Pumped liquids	4
Identification	5
Installation	6
Selection guide for residential applications	8
Selection guide for commercial applications	9
2. CMBE TWIN	10
Applications	10
Product Description	10
Motor	10
Features	10
Operating conditions	11
Electrical data	11
Approvals	11
Wetted parts	11
Dimensional drawings	11
Control panel	11
Performance curves	12
3. CMBE	13
Applications	13
Product Description	13
Motor	13
Operating conditions	13
Electrical data	14
Approvals	14
Wetted parts	14
Dimensional drawings	14
Materials	14
Control panel	14
Performance curves	15
4. CMB-SP PM 2	16
Applications	16
Motor	16
Features	16
Versions	16
Operating conditions	16
Electrical data	16
Approvals	16
Wetted parts	17
Dimensional drawings	17
Performance curves	17
5. CMB PM 2	18
Applications	18
Motor	18
Features	18
Operating conditions	18
Electrical data	18
Approvals	18
Wetted parts	18
Dimensional drawings	19
Performance curves	19
6. CMB-SP PM 1	20
Applications	20
Motor	20
Features	20
Versions	20
Operating conditions	20
Electrical data	20

Approvals	20
Wetted parts	21
Dimensional drawings	21
Performance curves	21
7. CMB PM 1	22
Applications	22
Motor	22
Features	22
Operating conditions	22
Electrical data, 50 Hz	22
Approvals	22
Wetted parts	22
Dimensional drawings	23
Performance curves	23
8. CMB PT	24
Applications	24
Motor	24
Features	24
Operating conditions	24
Electrical data	25
Approvals	25
Wetted parts	25
Dimensional drawings	25
Performance curves	26
9. CMB PS	27
Applications	27
Motor	27
Features	27
Operating conditions	27
Electrical data	28
Approvals	28
Wetted parts	28
Dimensional drawings	28
Performance range	29
10. Product numbers	30
Accessories	37
11. Grundfos Product Center	39

1. Product introduction

The compact Grundfos CM Booster ensures optimal water pressure for domestic and commercial applications, such as clean water and raw-water supply, pressure boosting, irrigation and dewatering. The booster consists of a Grundfos CME or CM pump and a pressure control unit. The pressure control unit allows the pump to start and stop automatically according to demand.

- CMBE Booster offers constant pressure and high comfort thanks to the variable-speed motor, noiseless operation and built-in protection against dry running, overload, overtemperature and more.
- CMBE TWIN Booster has two pumps. Both pumps run, when there is need for a higher flow to maintain a constant pressure.
- CM Booster with a pressure manager protects the pump against dry-running and cycling, and reduces the number of starts and stops. Self-priming variants for a suction lift of 0-4 metres or 0-8 metres are also available.
- CM Booster with a diaphragm tank reduces the number of starts in case of low water consumption or leakage.
- CM Booster with pressure switch provides on/off operation.

Product range

Grundfos offers these CM Booster variants:

- CMBE TWIN, two-pump pressure boosting for constant pressure, including cascade control and pump alternation
- CMBE, a variable-speed pump for constant pressure
- CMB-SP PM 2, a self-priming pump with a pressure control unit, type Pressure Manager 2
- CMB PM 2, pump with a pressure control unit, type Pressure Manager 2
- CMB-SP PM 1, a self-priming pump with a pressure control unit, type Pressure Manager 1
- CMB PM 1, a pump with a pressure control unit, type Pressure Manager 1
- CMB PT, a CM pump with a horizontal or vertical pressure tank
- CMB PS, a CM pump with a pressure switch.

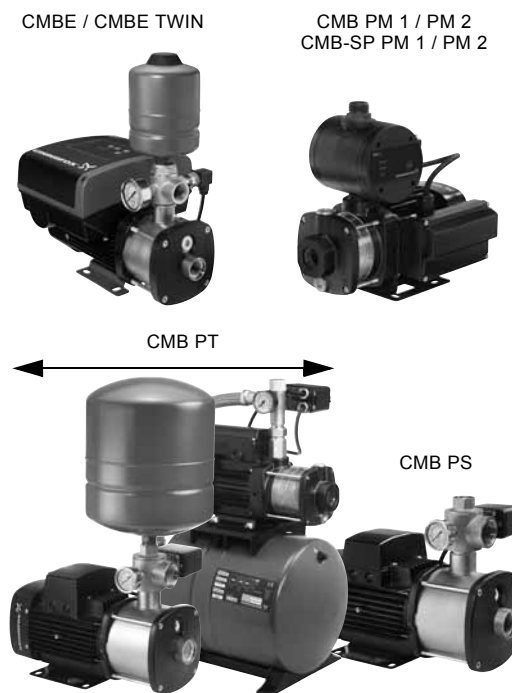

Fig. 1 CMBE / CMBE TWIN, CMB-SP PM 1 / PM 2, CMB PM 1 / PM 2, CMB PT and CMB PS

TM05 7512 3713 - TM04 9362 3713 - TM05 5049 3212 - TM05 9264 3713 - TM05 9265 3713

Applications

The boosters are designed to cover a wide range of applications from small domestic installations to small industrial systems. Typical applications:

- Pressure boosting for home and gardening
- water supply for agriculture and irrigation
- transfer and pressure boosting in break tank and rainwater applications
- water supply from shallow wells
- a twin solution for larger applications, such as apartment buildings, hospitals, hotels and small industrial plants.

Pumped liquids

The boosters are suitable for pumping clean, thin, non-aggressive and non-explosive liquids without solid particles or fibres. Examples:

- Drinking or tap water
- rainwater and condensate
- groundwater
- river and lake water
- boiler feed water and district heating water
- chlorinated water
- softened water
- washing and cleaning.

The pumps must not be used for transfer of diesel oil or other oil-containing liquids. Sand and other impurities in the water can cause wear to the pump.

Identification

Type key

Example	CMBE	1	- 47	- I	- K	- A	- C	- D	- A
Type range									
CMBE TWIN:	CMBE TWIN Booster with cascade control and pump alternation								
CMBE:	CMBE Booster with integrated frequency converter								
CMB-SP SET PM 2:	CM Booster, self-priming, with PM 2 - Maximum suction lift 8 m								
CMB-SP PM 2:	CM Booster, self-priming, with PM 2 - Maximum suction lift 4 m								
CMB-SP SET PM 1:	CM Booster, self-priming, with PM 1 - Maximum suction lift 8 m								
CMB-SP PM 1:	CM Booster, self-priming, with PM 1 - Maximum suction lift 4 m								
CMB PT:	CM Booster with pressure switch and tank								
CMB PS:	CM Booster with pressure switch								
Rated flow rate									
At 50 Hz [m ³ /h]									
Maximum head									
[m]									
Materials in contact with the pumped liquid									
A: Inlet and outlet parts	EN-GJL-200								
Pump shaft	EN 1.4301/AISI 304								
Impellers/chambers	EN 1.4301/AISI 304								
Pressure manager	PP 30GF								
Pressure tank	EPDM/steel/PP/Butyl								
5-way valve	EN 1.4301/AISI 304								
I: Sleeve	EN 1.4301/AISI 304								
Pump shaft	EN 1.4301/AISI 304								
Impellers/chambers	EN 1.4301/AISI 304								
Pressure manager	PP 30GF								
Pressure tank	EPDM/steel/PP/Butyl								
5-way valve	EN 1.4301/AISI 304								
Supply voltage									
A: 1 x 220 V, 60 Hz									
C: 1 x 220-240 V, 50 Hz									
K: 1 x 200-240 V, 50/60 Hz									
F: 3 x 230/400 V, 50 Hz									
U: 1 x 200-240 V, 50/60 Hz ¹⁾									
Motor									
A: Standard motor (IP55)									
C: High-efficiency motor with frequency converter (IP55)									
Main cable and plug									
A: 1.5 m cable with Australian plug									
B: 1.5 m cable with US plug									
C: 1.5 m cable with Schuko plug									
D: 1.5 m cable without plug									
E: No cable, no plug									
G: 1.5 m cable with UK plug									
I: 1.5 m cable without plug									
Controller									
A: PM 1-15 (1.5 bar)									
B: PM 1-22 (2.2 bar)									
C: PM 2									
D: Integrated frequency converter									
G: Integrated frequency converter with inlet pressure switch									
N: Integrated frequency converter with inlet pressure switch (KIWA-ATA approved)									
P: Pressure switch									
Thread									
A: RP 1									
B: RP 1 1/4									
C: RP 1 1/2									
D: RP 2									
E: NPT 1									
F: NPT 1 1/4									
G: NPT 1 1/2									
H: NPT 2									

¹⁾ The new-generation MGE, currently 0.37 to 2.2 kW.

Note: The type key cannot be used for ordering as not all combinations are possible.

Installation

Mechanical installation

Placing the pump above ground is generally a convenient way of establishing a water or rainwater supply.

Place the pump as close as possible to the water supply to make the inlet pipe as short as possible.

If a hose is used as inlet pipe, it must be non-collapsible. Fit a strainer to the inlet pipe to prevent solids from entering the pump.

The pump must be installed on a plane and solid surface and fixed so that it cannot be displaced during startup and operation. The inlet direction must be horizontal.

The pump must be installed with easy access for inspection, maintenance and service.

The pump must be installed in a well-ventilated location. When installed outdoors, the booster must be provided with a suitable cover. The cover must be sufficiently large to ensure that the motor is not exposed to direct sunlight, rain or snow. Inlet pipe
If the pump is to pump water from a well, borehole or similar, always fit a non-return valve on the inlet pipe of the pump.

The length of the inlet pipe of self-priming pumps must not exceed the length stated in fig. 2. The maximum length depends on the geodetic suction lift. As shown in the example below, if the suction lift is 2.5 m, then the length of the inlet pipe must not exceed 25 m.

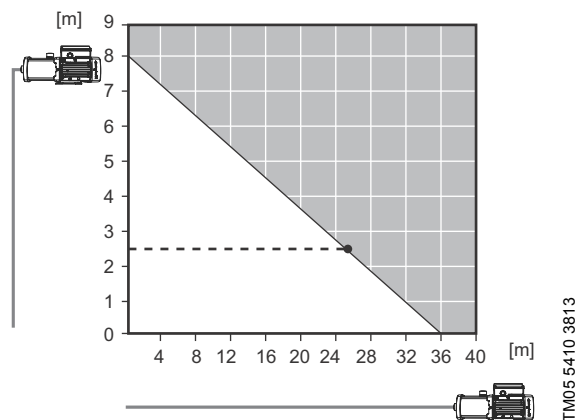

Fig. 2 Recommended maximum suction lift or maximum inlet pipe length (Y-axis)

Install the inlet pipe in such a way that bends, airlocks and any unnecessary restrictions to the flow are avoided. See fig. 3.

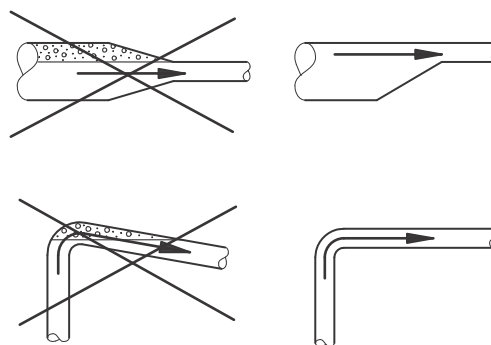

Fig. 3 Pipe recommendations

Long inlet pipes affect the performance of the pump. The diameter of the inlet pipe must not be smaller than that of the inlet port. When the inlet pipe is longer than 10 metres or the suction lift is greater than 4 metres, the diameter of the inlet pipe must be larger than that of the inlet port.

The time from when the pump is started until it delivers water depends on the length of the inlet pipe and on the suction lift. Do not allow the pump to run for more than five minutes before it delivers water as the heat generated will damage the pump.

TM04 0438 0608

TM05 5410 3813

Self-priming CM Booster sets

Note: The following applies only to self-priming CM Boosters delivered as sets.

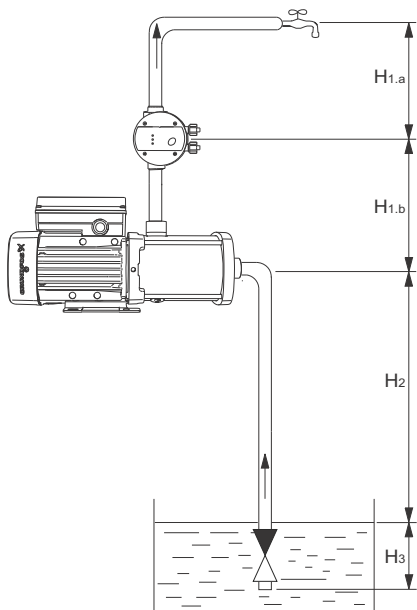

TM05 9410 3813

Fig. 4 Self-priming CM Booster

The length H_{1,b} of the outlet pipe must be minimum 0.2 metres. See fig. 4. By increasing H_{1,b}, a suction lift up to 8 metres can be achieved. Use the table below to determine the necessary outlet pipe length for your desired suction lift.

Outlet pipe length H _{1,b} [m]	Resulting suction lift H ₂ [m]
≥ 0.35	5
≥ 0.5	6
≥ 0.6	7
≥ 0.7	8

Install the pressure manager on the outlet side of the pump. It incorporates a non-return valve.

We recommend to install the unit so that the height between the unit and the highest tapping point, H_{1,a}, does not exceed the values in the table below. See fig. 4.

Pressure manager	Start pressure [bar]	Maximum height H _{1,a} [m]
PM 1-15	1.5	10
PM 1-22	2.2	17
PM 2	1.5	11
	2	16
	2.5	21
	3	26
	3.5	31
	4	36
	4.5	41
	5	46

Operating conditions

The maximum time of operation against a closed outlet valve is limited by the liquid temperature which must not exceed +40 °C (104 °F).

The maximum inlet pressure depends on the pump head at the actual duty point. The sum of the inlet pressure and the pump head must not exceed the maximum system pressure.

Electrical installation

The electrical connection and protection must be carried out in accordance with local regulations.

- The pump must be connected to an external main switch with a minimum contact gap of 3 mm in all poles.
- Make sure that the pump and the pressure control unit are suitable for the power supply to which they are to be connected.
- The pump and pressure control unit must always be correctly earthed.
- Single-phase standard Grundfos Boosters incorporate thermal protection and therefore require no external protection.
- Single-phase Grundfos Boosters require no external motor protection. The variable-speed motor incorporates thermal protection against slow overloading and blocking.
- Three-phase Grundfos Boosters require external motor protection in accordance with local regulations. The electrical installation of the pressure control unit must be carried out so that the enclosure class is maintained.

Selection guide for residential applications

The following instructions primarily target residential applications. This is a quick and easy guide to show you which product is ideal for your needs. Follow the charts and instructions and you will be sure to get a perfect fit.

Example: Sizing and selection

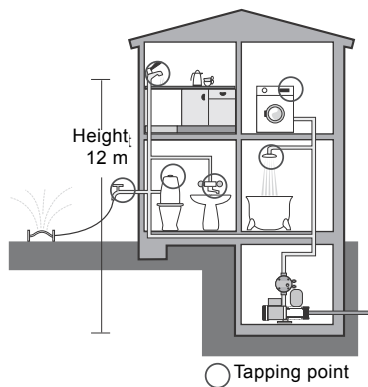

- A: Required comfort level**
- Adjustable constant pressure.
- B: Find the right booster**
- How many taps? 6.
 - How many floors? 3.
- Result: CMBE 1-75**

TM05 9319 3713

Number of floors	Number of taps			
	1-5	6-10	11-20	21-50
4	CMBE 1-75	CMBE 1-75	CMBE 3-62	CMBE 3-93
3	CMBE 1-44	CMBE 1-75	CMBE 3-62	CMBE 3-62
2	CMBE 1-44	CMBE 1-44	CMBE 3-62	CMBE 3-62
1	CMBE 1-44	CMBE 1-44	CMBE 3-30	CMBE 3-62

Fig. 5 Sizing and selection

Booster sizing and selection

Comfort

Variable speed control



- Adjustable constant pressure
- Dry-running protection
- Low-noise

CMBE Booster

Number of floors	Number of taps			
	1-5	6-10	11-20	21-50
4	CMBE 1-75	CMBE 1-75	CMBE 3-62	CMBE 3-93
3	CMBE 1-44	CMBE 1-75	CMBE 3-62	CMBE 3-62
2	CMBE 1-44	CMBE 1-44	CMBE 3-62	CMBE 3-62
1	CMBE 1-44	CMBE 1-44	CMBE 3-30	CMBE 3-62

Conventional pump control



- Compact design
- Dry-running protection
- Easy installation

CM Booster

Conventional pump control



- Self-priming
- Low-noise
- Dry-running protection

CM Booster SP

Conventional pump control



- Adjustable pressure level
- Minimum pump operation

PT Booster

Number of floors	Number of taps			
	1-5	6-10	11-20	21-50
4	CMB 1-54	CMB 3-47	CMB 3-47	CMB 5-47
3	CMB 1-45	CMB 3-37	CMB 3-47	CMB 5-47
2	CMB 1-45	CMB 3-37	CMB 3-47	CMB 5-38
1	CMB 1-36	CMB 3-28	CMB 3-37	CMB 5-38

Add an extra floor when the booster is used for a suction lift higher than 4 metres

- Adjustable start pressure
- Pressure read-out
- Cycling protection
- Max. run time stop
- Auto-reset

CMB PM 2
Max. height, adjustable [m]: 11-45

CMB PM 1-22
Max. height [m]: 18

CMB PM 1-15
Max. height [m]: 11

Preconditions:

- A tap pressure of 3 bar is considered, to achieve a pressure of 4 bar, add two floors.
- If the inlet is flooded: In suction operation (CM booster SP) add more floors to compensate for head loss.
- 0.5 l/s per tap average usage pattern is taken into account.

Grundfos cannot be held responsible for wrong sizing based on this guide.

Selection guide for commercial applications

The following instructions primarily target commercial applications.

The CMBE TWIN Booster is the recommended product for commercial applications in large buildings, small industrial plants and businesses, agriculture and irrigation. See examples and calculations below.

Note: Local legislation must always be taken into account.

Flow rate

The total consumption and the required maximum flow rate depend on the application in question. The required maximum flow rate can be calculated by means of the table below which is based on statistical data.

Consumer	Unit [n]	Q _{year}	Consumption period [d]	Q _{day}	fd*	Q (m) _{day}	ft**	Max. flow rate
		m ³ /year	days/year	m ³ /day		m ³ /day		m ³ /h
Residence building	Residents (2.5 persons)	183	365	0.5	1.3	0.65	1.7	0.046
Office building	Employee	25	250	0.1	1.2	0.12	3.6	0.018
Shopping centre	Employee	25	300	0.08	1.2	0.1	4.3	0.018
Supermarket	Employee	80	300	0.27	1.5	0.4	3.0	0.05
Hotel	Bed	180	365	0.5	1.5	0.75	4.0	0.125
Hospital	Bed	300	365	0.8	1.2	1.0	3.0	0.12
School	Pupil	8	200	0.04	1.3	0.065	2.5	0.007

* fd: Maximum consumption factor per day.

** ft: Maximum consumption factor per hour.

Example: Hotel with 540 beds

- Number of beds: n.
- Total annual consumption: Q_{year} x n.
- Consumption period: d.
- Average consumption per day: (Q_{year} x n)/d.
- Maximum consumption per day: Q(m)_{day} = fd x Q_{day}.
- Required maximum flow rate per hour: Q_{max} = maximum flow rate/hour x number of beds.

Calculation

- n = 540 beds.
- Q_{year} x n = 180 x 540 = 97,200 m³/year.
- d = 365 days/year.
- (Q_{year} x n)/d = 97,200/365 = 266.3 m³/day.
- Q(m)_{day} = fd x Q_{day} = 1.5 x 266.3 = 399.4 m³/day.
- Q_{max} = maximum flow rate/hour x number of beds = 0.125 x 540 = 67.5 m³/h.

2. CMBE TWIN

CMBE TWIN Booster



Fig. 6 CMBE TWIN Booster

TM06 8671 1017

Applications

The compact Grundfos CMBE TWIN Booster is suitable for clean water supply and pressure boosting in domestic and commercial applications. The CMBE TWIN Booster keeps a constant pressure in the pipe system and is mainly used in places such as:

- two-family houses
- cluster homes
- blocks of flats
- schools
- small hotels
- small office buildings
- small industrial plants and businesses
- hospitals
- agriculture and irrigation.

Product Description

The CMBE TWIN Booster system consists of two CMBE Boosters connected in parallel and mounted on a common base plate.

Accessories:

- vibration dampers (PN 99217259)
- inlet/outlet pipes with ball valve and unions and 1 1/2" outlet connection.
(PN 99229422 for 1" inlet connection)
(PN 99229453 for 1 1/4" inlet connection)

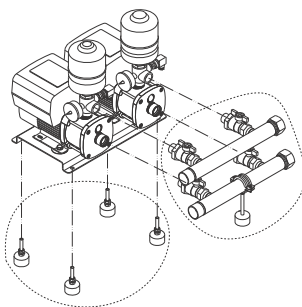

Fig. 7 Accessories

TM06 8740 1017

Motor

No external motor protection is required. The MGE motor incorporates thermal protection against slow overloading and blocking (TP 211 according to IEC 34.11).

Features

- Constant pressure via integrated speed control
- cascade control and pump alternation
- dry-running protection
- compact
- robust, stainless steel design
- easy installation
- low energy consumption
- noise level below 55 dBA and even lower at controlled speed.

Constant pressure

The integrated speed controller keeps a constant pressure in the pipe system. A pressure sensor monitors changes in the water consumption and signals to the speed controller to adjust the motor speed up or down.

Cascade control

Cascade control ensures that the performance of the booster system is automatically adapted to the consumption by switching pumps on or off and by changing the speed of the pumps in operation. The system runs as energy-efficiently as possible with a constant pressure and only the number of pumps required.

Pump alternation

Pump alternation ensures that the operating hours are distributed evenly on the pumps over time. CMBE TWIN Booster automatically alternates the pumps and will start the available pump with the lowest number of running hours since the last time the power was switched off.

Dry-running protection

Dry-running protection is very important as dry running may damage the bearings and shaft seals. Lack of inlet pressure or water shortage is indicated by the motor speed. When dry running is detected, the CMBE Booster will stop and go into alarm mode.

Easy installation

The booster is easy to install. When the booster has been connected to the pipes, it is all a matter of plugging the plug into a socket, and the system is operational.

Operating conditions

System pressure	Max. 10 bar.
Suction lift	Max. 1 m, including suction-pipe pressure loss at a liquid temperature of +20 °C.
Liquid temperature	0-60 °C.
Ambient temperature	Max. +55 °C. Min. -20 °C.
Relative humidity	Max. 95 %.
Enclosure class	IP55.
Insulation class	F.
Sound pressure level	The sound pressure level of the pump is below 55 dB(A).
Supply voltage	1 x 200-240 V, 50/60 Hz.
Start/stop frequency	Max. 100 per hour.
Cut-in pressure	0.5 bar below setpoint.

Electrical data

Pump type	Voltage [V]	I _{max} [A]	P ₁ [W]	Plug type
CMBE 3-30	1 x 200-240	6.7 - 5.6	688	Schuko or fuse box
CMBE 3-62	1 x 200-240	6.7 - 5.6	1210	
CMBE 3-93	1 x 200-240	9.1 - 7.6	1720	
CMBE 5-31	1 x 200-240	6.7 - 5.6	1090	
CMBE 5-62	1 x 200-240	9.1 - 7.6	1720	

Approvals

The product is built according to European drinking water approvals.

Wetted parts

The table below specifies the parts of the pump that are in contact with the pumped liquid.

Designation	Material	Technical description
Pump sleeve	Stainless steel	EN 1.4301 AISI 304
Impeller	Stainless steel	EN 1.4301 AISI 304
Diffuser	Technopolymer	PP 20 % Talc
Ejector	Technopolymer	PPE/PS 20 % GF
Nozzle	Stainless steel	EN 1.4301 AISI 304
Shaft	Stainless steel	EN 1.4301 AISI 304
Shaft seal	Carbon with resin/ceramic	CVBP
Filling plug	Technopolymer	PES 30 % GF
Drain plug	Technopolymer	PES 30 % GF

Dimensional drawings

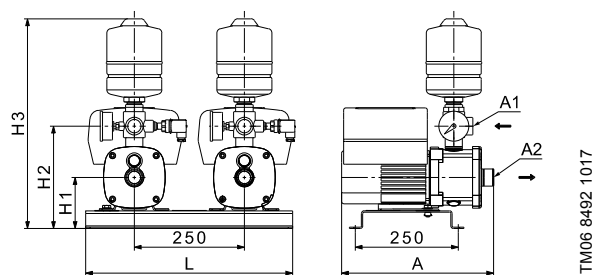

Pump type	H3	H2	H1	L	A	A1 [inch]	A2 [inch]
CMBE 3-30	485	235	110	475	330	1	1
CMBE 3-62	485	235	110	475	344	1	1
CMBE 3-93	495	250	125	475	404	1	1
CMBE 5-31	485	235	110	475	326	1	1 1/4
CMBE 5-62	495	250	125	475	350	1	1 1/4

Control panel

The control panel on the pump terminal box makes it possible to change the setpoint settings manually. The operating condition of the pump is indicated by the Grundfos Eye on the control panel. See fig. 8, pos. A.

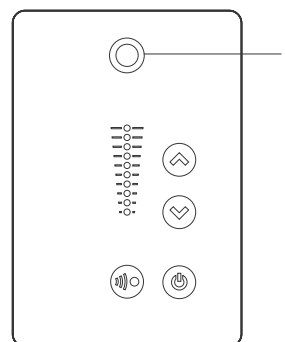
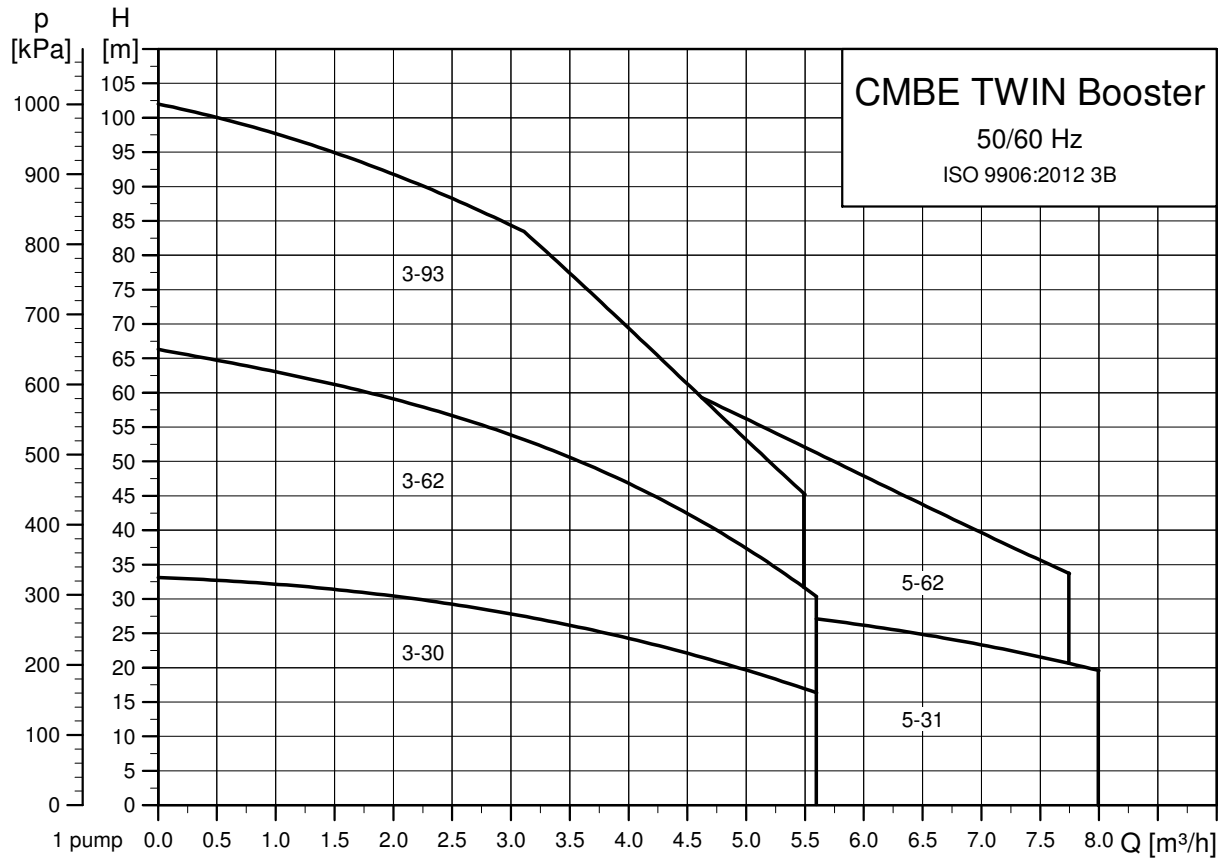

Fig. 8 Control panel

Set the desired setpoint by pressing ⏴ or ⏵. The light fields on the control panel will indicate the setpoint set. Continuously pressing ⏵ will stop the pump. Pressing ⏴ will enable infrared communication with the Grundfos GO Remote and with other products of same type using infrared.

Performance curves



TM06 8495 0817

3. CMBE

CMBE Booster



TM05 7512 3713

Fig. 9 CMBE Booster

Applications

The compact Grundfos CMBE Booster is suitable for clean water supply and pressure boosting in domestic and light commercial applications.

The CMBE Booster keeps a constant pressure in the pipe system and is mainly used in places such as:

Application	CMBE 1	CMBE 3	CMBE 5	CMBE 10
Single-family houses	•	•	○	○
Two-family houses	○	•	•	•
Cluster homes		•	•	•
Blocks of flats		•	•	•
Schools		•	•	•
Small hotels/guest houses		•	•	•
Small office buildings		•	•	•
Agriculture		○	•	•
Irrigation		○	•	•

- Recommended
- Applicable.

Product Description

The CMBE Booster consists of these components:

- CMBE pump with integrated frequency converter
- 5-way fitting with non-return valve
- diaphragm tank
- pressure gauge
- pressure sensor
- inlet pressure switch (optional).

Motor

No external motor protection is required. The MGE motor incorporates thermal protection against slow overloading and blocking (TP 211 according to IEC 34.11).

Features

- Constant pressure via integrated speed control
- dry-running protection
- compact
- robust, stainless steel design
- easy installation
- low energy consumption
- noise level below 55 dBA and even lower at controlled speed.

Constant pressure

The integrated speed controller keeps a constant pressure in the pipe system. A pressure sensor monitors changes in the water consumption and signals to the speed controller to adjust the motor speed up or down.

Dry-running protection

Dry-running protection is very important as dry running may damage the bearings and shaft seals. The inlet pressure of the system or the water level in a possible tank on the inlet side is monitored. Lack of inlet pressure or water shortage is indicated by the motor speed. When dry running is detected, the CMBE Booster will stop and go into alarm mode.

Easy installation

The booster is easy to install. When the booster has been connected to the pipes, it is all a matter of plugging the plug into a socket, and the system is operational.

Operating conditions

System pressure	Max. 10 bar.
Suction lift	Max. 1 m, including suction-pipe pressure loss at a liquid temperature of +20 °C.
Liquid temperature	0-60 °C.
Ambient temperature	Max. +55 °C. Min. -20 °C.
Relative humidity	Max. 95 %.
Enclosure class	IP55.
Insulation class	F.
Sound pressure level	The sound pressure level of the pump is below 55 dB(A).
Supply voltage	1 x 200-240 V, 50/60 Hz.
Start/stop frequency	Max. 100 per hour.
Cut-in pressure	0.5 bar below setpoint.

Electrical data

Pump type	Voltage [V]	I _{max} [A]	P1 [W]	Plug type
CMBE 1-44	1 x 200-240	3.45 - 2.9	615	Schuko, US, AU, UK or without plug
CMBE 1-75	1 x 200-240	6.7 - 5.6	998	
CMBE 1-99	1 x 200-240	6.7 - 5.6	1250	
CMBE 3-30	1 x 200-240	6.7 - 5.6	688	
CMBE 3-62	1 x 200-240	6.7 - 5.6	1210	
CMBE 3-93	1 x 200-240	9.1 - 7.6	1720	
CMBE 5-31	1 x 200-240	6.7 - 5.6	1090	
CMBE 5-62	1 x 200-240	9.1 - 7.6	1720	
CMBE 10-54	1 x 200-240	9.1 - 7.6	1710	

Approvals

The product is built according to European drinking water approvals.

Wetted parts

The table below specifies the parts of the pump that are in contact with the pumped liquid.

Designation	Material	Technical description
Pump sleeve	Stainless steel	EN 1.4301 AISI 304
Impeller	Stainless steel	EN 1.4301 AISI 304
Diffuser	Technopolymer	PP 20 % Talc
Ejector	Technopolymer	PPE/PS 20 % GF
Nozzle	Stainless steel	EN 1.4301 AISI 304
Shaft	Stainless steel	EN 1.4301 AISI 304
Shaft seal	Carbon with resin/ceramic	CVBP
Filling plug	Technopolymer	PES 30 % GF
Drain plug	Technopolymer	PES 30 % GF

Dimensional drawings

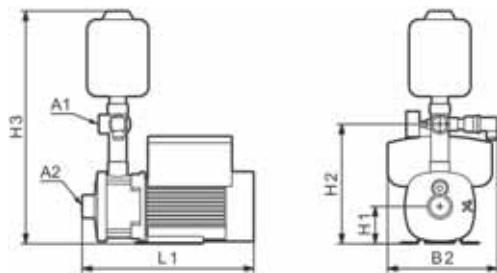

TM06 0802 0914

Pump type	H3	H2	H1	L1	B2	A1 [inch]	A2 [inch]
CMBE 1-44	440	200	75	326	217	1	1
CMBE 1-75	440	200	75	362	217	1	1
CMBE 1-99	440	200	75	398	217	1	1
CMBE 3-30	440	200	75	326	217	1	1
CMBE 3-62	440	200	75	344	217	1	1
CMBE 3-93	455	215	90	404	217	1	1
CMBE 5-31	440	200	75	326	217	1	1 1/4
CMBE 5-62	455	215	90	350	217	1	1 1/4
CMBE 10-54	510	253	92	377	232	1 1/2	1 1/2

Materials

Designation	Material
Terminal box	Composite PC/ASA and silumin (Alu)
Stator housing	Silumin (Alu)
Fan cover	Composite PBT/PC
Pump housing	Stainless steel, EN 1.4301/AISI 304
Shaft and impeller	Stainless steel, EN 1.4301/AISI 304
Flange	Cast iron

Control panel

The control panel on the E-pump terminal box makes it possible to change the setpoint settings manually.

The operating condition of the pump is indicated by the Grundfos Eye on the control panel. See fig. 10, pos. A.

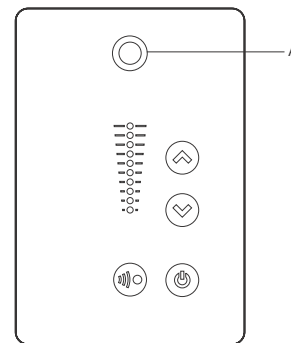

TM05 5993 4312

Fig. 10 Control panel

Set the desired setpoint by pressing ☺ or ☹. The light fields on the control panel will indicate the setpoint set. Continuously pressing ☹ will stop the pump.

Pressing ☺ will enable infrared communication with the Grundfos GO Remote and with other products of same type using infrared.

Performance curves

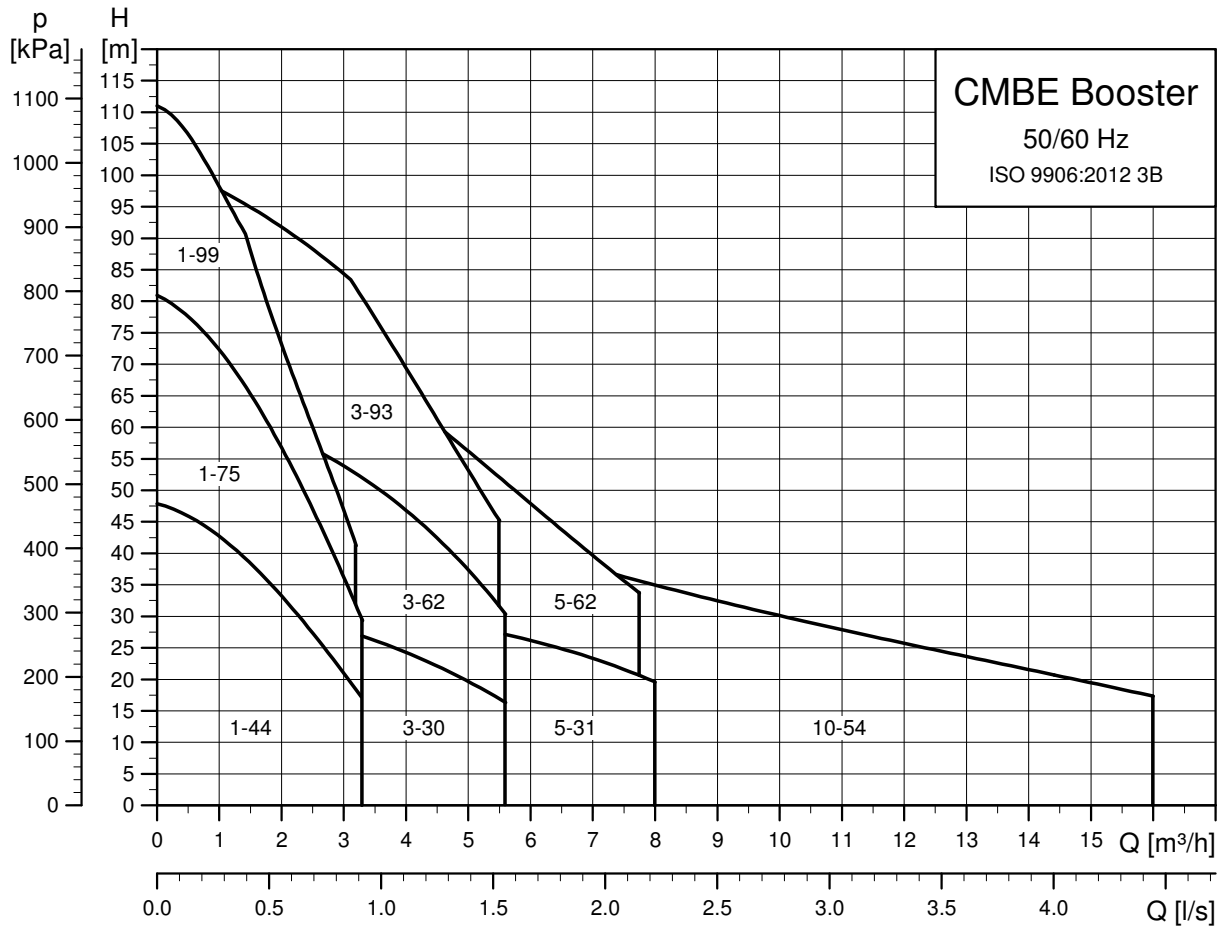

TM06 1039 0817

4. CMB-SP PM 2

CM Booster Self-Priming Pressure Manager 2



TM04 9361 3813

Fig. 11 CM Booster PM 2

The self-priming Grundfos CM Booster supplied with a PM 2 pressure manager is a compact booster for water supply in domestic applications. The pressure manager allows the pump to start and stop automatically according to demand and protects the pump from dry running.

The CM Booster is very easy to install. When the booster has been connected to the pipes, it is all a matter of plugging the plug into a socket, and the system is operational.

Applications

Grundfos self-priming CM PM 1 Booster is mainly used for domestic and light commercial water supply or booster systems.

Application	CMB1	CMB3	CMB5
Single-family houses	●	●	○
Two-family houses	○	●	●
Cluster homes		●	●
Blocks of flats		●	●
Schools		●	●
Small hotels/guest houses		●	●
Small office buildings		●	●

- Recommended
- Applicable.

Motor

CM Booster pumps have built-in current- and temperature-dependent motor protection in accordance with IEC 60034-11 and require no further motor protection.

Features

- Compact
- self-priming within five minutes
- easy installation
- dry-running protection
- anti cycling (leakage detection).

Versions

CMB-SP is available in two versions:

- Standard version with pressure manager factory mounted on the pump. This version allows a suction lift of maximum 4 m.
- Kit version, called CMB-SP SET, without pressure manager mounted on the pump. This version allows a suction lift of maximum 8 m if there is a pipe between the pump and the pressure manager of at least 0.7 m. The kit version is capable of suction lift between 0 and 8 m depending on the pipe length between pump and pressure manager.

Operating conditions

System pressure	Max. 10 bar.
Suction lift (H2) See fig. 4 page 7	0 < H2 ≤ 4 m (standard version). 4 < H2 ≤ 8 m (Set version). Including suction-pipe pressure loss at a liquid temperature of +20 °C.
Liquid temperature	0-60 °C.
Ambient temperature	Max. +55 °C. Min. -20 °C.
Relative humidity	Max. 95 %.
Enclosure class	IP55.
Insulation class	F.
Sound pressure level	The sound pressure level of the pump is below 55 dB(A). Note: During priming the sound level may be higher.
Supply voltage	1 x 220-240 V, 50 Hz.
Start/stop frequency	Max. 100 per hour.
Cut-in pressure	1.5 - 5 bar (adjustable).

Electrical data

Pump type	Voltage [V]	I _{max} [A]	P1 [W]	Plug type
CMB-SP 1-27	1 x 220-240	2.4 - 1.8	377	Schuko, AU or without plug
CMB-SP 1-36	1 x 220-240	3.1 - 2.8	400	
CMB-SP 1-45	1 x 220-240	3.1 - 2.8	477	
CMB-SP 1-54	1 x 220-240	3.1 - 2.8	560	
CMB-SP 3-28	1 x 220-240	3.1 - 2.8	490	
CMB-SP 3-37	1 x 220-240	3.1 - 2.8	587	
CMB-SP 3-47	1 x 220-240	3.1 - 2.8	753	
CMB-SP 3-56	1 x 220-240	4.4 - 4.0	867	
CMB-SP 5-28	1 x 220-240	3.1 - 2.8	684	
CMB-SP 5-47	1 x 220-240	5.4 - 5.0	1170	

Approvals

The product is built according to European drinking water approvals.

Wetted parts

The table below specifies the parts of the pump that are in contact with the pumped liquid.

Designation	Material	Technical description
Pump sleeve	Stainless steel	EN 1.4301 AISI 304
Impeller	Stainless steel	EN 1.4301 AISI 304
Diffuser	Technopolymer	PP 20 % Talc
Ejector	Technopolymer	PPE/PS 20 % GF
Nozzle	Stainless steel	EN 1.4301 AISI 304
Shaft	Stainless steel	EN 1.4301 AISI 304
Shaft seal	Carbon with resin/ceramic	CVBP
Filling plug	Technopolymer	PES 30 % GF
Drain plug	Technopolymer	PES 30 % GF

Dimensional drawings

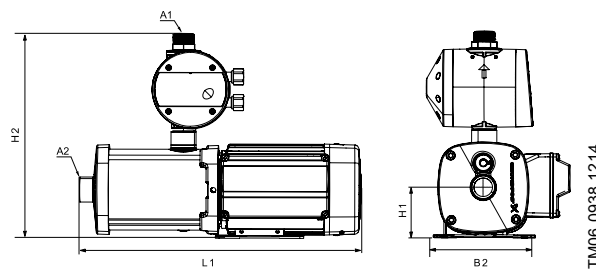

Pump	A1 [inch]	A2 [inch]	L1	B2	H1	H2
CMB-SP 1-27	1	1	377	158	75	317
CMB-SP 1-36	1	1	377	158	75	317
CMB-SP 1-45	1	1	413	158	75	317
CMB-SP 1-54	1	1	413	158	75	317
CMB-SP 3-28	1	1	377	158	75	317
CMB-SP 3-37	1	1	377	158	75	317
CMB-SP 3-47	1	1	413	158	75	317
CMB-SP 3-56	1	1	453	158	75	317
CMB-SP 5-28	1	1	377	158	75	317
CMB-SP 5-47	1	1	453	158	75	317

Performance curves

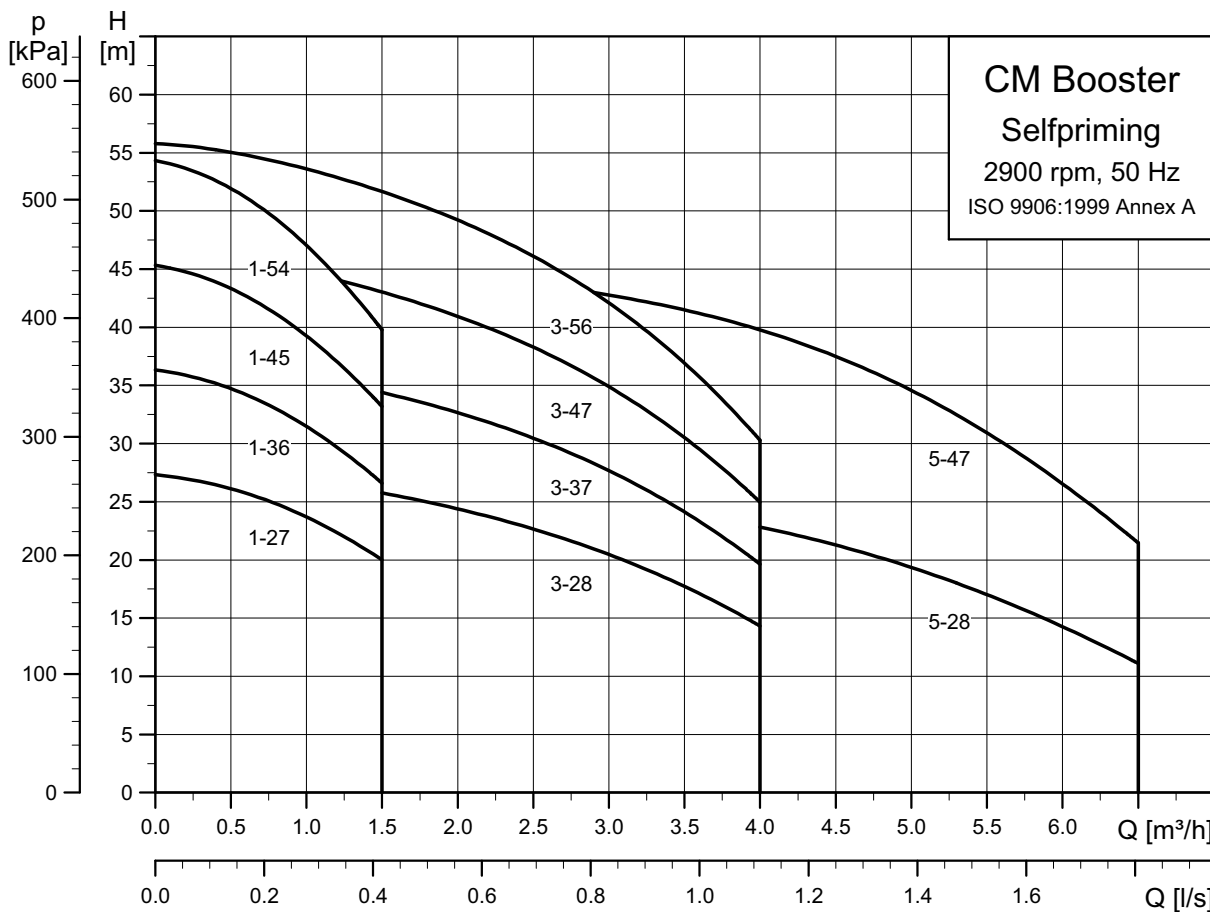

TM06 1042 1414

5. CMB PM 2

CM Booster Pressure Manager 2



TM04 9363 3813 - TM04 9361 3813

Fig. 12 CM Booster PM 2

The compact Grundfos CM Booster with a PM 2 pressure manager is suitable for water supply in domestic applications. The CM pump is available with a stainless-steel and cast iron pump housing. The pressure manager allows the pump to start and stop automatically according to demand and protects the pump from dry running.

The CM Booster is very easy to install. When the booster has been connected to the pipes, it is all a matter of plugging the plug into a socket, and the system is operational.

Applications

Grundfos CM PM 2 Booster is mainly used for domestic and light commercial water supply or booster systems.

Application	CMB1	CMB3	CMB5
Single-family houses	●	●	○
Two-family houses	○	●	●
Cluster homes		●	●
Blocks of flats		●	●
Schools		●	●
Small hotels/guest houses		●	●
Small office buildings		●	●

- Recommended
- Applicable.

Motor

CM Booster pumps have built-in current- and temperature-dependent motor protection in accordance with IEC 60034-11 and require no further motor protection.

Features

- Compact
- easy installation
- automatic resetting of alarms
- dry-running protection
- anti cycling (leakage detection)
- maximum continuous operating time.

Operating conditions

System pressure	Max. 10 bar.
Suction lift	Max. 1 m, including suction-pipe pressure loss at a liquid temperature of +20 °C.
Liquid temperature	0-60 °C.
Ambient temperature	Max. +55 °C. Min. -20 °C.
Relative humidity	Max. 95 %.
Enclosure class	IP55.
Insulation class	F.
Sound pressure level	The sound pressure level of the pump is below 55 dB(A).
Supply voltage	1 x 220-240 V, 50 Hz.
Start/stop frequency	Max. 100 per hour.
Cut-in pressure	1.5 - 5 bar (adjustable).

Electrical data

Pump type	Voltage [V]	I _{max} [A]	P ₁ [W]	Plug type
CMB 1-27	1 x 220-240	2.4 - 1.8	377	Schuko, US, AU, without plug
CMB 1-36	1 x 220-240	3.1 - 2.8	436	
CMB 1-45	1 x 220-240	3.1 - 2.8	498	
CMB 1-54	1 x 220-240	3.1 - 2.8	568	
CMB 3-28	1 x 220-240	3.1 - 2.8	491	
CMB 3-37	1 x 220-240	3.1 - 2.8	587	
CMB 3-47	1 x 220-240	3.1 - 2.8	689	
CMB 3-56	1 x 220-240	4.4 - 4.0	869	
CMB 5-28	1 x 220-240	3.1 - 2.8	715	
CMB 5-47	1 x 220-240	5.4 - 5.0	1160	
CMB 5-38	1 x 220-240	4.4 - 4.0	869	AU

Approvals

The booster is built according to European drinking water approvals.

Wetted parts

The table below specifies the parts of the pump that are in contact with the pumped liquid.

Designation	Material	Technical description
Pump sleeve	Stainless steel	EN 1.4301 AISI 304
Impeller	Stainless steel	EN 1.4301 AISI 304
Diffuser	Technopolymer	PP 20 % Talc
Ejector	Technopolymer	PPE/PS 20 % GF
Nozzle	Stainless steel	EN 1.4301 AISI 304
Shaft	Stainless steel	EN 1.4301 AISI 304
Shaft seal	Carbon with resin/ceramic	CVBP
Filling plug	Technopolymer	PES 30 % GF
Drain plug	Technopolymer	PES 30 % GF

Dimensional drawings

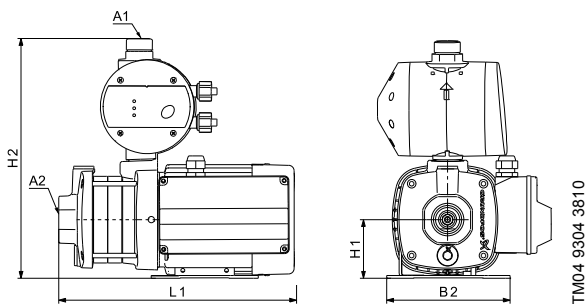

Pump type	A1 [inch]	A2 [inch]	L1	B2	H1	H2
Cast Iron						
CMB 1-27	1	1	305	158	75	317
CMB 1-36	1	1	323	158	75	317
CMB 1-45	1	1	341	158	75	317
CMB 1-54	1	1	377	158	75	317
CMB 3-28	1	1	305	158	75	317
CMB 3-37	1	1	323	158	75	317
CMB 3-47	1	1	341	158	75	317
CMB 3-56	1	1	417	158	75	317
CMB 5-28	1	1 1/4	305	158	75	317
CMB 5-38	1	1 1/4	363.5	158	75	317
CMB 5-47	1	1 1/4	381	158	75	317
Stainless steel						
CMB 1-27	1	1	305	158	75	317
CMB 1-36	1	1	323	158	75	317
CMB 1-45	1	1	341	158	75	317
CMB 1-54	1	1	377	158	75	317
CMB 3-28	1	1	305	158	75	317
CMB 3-37	1	1	323	158	75	317
CMB 3-47	1	1	341	158	75	317
CMB 3-56	1	1	417	158	75	317
CMB 5-28	1	1 1/4	305	158	75	317
CMB 5-38	1	1 1/4	363.5	158	75	317
CMB 5-47	1	1 1/4	381	158	75	317

Performance curves

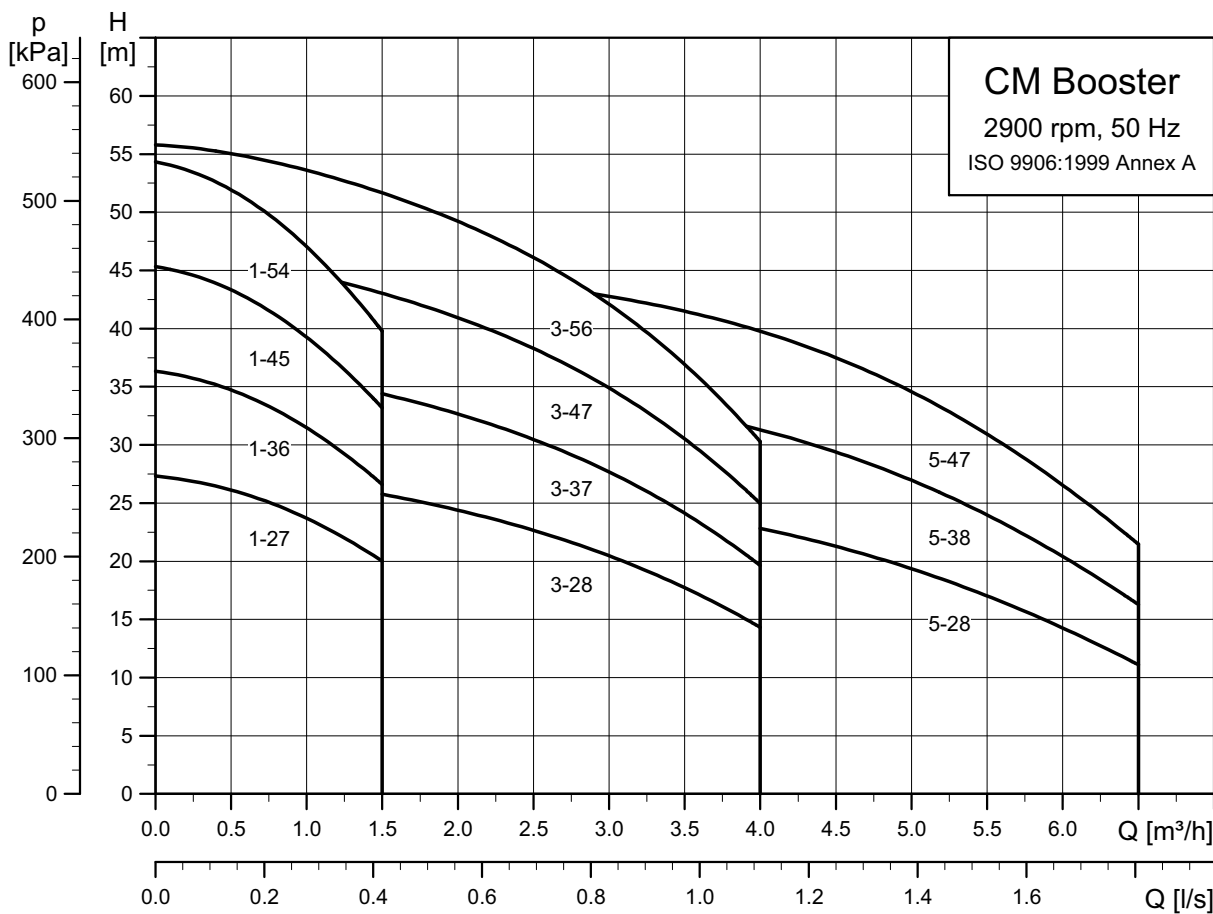

TM06 1282 1514

6. CMB-SP PM 1

CM Booster Self-Priming Pressure Manager 1



TMD4 9362 3813

Fig. 13 CM Booster SP PM 1

The compact self-priming Grundfos CM Booster with a PM 1 pressure manager is suitable for water supply in domestic applications. The pressure manager allows the pump to start and stop automatically according to demand and protects the pump from dry running.

The CM Booster is very easy to install. When the booster has been connected to the pipes, it is all a matter of plugging the plug into a socket, and the system is operational.

Applications

Grundfos self-priming CM PM 1 Booster is mainly used for domestic and light commercial water supply or booster systems.

Application	CMB1	CMB3	CMB5
Single-family houses	•	•	○
Two-family houses	○	•	•
Cluster homes		•	•
Blocks of flats		•	•
Schools		•	•
Small hotels/guest houses		•	•
Small office buildings		•	•

- Recommended
- Applicable.

Motor

CM Booster pumps have built-in current- and temperature-dependent motor protection in accordance with IEC 60034-11 and require no further motor protection.

Features

- Compact
- self-priming within five minutes
- easy installation
- dry-running protection
- anti cycling (leakage detection).

Versions

CMB-SP is available in two versions.

- Standard version with a pressure manager factory mounted on the pump. This version allows a suction lift for maximum 4 m.
- Kit version, called CMB-SP SET, without a pressure manager mounted on the pump. This version allows a suction lift of 4 to 8 m if there is a pipe between the pump and the pressure manager of at least 0.7 m.

Operating conditions

System pressure	Max. 10 bar.
Suction lift (H2) See fig. 4 page 7	0 < H2 ≤ 4 m (standard version). 4 < H2 ≤ 8 m (Set version). Including suction-pipe pressure loss at a liquid temperature of +20 °C.
Liquid temperature	0-60 °C.
Ambient temperature	Max. +55 °C. Min. -20 °C.
Relative humidity	Max. 95 %.
Enclosure class	IP55.
Insulation class	F.
Sound pressure level	The sound pressure level of the pump is below 55 dB(A). Note: During priming the sound level may be higher.
Supply voltage	1 x 220-240 V, 50 Hz.
Start/stop frequency	Max. 100 per hour.
Cut-in pressure	PM 1-15: 1.5 bar. PM 1-22: 2.2 bar.

Electrical data

Pump type	Voltage [V]	I _{max} [A]	P1 [W]	Plug type
CMB-SP 1-27	1 x 220-240	2.4 - 1.8	377	Schuko, AU or without plug
CMB-SP 1-36	1 x 220-240	3.1 - 2.8	400	
CMB-SP 1-45	1 x 220-240	3.1 - 2.8	477	
CMB-SP 1-54	1 x 220-240	3.1 - 2.8	560	
CMB-SP 3-28	1 x 220-240	3.1 - 2.8	490	
CMB-SP 3-37	1 x 220-240	3.1 - 2.8	587	
CMB-SP 3-47	1 x 220-240	3.1 - 2.8	753	
CMB-SP 3-56	1 x 220-240	4.4 - 4.0	867	
CMB-SP 5-28	1 x 220-240	3.1 - 2.8	684	
CMB-SP 5-47	1 x 220-240	5.4 - 5.0	1170	

Approvals

The product is built according to European drinking water approvals.

Wetted parts

The table below specifies the parts of the pump that are in contact with the pumped liquid.

Designation	Material	Technical description
Pump sleeve	Stainless steel	EN 1.4301 AISI 304
Impeller	Stainless steel	EN 1.4301 AISI 304
Diffuser	Technopolymer	PP 20 % Talc
Ejector	Technopolymer	PPE/PS 20 % GF
Nozzle	Stainless steel	EN 1.4301 AISI 304
Shaft	Stainless steel	EN 1.4301 AISI 304
Shaft seal	Carbon with resin/ceramic	CVBP
Filling plug	Technopolymer	PES 30 % GF
Drain plug	Technopolymer	PES 30 % GF

Dimensional drawings

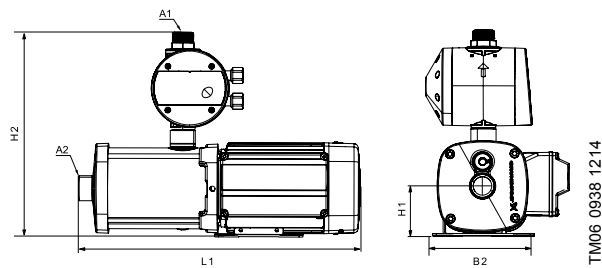

Pump type	A1 [inch]	A2 [inch]	L1	B2	H1	H2
CMB-SP 1-27	1	1	377	158	75	317
CMB-SP 1-36	1	1	377	158	75	317
CMB-SP 1-45	1	1	413	158	75	317
CMB-SP 1-54	1	1	413	158	75	317
CMB-SP 3-28	1	1	377	158	75	317
CMB-SP 3-37	1	1	377	158	75	317
CMB-SP 3-47	1	1	413	158	75	317
CMB-SP 3-56	1	1	453	158	75	317
CMB-SP 5-28	1	1	377	158	75	317
CMB-SP 5-47	1	1	453	158	75	317

Performance curves

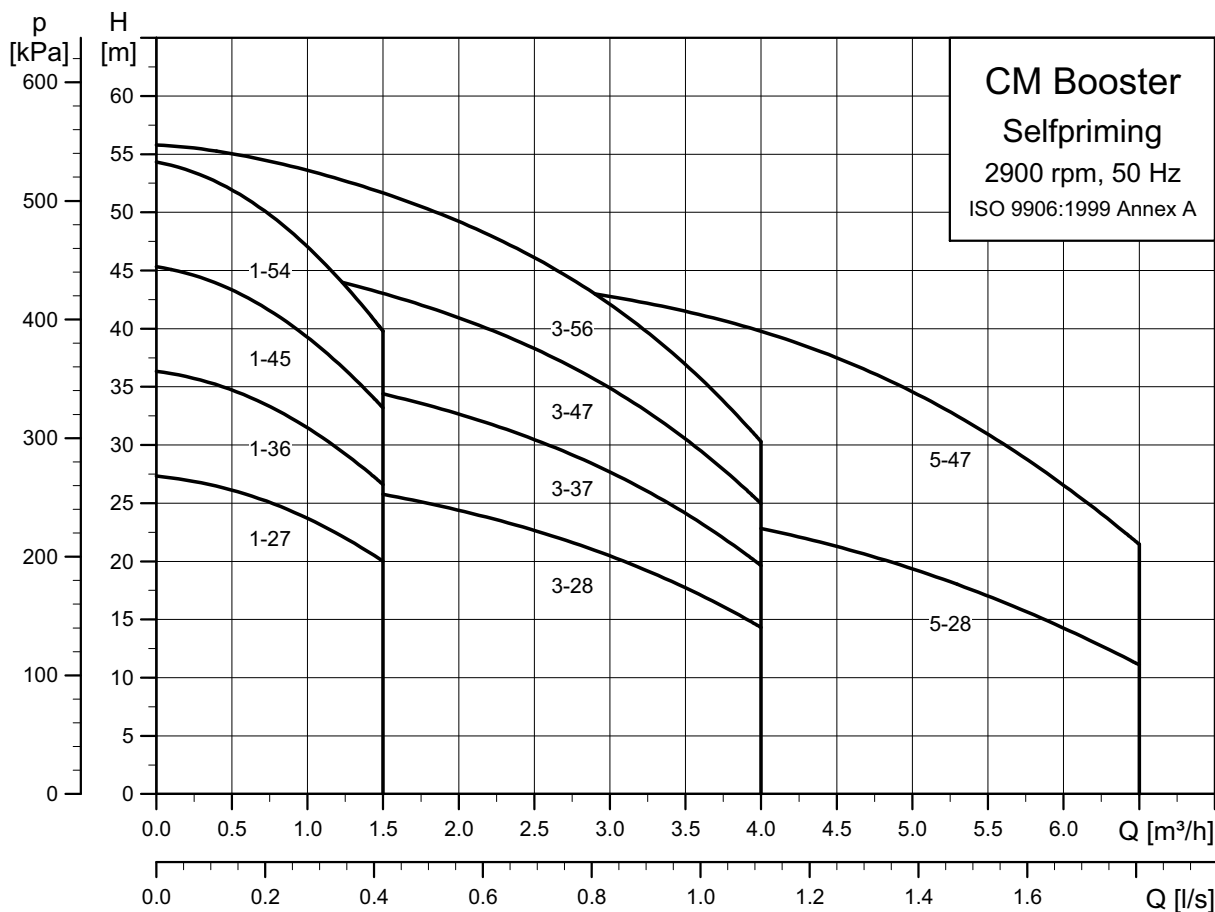

TM06 1042 1414

7. CMB PM 1

CM Booster Pressure Manager 1

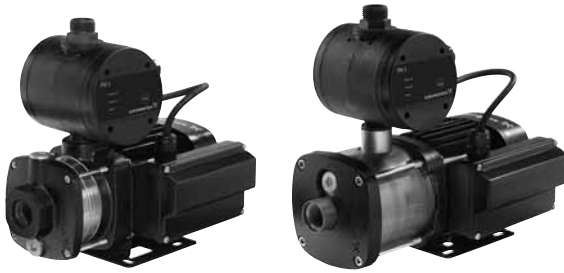

TM04 9362 3813 - TM04 9362 3813

Fig. 14 CM Booster PM 1

The compact Grundfos CM Booster with a PM 1 pressure manager is suitable for water supply in domestic applications. The pressure manager allows the pump to start and stop automatically according to demand and protects the pump from dry running.

The CM Booster is very easy to install. When the booster has been connected to the pipes, it is all a matter of plugging the plug into a socket, and the system is operational.

Applications

Grundfos CM PM 1 Booster is mainly used for domestic and light commercial water supply or booster systems.

Application	CMB1	CMB3	CMB5
Single-family houses	●	●	○
Two-family houses	○	●	●
Cluster homes		●	●
Blocks of flats		●	●
Schools		●	●
Small hotels/guest houses		●	●
Small office buildings		●	●

- Recommended
- Applicable.

Motor

CM pumps have built-in current- and temperature-dependent motor protection in accordance with IEC 60034-11 and require no further motor protection.

Features

- Compact
- easy installation
- dry-running protection
- anti cycling (leakage detection).

Operating conditions

System pressure	Max. 10 bar.
Suction lift	Max. 1 m, including suction-pipe pressure loss at a liquid temperature of +20 °C.
Liquid temperature	0-60 °C.
Ambient temperature	Max. +55 °C. Min. -20 °C.
Relative humidity	Max. 95 %.
Enclosure class	IP44.
Insulation class	F.
Sound pressure level	The sound pressure level of the pump is below 55 dB(A).
Supply voltage	1 x 220-240 V, 50 Hz.
Start/stop frequency	Max. 100 per hour.
Cut-in pressure	PM 1-15: 1.5 bar. PM 1-22: 2.2 bar.

Electrical data, 50 Hz

Pump type	Voltage [V]	I _{max} [A]	P1 [W]	Plug type
CMB 1-27	1 x 220-240	1.8 - 2.4	377	
CMB 1-36	1 x 220-240	3.1 - 2.8	436	
CMB 1-45	1 x 220-240	3.1 - 2.8	498	
CMB 1-54	1 x 220-240	3.1 - 2.8	568	
CMB 3-28	1 x 220-240	3.1 - 2.8	491	Schuko, US, AU, without plug
CMB 3-37	1 x 220-240	3.1 - 2.8	587	
CMB 3-47	1 x 220-240	3.1 - 2.8	689	
CMB 3-56	1 x 220-240	4.4 - 4.0	869	
CMB 5-28	1 x 220-240	3.1 - 2.8	715	
CMB 5-47	1 x 220-240	5.4 - 5.0	1160	
CMB 5-38	1 x 220-240	4.4 - 4.0	869	AU

Approvals

The product is built according to European drinking water approvals.

Wetted parts

The table below specifies the parts of the pump that are in contact with the pumped liquid.

Designation	Material	Technical description
Pump sleeve	Stainless steel	EN 1.4301 AISI 304
Impeller	Stainless steel	EN 1.4301 AISI 304
Diffuser	Technopolymer	PP 20 % Talc
Ejector	Technopolymer	PPE/PS 20 % GF
Nozzle	Stainless steel	EN 1.4301 AISI 304
Shaft	Stainless steel	EN 1.4301 AISI 304
Shaft seal	Carbon with resin/ceramic	CVBP
Filling plug	Technopolymer	PES 30 % GF
Drain plug	Technopolymer	PES 30 % GF

Dimensional drawings

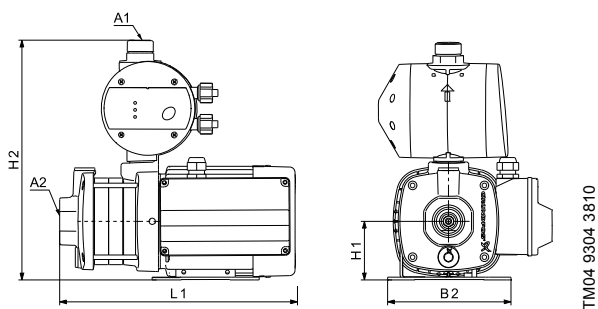

Pump	A1 [inch]	A2 [inch]	L1	B2	H1	H2
Cast Iron						
CMB 1-27	1	1	305	158	75	317
CMB 1-36	1	1	323	158	75	317
CMB 1-45	1	1	341	158	75	317
CMB 1-54	1	1	377	158	75	317
CMB 3-28	1	1	305	158	75	317
CMB 3-37	1	1	323	158	75	317
CMB 3-47	1	1	341	158	75	317
CMB 3-56	1	1	417	158	75	317
CMB 5-28	1	1 1/4	305	158	75	317
CMB 5-38	1	1 1/4	363.5	158	75	317
CMB 5-47	1	1 1/4	381	158	75	317
Stainless steel						
CMB 1-27	1	1	305	158	75	317
CMB 1-36	1	1	323	158	75	317
CMB 1-45	1	1	341	158	75	317
CMB 1-54	1	1	377	158	75	317
CMB 3-28	1	1	305	158	75	317
CMB 3-37	1	1	323	158	75	317
CMB 3-47	1	1	341	158	75	317
CMB 3-56	1	1	417	158	75	317
CMB 5-28	1	1 1/4	305	158	75	317
CMB 5-47	1	1 1/4	381	158	75	317

Performance curves

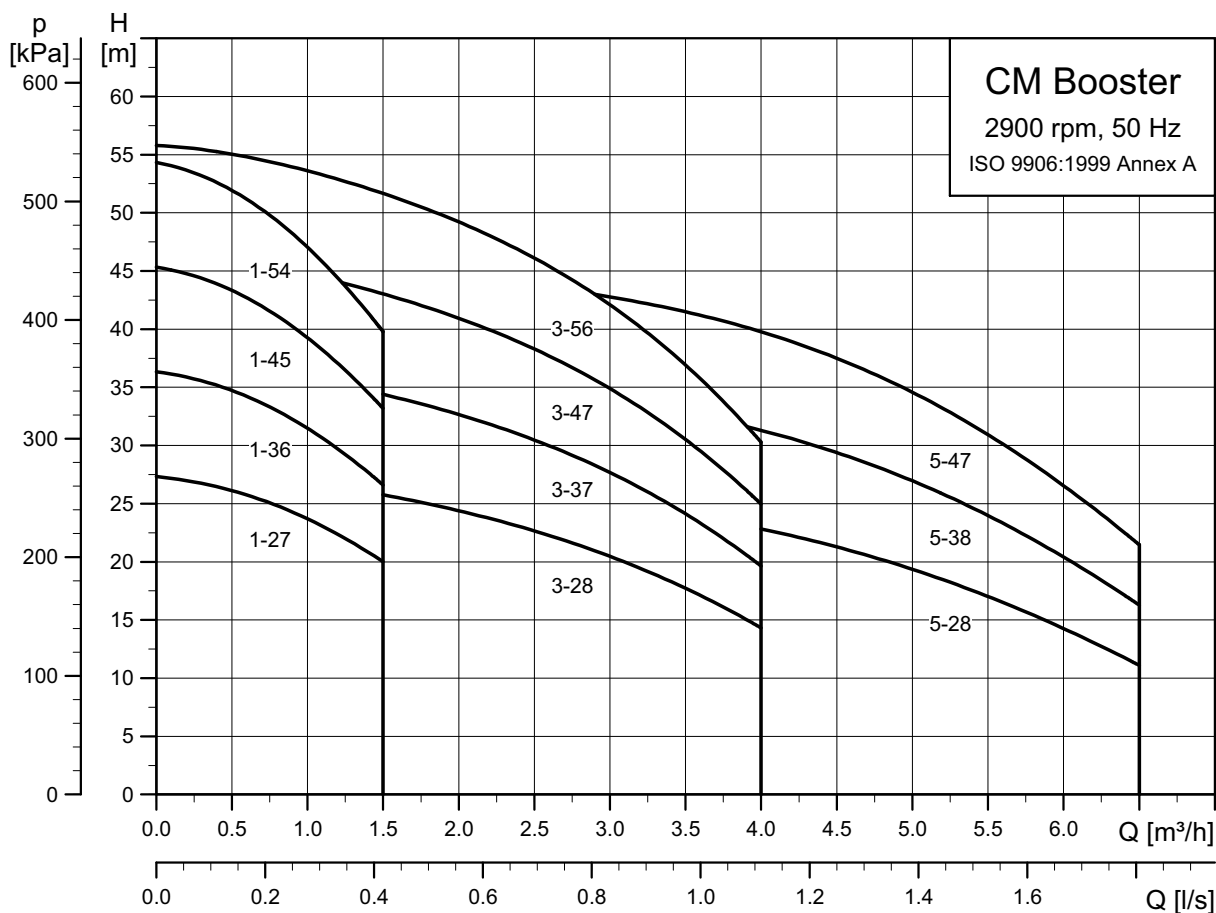

TM06 1282 1514

8. CMB PT

CM Booster pressure tank



TM05 9264 3713 - TM05 9265 3713

Fig. 15 CM Booster PT

The Grundfos CM Booster PT is an automatic booster system for water supply in domestic and agricultural applications as well as other installations where small leakages are expected to occur.

The booster system consists of a Grundfos CM pump, a pressure tank and a pressure switch assembled into one unit. The tank is delivered with the product and is easily connected to the CM pump.

The system is now ready for use, with preset start pressure and compliant tank precharge pressure. The pressure band is approximately 1 bar.

When the system has been connected to the pipes, it is all a matter of inserting the plug into a power supply socket, and the system is operational.

Applications

The Grundfos CM PT Booster is mainly used for agricultural and light commercial water supply and similar water installations where minor leakages can be expected.

Application	CMB 1	CMB 3	CMB 5
Agriculture	●	●	●
Irrigation	●	●	●
Single-family houses	○	○	○
Two-family houses	○	○	○
Cluster homes	○	○	○
Blocks of flats	○	○	○
Schools	○	○	○
Small hotels or guest houses	○	○	○
Small office buildings	○	○	○

- Recommended
- Applicable.

Motor

Single-phase CM pumps incorporate current- and temperature-dependent motor protection according to IEC 60034-11 and require no external motor protection.

Three-phase CM pumps do not incorporate motor protection. The CM pumps require external motor protection.

Features

- CM pump
- pressure tank to minimise the number of pump starts
- motor protection (single-phase only)
- automatic operation.

Operating conditions

System pressure	Max. 10 bar.
Suction lift	Max. 1 m, including suction-pipe pressure loss at a liquid temperature of +20 °C.
Liquid temperature	0-60 °C.
Ambient temperature	Max. +50 °C. Min. -20 °C.
Relative humidity	Max. 95 %.
Enclosure class	IP44.
Insulation class	F.
Sound pressure level	The sound pressure level of the pump is below 55 dB(A).
Supply voltage	1 x 220-240 V, 50 Hz. 3 x 220-240 / 380-415 V, 50 Hz.
Start/stop frequency	Max. 100 per hour.
Cut-in pressure	1.5 bar.

Electrical data

Vertical tank, 1 x 220-240 V, 50 Hz

Pump type	Voltage [V]	I _{max} [A]	P1 [W]	Plug type
CMB 1-36	1 x 220-240	3.1 - 2.8	436	AU
CMB 1-45	1 x 220-240	3.1 - 2.8	498	Schuko
CMB 3-37	1 x 220-240	3.1 - 2.8	587	AU
CMB 3-37	1 x 220-240	3.1 - 2.8	587	Schuko
CMB 3-47	1 x 220-240	3.1 - 2.8	690	Schuko
CMB 5-38	1 x 220-240	4.4 - 4.0	925	Schuko
CMB 5-47	1 x 220-240	5.4 - 5.0	1160	Schuko

All pumps are fitted with a 1.5 m cable.

Horizontal tank, 1 x 220-240 V, 50 Hz

Pump type	Voltage [V]	I _{max} [A]	P1 [W]	Plug type
CMB 3-37	1 x 220-240	3.1 - 2.8	587	Schuko
CMB 3-47	1 x 220-240	3.1 - 2.8	689	Schuko
CMB 3-56	1 x 220-240	4.4 - 4.0	869	Schuko
CMB 5-28	1 x 220-240	3.1 - 2.8	715	Schuko
CMB 5-37	1 x 220-240	4.4 - 4.0	869	Schuko
CMB 5-47	1 x 220-240	5.4 - 5.0	1160	Schuko

All pumps are fitted with a 1.5 m cable.

Horizontal tank, 3 x 230/400 V, 50 Hz

Pump type	Voltage [V]	I _{max} [A]	P1 [W]	Plug type
CMB 3-47	3 x 230/400	3.1 - 2.8	689	none
CMB 3-56	3 x 230/400	4.4 - 4.0	869	none
CMB 5-28	3 x 230/400	4.4 - 4.0	869	none
CMB 5-38	3 x 230/400	5.4 - 5.0	1160	none
CMB 5-47	3 x 230/400	5.4 - 5.0	1160	none

All pumps are fitted with a 1.5 m cable.

Approvals

The product is built according to European drinking water approvals.

Wetted parts

The table below specifies the parts of the pump that are in contact with the pumped liquid.

Designation	Material	Technical description
Pump sleeve	Stainless steel	EN 1.4301 AISI 304
Impeller	Stainless steel	EN 1.4301 AISI 304
Diffuser	Technopolymer	PP 20 % Talc
Ejector	Technopolymer	PPE/PS 20 % GF
Nozzle	Stainless steel	EN 1.4301 AISI 304
Shaft	Stainless steel	EN 1.4301 AISI 304
Shaft seal	Carbon with resin/ceramic	CVBP
Filling plug	Technopolymer	PES 30 % GF
Drain plug	Technopolymer	PES 30 % GF

Dimensional drawings

Vertical tank

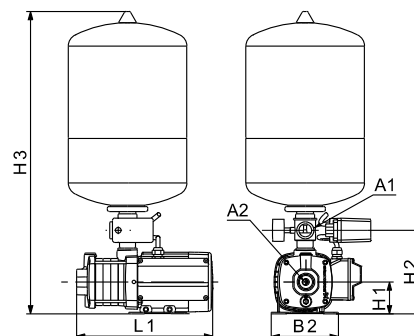

TM05 4150 2012

CMB	Tank [l]	H3	H1	H2	A1 [inch]	A2 [inch]	L1	B2
CMB 1-36	18	585	75	195	1	1	323.5	158
CMB 1-45	18	585	75	195	1	1	341.5	158
CMB 3-37	18	585	75	195	1	1	323.5	158
CMB 3-47	18	585	75	195	1	1	341.5	158
CMB 5-38	18	585	75	195	1	1 1/4	363.5	158
CMB 5-47	24	675	75	195	1	1 1/4	381.5	158

Horizontal tank

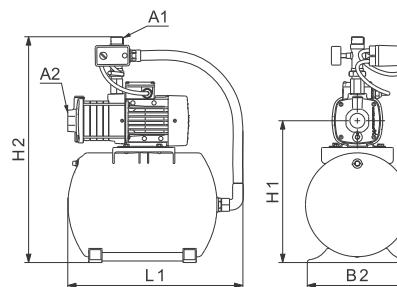

TM05 1606 3311

Pump type	Tank [l]	H1	H2	A1 [inch]	A2 [inch]	L1	B2
CMB 3-37	24	521	708	1	1	470	289
CMB 3-37	60	605	792	1	1 1/4	555	414
CMB 3-47	24	521	708	1	1	470	289
CMB 3-47	60	605	792	1	1 1/4	555	414
CMB 3-54	24	521	708	1	1	470	289
CMB 3-54	60	605	792	1	1 1/4	555	414
CMB 5-28	60	605	792	1	1 1/4	555	414
CMB 5-38	24	521	708	1	1	470	289
CMB 5-38	60	605	792	1	1 1/4	555	414
CMB 5-47	24	521	708	1	1	470	289
CMB 5-47	60	605	792	1	1 1/4	555	414

Performance curves

Vertical tank

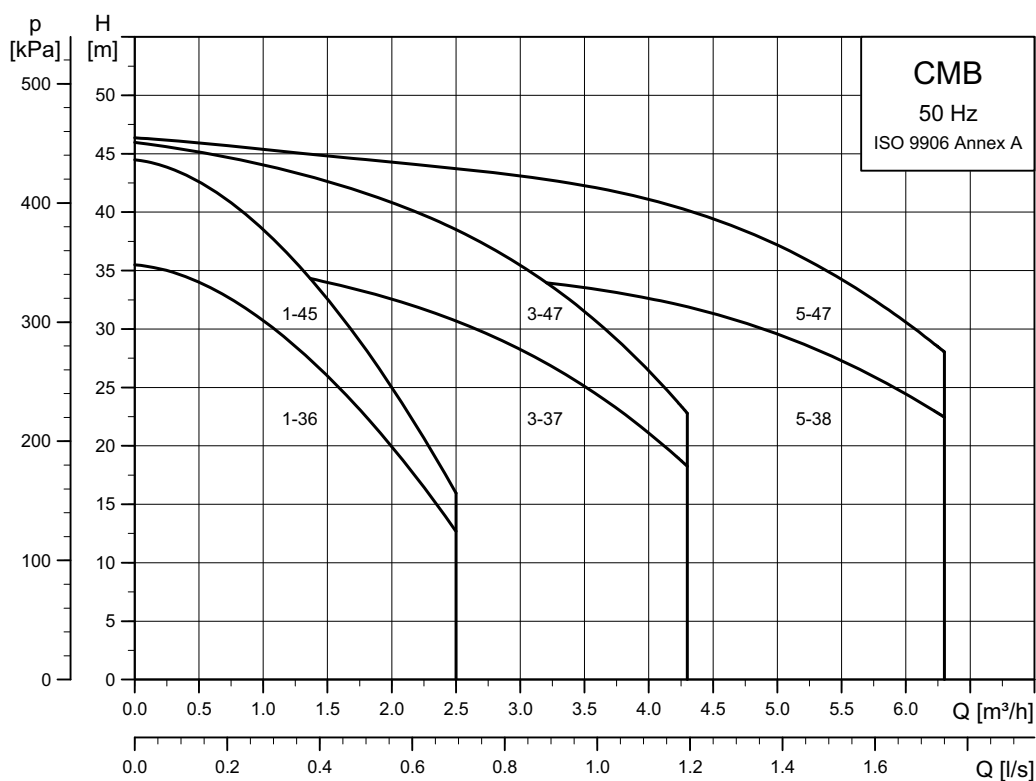

Pressure losses in fittings and hose are not included.

Horizontal tank

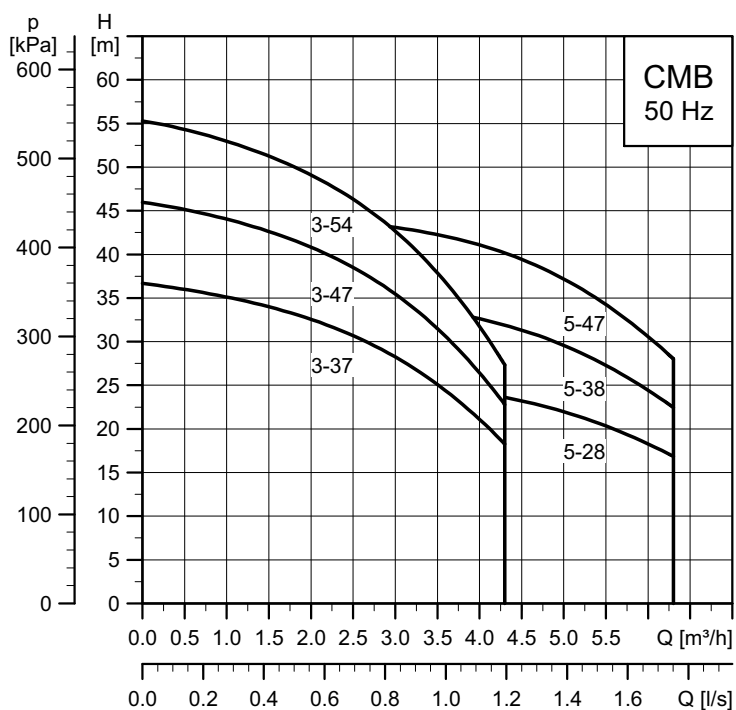

Pressure losses in fittings and hose are not included.

TM05 4260 2212

TM06 28 34 4614

9. CMB PS

CM Booster with pressure switch



TMO5 5049 3212

Fig. 16 CM Booster PS

The Grundfos CM PS Booster PS is an automatic booster for water supply in domestic and agricultural applications as well as other installations where small leakages are expected to occur.

The booster system consists of a Grundfos CM pump, a 5-way valve and a pressure switch. A pressure tank must be fitted to complete the booster system. Use your own pressure tank or order one of the Grundfos GT tanks that make a perfect fit for your booster system.

The pressure band is approximately 1 bar.

When the system has been connected to the pipes, it is all a matter of inserting the plug into a power supply socket, and the system is operational.

Applications

The Grundfos CM PS Booster is mainly used for agricultural and light commercial water supply and similar water installations where minor leakages can be expected.

Motor

Application	CMB 1	CMB 3	CMB 5	CMB 10
Agriculture	•	•	•	•
Irrigation	•	•	•	•
Single-family houses	○	○	○	○
Two-family houses	○	○	○	○
Cluster homes	○	○	○	○
Blocks of flats	○	○	○	○
Schools	○	○	○	○
Small hotels or guest houses	○	○	○	○
Small office buildings	○	○	○	○

- Recommended
- Applicable.

Single-phase motors

Single-phase CM pumps incorporate current- and temperature-dependent motor protection according to IEC 60034-11 and require no external motor protection.

Three-phase motors

Three-phase CM pumps do not incorporate motor protection and therefore require external motor protection.

Features

- CM pump
- pressure tank to minimise the number of pump starts
- motor protection (single-phase only)
- automatic operation.

Operating conditions

System pressure	Max. 10 bar.
Suction lift	Max. 1 m, including suction-pipe pressure loss at a liquid temperature of +20 °C.
Liquid temperature	0-60 °C.
Ambient temperature	Max. +55 °C. Min. -20 °C.
Relative humidity	Max. 95 %.
Enclosure class	IP44.
Insulation class	F.
Sound pressure level	The sound pressure level of the pump is below 62 dB(A).
Supply voltage	1 x 220-240 V, 50 Hz. 3 x 220-240 / 380-415 V, 50 Hz.
Start/stop frequency	Max. 100 per hour.
Cut-in pressure	1.5 bar.

Electrical data

1 x 220-240 V, 50 Hz

Pump type	Voltage [V]	I_{max} [A]	P1 [W]	Plug type
CMB 1-36	1 x 220-240 V	3.1 - 2.8	436	AU
CMB 3-37	1 x 220-240 V	3.1 - 2.8	587	AU
CMB 5-47	1 x 220-240 V	5.4 - 5.0	1410	AU
CMB 5-55	1 x 220-240 V	8.4 - 8.0	1410	AU
CMB 5-74	1 x 220-240 V	8.4 - 8.0	1790	AU
CMB 5-93	1 x 220-240 V	11.0 - 10.0	2130	AU
CMB 10-46	1 x 220-240 V	11.0 - 10.0	2070	AU

All pumps are fitted a with 1.5 m cable.

3 x 230/400 V, 50 Hz

Pump type	Voltage [V]	I_{max} [A]	P1 [W]	Plug type
CMB 5-47	3 x 230/400 V	4.8 - 5.2 / 2.8 - 3	1170	AU
CMB 5-55	3 x 230/400 V	4.8 - 5.2 / 2.8 - 3	1360	AU
CMB 5-74	3 x 230/400 V	5.55 - 5.38 / 3.25 - 3	1840	AU
CMB 5-93	3 x 230/400 V	8.05 - 7.5 / 4.7 - 4.35	2320	AU
CMB 10-46	3 x 230/400 V	8.05 - 7.5 / 4.7 - 4.35	2250	AU
CMB 10-62	3 x 230/400 V	11.8 - 11.0 / 6.75 - 6.40	3000	AU
CMB 10-77	3 x 230/400 V	11.8 - 11.0 / 6.75 - 6.40	3710	AU
CMB 10-93	3 x 230/400 V	14.0 - 13.2 / 8.20 - 7.80	4600	AU

All pumps come without cable.

Approvals

The product is built according to European drinking water approvals.

Wetted parts

The table below specifies the parts of the pump that are in contact with the pumped liquid.

Designation	Material	Technical description
Pump sleeve	Stainless steel	EN 1.4301 AISI 304
Impeller	Stainless steel	EN 1.4301 AISI 304
Diffuser	Technopolymer	PP 20 % Talc
Ejector	Technopolymer	PPE/PS 20 % GF
Nozzle	Stainless steel	EN 1.4301 AISI 304
Shaft	Stainless steel	EN 1.4301 AISI 304
Shaft seal	Carbon with resin/ceramic	CVBP
Filling plug	Technopolymer	PES 30 % GF
Drain plug	Technopolymer	PES 30 % GF

Dimensional drawings

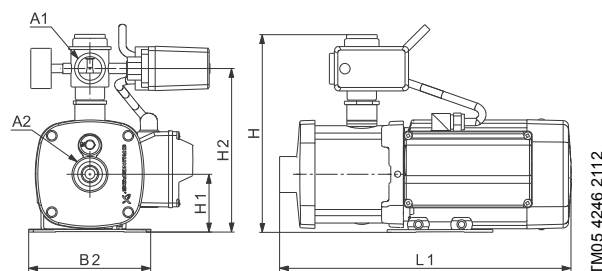

1 x 220-240 V, 50 Hz

Pump type	H	H1	H2	A1 [inch]	A2 [inch]	L1	B2
CMB 1-36	255	75.0	208	1	1	323.0	158.0
CMB 3-37	255	75.0	208	1	1	323.0	158.0
CMB 5-47	255	75.0	208	1	1 1/4	381.0	158.0
CMB 5-55	270	90.0	223	1	1 1/4	466.5	178.0
CMB 5-74	270	90.0	223	1	1 1/4	502.5	178.0
CMB 5-93	270	90.0	223	1	1 1/4	538.5	178.0
CMB 10-46	323	100.0	261	1 1/2	1 1/4	450.0	199.0

3 x 230/400 V, 50 Hz

Pump type	H	H1	H2	A1 [inch]	A2 [inch]	L1	B2
CMB 5-47	255	75.0	208	1	1 1/4	401.0	158.0
CMB 5-55	255	75.0	208	1	1 1/4	437.0	158.0
CMB 5-74	270	90.0	223	1	1 1/4	502.5	178.0
CMB 5-93	270	90.0	223	1	1 1/4	578.5	178.0
CMB 10-46	323	100.0	261	1 1/2	1 1/2	490.0	199.0
CMB 10-62	323	100.0	261	1 1/2	1 1/2	537.0	199.0
CMB 10-77	323	100.0	261	1 1/2	1 1/2	597.0	199.0
CMB 10-93	323	100.0	261	1 1/2	1 1/2	597.0	199.0

Performance range

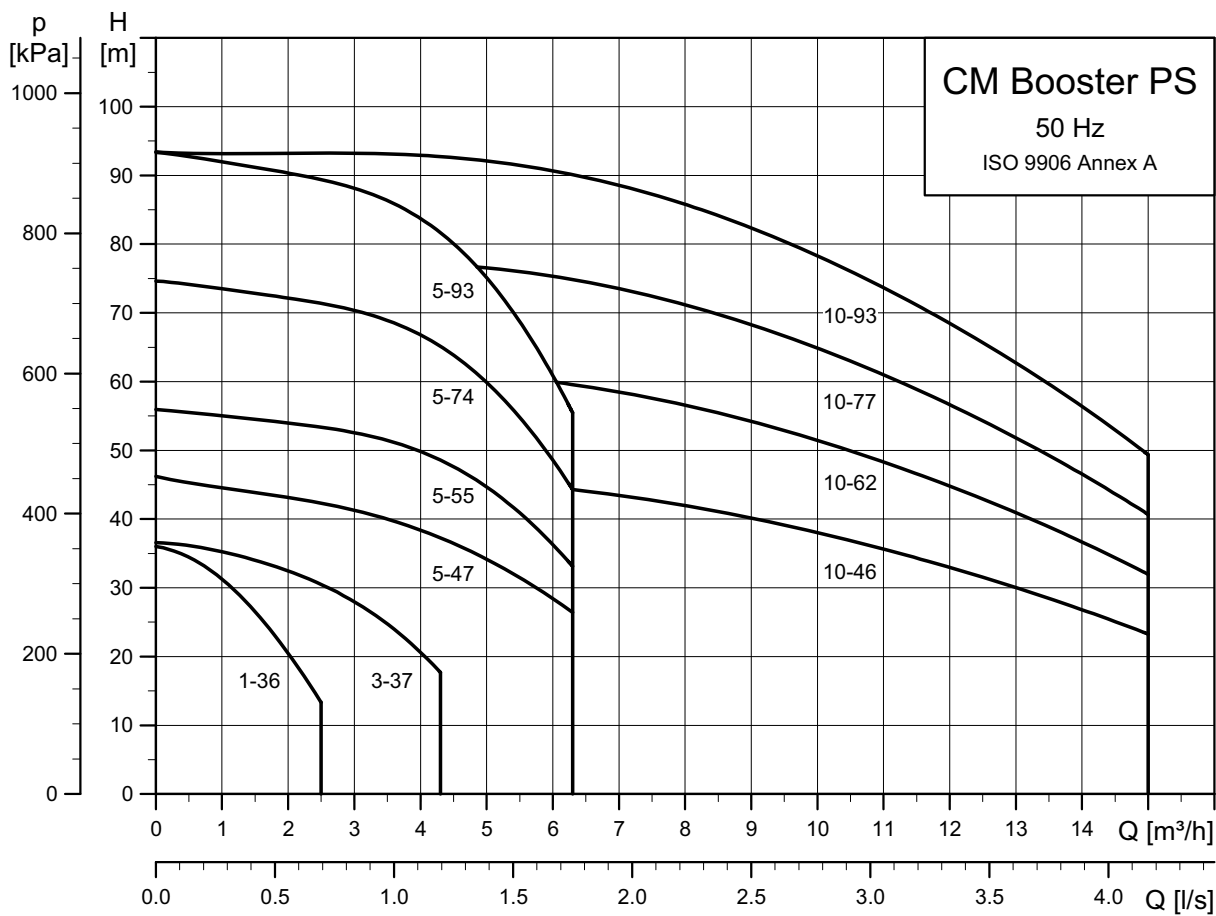

Pressure losses in fittings and hose are not included.

TM05 4765 2612

10. Product numbers

CMBE TWIN

D: Integrated frequency converter.

Pump type	Controller	Stainless steel	Cast iron	Self-priming	Inlet pressure switch	Plug	Product number
CMBE 3, 1 x 200-240 V, 50/60 Hz							
CMBE 3-30	D	•				Schuko	99219419
CMBE 3-30	D	•				Fuse Box	99220843
CMBE 3-62	D	•				Schuko	99219420
CMBE 3-62	D	•				Fuse Box	99220844
CMBE 3-93	D	•				Schuko	99219421
CMBE 3-93	D	•				Fuse Box	99220845
CMBE 5, 1 x 200-240 V, 50/60 Hz							
CMBE 5-31	D	•				Schuko	99219422
CMBE 5-31	D	•				Fuse Box	99220846
CMBE 5-62	D	•				Schuko	99219423
CMBE 5-62	D	•				Fuse Box	99220847
CMBE TWIN Accessories							
Accessory type	Ball valve	Unions	1 1/2" outlet connection	1" inlet connection	1/4" inlet connection		Product Number
Vibration damper kit							99217259
Inlet/outlet pipe kit	•	•	•	•			99229422
Inlet/outlet pipe kit	•	•	•		•		99229453

CMBE

D: Integrated frequency converter.

Pump type	Controller	Stainless steel	Cast iron	Self-priming	Inlet pressure switch	Plug	Product number
CMBE 1, 1 x 200-240 V, 50/60 Hz							
CMBE 1-44	D	•				US	98374721
CMBE 1-44	D	•				Schuko	98374697
CMBE 1-44	D	•				none	98374679
CMBE 1-44	D	•				AU	98374705
CMBE 1-44	D	•				UK	98374713
CMBE 1-44	D	•			•	Schuko	98563698
CMBE 1-75	D	•				US	98374722
CMBE 1-75	D	•				Schuko	98374698
CMBE 1-75	D	•				none	98374680
CMBE 1-75	D	•				AU	98374706
CMBE 1-75	D	•				UK	98374714
CMBE 1-75	D	•			•	Schuko	98563702
CMBE 1-99	D	•				US	98374723
CMBE 1-99	D	•				Schuko	98374699
CMBE 1-99	D	•				none	98374691
CMBE 1-99	D	•				AU	98374707
CMBE 1-99	D	•				UK	98374715
CMBE 1-99	D	•			•	Schuko	98563704
CMBE 3, 1 x 200-240 V, 50/60 Hz							
CMBE 3-30	D	•				US	98374724
CMBE 3-30	D	•				Schuko	98374700
CMBE 3-30	D	•				none	98374692
CMBE 3-30	D	•				AU	98374708
CMBE 3-30	D	•				UK	98374716
CMBE 3-30	D	•			•	Schuko	98563707
CMBE 3-62	D	•				US	98374725
CMBE 3-62	D	•				Schuko	98374701
CMBE 3-62	D	•				none	98374693
CMBE 3-62	D	•				AU	98374709
CMBE 3-62	D	•				UK	98374717
CMBE 3-62	D	•			•	Schuko	98563709
CMBE 3-93	D	•				US	98374726
CMBE 3-93	D	•				Schuko	98374702
CMBE 3-93	D	•				none	98374694
CMBE 3-93	D	•				AU	98374710
CMBE 3-93	D	•				UK	98374718
CMBE 3-93	D	•			•	Schuko	98563722

Pump type	Controller	Stainless steel	Cast iron	Self-priming	Inlet pressure switch	Plug	Product number
CMBE 5, 1 x 200-240 V, 50/60 Hz							
CMBE 5-31	D	•				US	98374727
CMBE 5-31	D	•				Schuko	98374703
CMBE 5-31	D	•				none	98374695
CMBE 5-31	D	•				AU	98374711
CMBE 5-31	D	•				UK	98374719
CMBE 5-31	D	•			•	Schuko	98563725
CMBE 5-62	D	•				US	98374728
CMBE 5-62	D	•				Schuko	98374704
CMBE 5-62	D	•				none	98374696
CMBE 5-62	D	•				AU	98374712
CMBE 5-62	D	•				UK	98374720
CMBE 5-62	D	•			•	Schuko	98563727
CMBE 10, 1 x 200-240 V, 50/60 Hz							
CMBE 10-54	D	•				US	98382208
CMBE 10-54	D	•				Schuko	98382202
CMBE 10-54	D	•				none	98382190
CMBE 10-54	D	•				AU	98382204
CMBE 10-54	D	•				UK	98382206
CMBE 10-54	D	•			•	Schuko	98563731

CMB PM 1

Pump type	Controller	Stainless steel	Cast iron	Self-priming	Set	Plug	Product number
CMB 1 PM 1, 1 x 220 V, 50 Hz							
CMB 1-27	PM 1-15		•			US	97530089
CMB 1-27	PM 1-15		•			Schuko	97530087
CMB 1-27	PM 1-15		•			none	97530090
CMB 1-27	PM 1-15		•			AU	97530088
CMB 1-27	PM 1-15	•				US	97530093
CMB 1-27	PM 1-15	•				Schuko	97530091
CMB 1-27	PM 1-15	•				none	97530094
CMB 1-27	PM 1-15	•				AU	97530092
CMB-SP 1-27	PM 1-15	•		•		Schuko	98507555
CMB-SP 1-27	PM 1-15	•		•		none	98507558
CMB-SP 1-27	PM 1-15	•		•		AU	98507561
CMB 1-36	PM 1-15		•			US	97530098
CMB 1-36	PM 1-15		•			Schuko	97530096
CMB 1-36	PM 1-15		•			none	97530099
CMB 1-36	PM 1-15		•			AU	97530097
CMB 1-36	PM 1-15	•				US	97530102
CMB 1-36	PM 1-15	•				Schuko	97530100
CMB 1-36	PM 1-15	•				none	97530103
CMB 1-36	PM 1-15	•				AU	97530101
CMB-SP 1-36	PM 1-15	•		•		Schuko	98507556
CMB-SP 1-36	PM 1-15	•		•		none	98507559
CMB-SP 1-36	PM 1-15	•		•		AU	98507562
CMB 1-45	PM 1-15		•			US	97530107
CMB 1-45	PM 1-15		•			Schuko	97530105
CMB 1-45	PM 1-15		•			none	97530108
CMB 1-45	PM 1-15		•			AU	97530106
CMB 1-45	PM 1-15	•				US	97530111
CMB 1-45	PM 1-15	•				Schuko	97530109
CMB 1-45	PM 1-15	•				none	97530112
CMB 1-45	PM 1-15	•				AU	97530110
CMB-SP 1-45	PM 1-15	•		•		Schuko	98507557
CMB-SP 1-45	PM 1-15	•		•		none	98507560
CMB-SP 1-45	PM 1-15	•		•		AU	98507563
CMB 1-54	PM 1-22		•			US	97530116
CMB 1-54	PM 1-22		•			Schuko	97530114
CMB 1-54	PM 1-22		•			none	97530117
CMB 1-54	PM 1-22		•			AU	97530115
CMB 1-54	PM 1-22	•				US	97530120
CMB 1-54	PM 1-22	•				Schuko	97530118
CMB 1-54	PM 1-22	•				none	97530121
CMB 1-54	PM 1-22	•				AU	97530119
CMB-SP 1-54	PM 1-22	•		•		Schuko	98507570
CMB-SP 1-54	PM 1-22	•		•		none	98507571
CMB-SP 1-54	PM 1-22	•		•		AU	98507572
CMB 3 PM 1, 220 V, 50 Hz							
CMB 3-27	PM 1-15		•			US	97530125
CMB 3-27	PM 1-15		•			Schuko	97530123
CMB 3-27	PM 1-15		•			none	97530126
CMB 3-27	PM 1-22		•			none	97687665
CMB 3-27	PM 1-15		•			AU	97530124
CMB 3-27	PM 1-15	•				US	97530129
CMB 3-27	PM 1-15	•				Schuko	97530127
CMB 3-27	PM 1-15	•				none	97530130
CMB 3-27	PM 1-22	•				none	97687666
CMB 3-27	PM 1-15	•				AU	97530128
CMB-SP 3-28	PM 1-15	•		•		AU	98507568
CMB-SP 3-28	PM 1-15	•		•		none	98507566
CMB-SP 3-28	PM 1-15	•		•	•	Schuko	98507586
CMB-SP 3-28	PM 1-15	•		•		Schuko	98507564
CMB 3-37	PM 1-15		•			US	97530134
CMB 3-37	PM 1-15		•			Schuko	97530132
CMB 3-37	PM 1-22		•			none	97687667
CMB 3-37	PM 1-15		•			none	97530135
CMB 3-37	PM 1-15		•			AU	97530133
CMB 3-37	PM 1-15	•				US	97530138
CMB 3-37	PM 1-15	•				Schuko	97530136

Pump type	Controller	Stainless steel	Cast iron	Self-priming	Set	Plug	Product number
CMB 3-37	PM 1-15	•				none	97530139
CMB 3-37	PM 1-15	•				AU	97530137
CMB 3-37	PM 1-22	•				none	97687668
CMB-SP 3-37	PM 1-15	•		•		AU	98507569
CMB-SP 3-37	PM 1-15	•		•		none	98507567
CMB-SP 3-37	PM 1-15	•		•	•	Schuko	98507587
CMB-SP 3-37	PM 1-15	•		•		Schuko	98507565
CMB 3-46	PM 1-22		•			US	97530143
CMB 3-46	PM 1-22		•			Schuko	97530141
CMB 3-46	PM 1-22		•			none	97530144
CMB 3-46	PM 1-22		•			AU	97530142
CMB 3-46	PM 1-22	•				US	97530147
CMB 3-46	PM 1-22	•				Schuko	97530145
CMB 3-46	PM 1-22	•				none	97530148
CMB 3-46	PM 1-22	•				AU	97530146
CMB-SP 3-47	PM 1-22	•		•		AU	98507577
CMB-SP 3-47	PM 1-22	•		•		none	98507575
CMB-SP 3-47	PM 1-22	•		•	•	Schuko	98507588
CMB-SP 3-47	PM 1-22	•		•		Schuko	98507573
CMB 3-55	PM 1-22		•			US	97530152
CMB 3-55	PM 1-22		•			Schuko	97530150
CMB 3-55	PM 1-22		•			none	97530153
CMB 3-55	PM 1-22		•			AU	97530151
CMB 3-55	PM 1-22	•				US	97530156
CMB 3-55	PM 1-22	•				Schuko	97530154
CMB 3-55	PM 1-22	•				AU	97530155
CMB 3-55	PM 1-22	•				none	97530157
CMB-SP 3-56	PM 1-22	•		•		AU	98507578
CMB-SP 3-56	PM 1-22	•		•		none	98507576
CMB-SP 3-56	PM 1-22	•		•	•	Schuko	98507589
CMB-SP 3-56	PM 1-22	•		•		Schuko	98507574
CMB 5 PM 1, 220 V, 50 Hz							
CMB 5-28	PM 1-22		•			US	97530161
CMB 5-28	PM 1-22		•			Schuko	97530159
CMB 5-28	PM 1-22		•			none	97530162
CMB 5-28	PM 1-15		•			none	97687683
CMB 5-28	PM 1-22		•			AU	97530160
CMB 5-28	PM 1-15		•			AU	97687670
CMB 5-28	PM 1-22	•				US	97530165
CMB 5-28	PM 1-22	•				Schuko	97530163
CMB 5-28	PM 1-22	•				none	97530166
CMB 5-28	PM 1-15	•				none	97687684
CMB 5-28	PM 1-22	•				AU	97530164
CMB 5-28	PM 1-15	•				AU	97687682
CMB-SP 5-28	PM 1-22	•		•		Schuko	98507579
CMB-SP 5-28	PM 1-22	•		•		none	98507582
CMB-SP 5-28	PM 1-22	•		•		AU	98507584
CMB 5-37	PM 1-22		•			AU	97687685
CMB 5-46	PM 1-22		•			US	97530170
CMB 5-46	PM 1-22		•			Schuko	97530168
CMB 5-46	PM 1-22		•			none	97530171
CMB 5-46	PM 1-22		•			AU	97530169
CMB 5-47	PM 1-22	•				US	97530174
CMB 5-47	PM 1-22	•				Schuko	97530172
CMB 5-47	PM 1-22	•				none	97530175
CMB 5-47	PM 1-22	•				AU	97530173
CMB-SP 5-47	PM 1-22	•		•		Schuko	98507581
CMB-SP 5-47	PM 1-22	•		•		none	98507583
CMB-SP 5-47	PM 1-22	•		•		AU	98507585

CMB PM 2

Pump type	Controller	Stainless steel	Cast iron	Self-priming	Set	Plug	Product number
CMB 1 PM 2, 220 V, 50 Hz							
CMB 1-27	PM 2	•				US	97529989
CMB 1-27	PM 2	•				Schuko	97529987
CMB 1-27	PM 2	•				none	97529990
CMB 1-27	PM 2	•				AU	97529988
CMB 1-27	PM 2		•			US	97530003
CMB 1-27	PM 2		•			Schuko	97530001
CMB 1-27	PM 2		•			none	97530004
CMB 1-27	PM 2		•			AU	97530002
CMB-SP 1-27	PM 2	•		•		Schuko	98507607
CMB-SP 1-27	PM 2	•		•		none	98507611
CMB-SP 1-27	PM 2	•		•		AU	98507615
CMB 1-36	PM 2	•				US	97530008
CMB 1-36	PM 2	•				Schuko	97530006
CMB 1-36	PM 2	•				none	97530009
CMB 1-36	PM 2	•				AU	97530007
CMB 1-36	PM 2		•			US	97530012
CMB 1-36	PM 2		•			Schuko	97530010
CMB 1-36	PM 2		•			none	97530013
CMB 1-36	PM 2		•			AU	97530011
CMB-SP 1-36	PM 2	•		•		Schuko	98507608
CMB-SP 1-36	PM 2	•		•		none	98507612
CMB-SP 1-36	PM 2	•		•		AU	98507616
CMB 1-45	PM 2		•			US	97530021
CMB 1-45	PM 2		•			Schuko	97530019
CMB 1-45	PM 2		•			none	97530022
CMB 1-45	PM 2		•			AU	97530020
CMB 1-45	PM 2	•				US	97530017
CMB 1-45	PM 2	•				Schuko	97530015
CMB 1-45	PM 2	•				none	97530018
CMB 1-45	PM 2	•				AU	97530016
CMB-SP 1-45	PM 2	•		•		Schuko	98507609
CMB-SP 1-45	PM 2	•		•		none	98507613
CMB-SP 1-45	PM 2	•		•		AU	98507617
CMB 1-54	PM 2		•			US	97530030
CMB 1-54	PM 2		•			Schuko	97530028
CMB 1-54	PM 2		•			none	97530031
CMB 1-54	PM 2		•			AU	97530029
CMB 1-54	PM 2	•				US	97530026
CMB 1-54	PM 2	•				Schuko	97530024
CMB 1-54	PM 2	•				none	97530027
CMB 1-54	PM 2	•				AU	97530025
CMB-SP 1-54	PM 2	•		•		Schuko	98507610
CMB-SP 1-54	PM 2	•		•		none	98507614
CMB-SP 1-54	PM 2	•		•		AU	98507618
CMB 3 PM 2, 220 V, 50 Hz							
CMB 3-27	PM 2		•			US	97530039
CMB 3-27	PM 2		•			Schuko	97530037
CMB 3-27	PM 2		•			none	97530040
CMB 3-27	PM 2		•			AU	97530038
CMB 3-27	PM 2	•				US	97530035
CMB 3-27	PM 2	•				Schuko	97530033
CMB 3-27	PM 2	•				none	97530036
CMB 3-27	PM 2	•				AU	97530034
CMB-SP 3-28	PM 2	•		•	•	Schuko	98507637
CMB-SP 3-28	PM 2	•		•		Schuko	98507619
CMB-SP 3-28	PM 2	•		•		none	98507623
CMB-SP 3-28	PM 2	•		•		AU	98507627
CMB 3-37	PM 2		•			US	97530048
CMB 3-37	PM 2		•			Schuko	97530046
CMB 3-37	PM 2		•			none	97530049
CMB 3-37	PM 2		•			AU	97530047
CMB 3-37	PM 2	•				US	97530044
CMB 3-37	PM 2	•				Schuko	97530042
CMB 3-37	PM 2	•				none	97530045
CMB 3-37	PM 2	•				AU	97530043
CMB-SP 3-37	PM 2	•		•	•	Schuko	98507638

Pump type	Controller	Stainless steel	Cast iron	Self-priming	Set	Plug	Product number
CMB-SP 3-37	PM 2	•		•		Schuko	98507620
CMB-SP 3-37	PM 2	•		•		none	98507624
CMB-SP 3-37	PM 2	•		•		AU	98507628
CMB 3-46	PM 2		•			US	97530057
CMB 3-46	PM 2		•			Schuko	97530055
CMB 3-46	PM 2		•			none	97530058
CMB 3-46	PM 2		•			AU	97530056
CMB 3-46	PM 2	•				US	97530053
CMB 3-46	PM 2	•				Schuko	97530051
CMB 3-46	PM 2	•				none	97530054
CMB 3-46	PM 2	•				AU	97530052
CMB-SP 3-47	PM 2	•		•	•	Schuko	98507639
CMB-SP 3-47	PM 2	•		•		Schuko	98507621
CMB-SP 3-47	PM 2	•		•		none	98507625
CMB-SP 3-47	PM 2	•		•		AU	98507629
CMB 3-55	PM 2		•			US	97530066
CMB 3-55	PM 2		•			Schuko	97530064
CMB 3-55	PM 2		•			none	97530067
CMB 3-55	PM 2		•			AU	97530065
CMB 3-55	PM 2	•				US	97530062
CMB 3-55	PM 2	•				Schuko	97530060
CMB 3-55	PM 2	•				none	97530063
CMB 3-55	PM 2	•				AU	97530061
CMB-SP 3-56	PM 2	•		•	•	Schuko	98507640
CMB-SP 3-56	PM 2	•		•		Schuko	98507622
CMB-SP 3-56	PM 2	•		•		none	98507626
CMB-SP 3-56	PM 2	•		•		AU	98507630
CMB-SP 3-56	PM 2	•		•		Schuko	98507640
CMB 5 PM 2, 220 V, 50 Hz							
CMB 5-28	PM 2		•			US	97530075
CMB 5-28	PM 2		•			Schuko	97530073
CMB 5-28	PM 2		•			none	97530076
CMB 5-28	PM 2		•			AU	97530074
CMB 5-28	PM 2	•				US	97530071
CMB 5-28	PM 2	•				Schuko	97530069
CMB 5-28	PM 2	•				none	97530072
CMB 5-28	PM 2	•				AU	97530070
CMB-SP 5-28	PM 2	•		•		Schuko	98507631
CMB-SP 5-28	PM 2	•		•		none	98507633
CMB-SP 5-28	PM 2	•		•		AU	98507635
CMB-SP 5-37	PM 2	•		•		AU	98576430
CMB 5-37	PM 2		•			AU	97687688
CMB 5-37	PM 2	•				AU	97687689
CMB 5-46	PM 2		•			US	97530084
CMB 5-46	PM 2		•			Schuko	97530082
CMB 5-46	PM 2		•			none	97530085
CMB 5-46	PM 2		•			AU	97530083
CMB 5-47	PM 2	•				US	97530080
CMB 5-47	PM 2	•				Schuko	97530078
CMB 5-47	PM 2	•				none	97530081
CMB 5-47	PM 2	•				AU	97530079
CMB-SP 5-47	PM 2	•		•		Schuko	98507632
CMB-SP 5-47	PM 2	•		•		none	98507634
CMB-SP 5-47	PM 2	•		•		AU	98507636

CMB PT and CMB PS

Pump type	Stainless steel	Cast iron	1-phase	3-phase	Tank size [l]	Plug	Product number
CMB 1 PT and CMB 1 PS							
CMB 1-36	•		•		-	AU	98244555
CMB 1-36		•	•		18, vertical	AU	98149669
CMB 1-45		•	•		18, vertical	Schuko	98189064
CMB 3 PT and CMB 3 PS							
CMB 3-37		•	•		18, vertical	AU	98149670
CMB 3-37		•	•		18, vertical	Schuko	98158257
CMB 3-37	•		•		-	AU	98244556
CMB 3-37		•	•		24, horizontal	Schuko	97766989
CMB 3-37		•	•		60, horizontal	Schuko	97767000
CMB 3-46		•		•	24, horizontal	none	97766996
CMB 3-46		•	•		18, vertical	Schuko	98158258
CMB 3-46		•	•		24, horizontal	Schuko	97766978
CMB 3-46		•	•		60, horizontal	Schuko	97766985
CMB 3-55		•	•		24, horizontal	Schuko	97766981
CMB 3-55		•		•	24, horizontal	none	97767001
CMB 3-55		•	•		60, horizontal	Schuko	97766992
CMB 3-74	•		•		24, horizontal	Schuko	98545520
CMB 5 PT and CMB 5 PS							
CMB 5-28		•	•		60, horizontal	Schuko	97766999
CMB 5-37		•	•		24, horizontal	Schuko	97766986
CMB 5-37		•		•	24, horizontal	none	97766997
CMB 5-37		•	•		18, vertical	Schuko	98158260
CMB 5-37		•	•		60, horizontal	Schuko	97766990
CMB 5-47	•			•	-	AU	98117636
CMB 5-46		•	•		24, vertical	Schuko	98158281
CMB 5-46		•		•	24, horizontal	none	97766987
CMB 5-46		•		•	60, horizontal	none	97766994
CMB 5-47	•		•		-	AU	98117630
CMB 5-46		•	•		24, horizontal	Schuko	97766979
CMB 5-46		•	•		60, horizontal	Schuko	97766980
CMB 5-56	•		•		-	AU	98117632
CMB 5-56	•			•	-	AU	98117637
CMB 5-75	•		•		-	AU	98117633
CMB 5-75	•			•	-	AU	98117638
CMB 5-93	•		•		-	AU	98117634
CMB 5-93	•			•	-	AU	98117639
CMB 10 PS							
CMB 10-47	•		•		-	AU	98117635
CMB 10-47	•			•	-	AU	98117640
CMB 10-62	•			•	-	AU	98117641
CMB 10-78	•			•	-	AU	98117642
CMB 10-93	•			•	-	AU	98117643

Accessories

The vital components from the booster solutions are also available as stand-alone products. They can be combined with any pump to create a booster system.

Grundfos Pressure Manager

Grundfos PM 1 and PM 2 pressure managers are designed for automatic start/stop control of Grundfos pumps and other water supply pumps.

PM 1

The PM 1 is suitable for applications where start/stop of the pump according to consumption is needed. It is the basic control solution offering start at 1.5 or 2.2 bar.

The PM 1 starts the pump when the start pressure is reached, and the pump keeps running as long as there is flow.

The PM 1 offers dry-running protection and cycling alarm for increased safety.



Fig. 17 PM 1

TM05 9266 3713

PM 2

The PM 2 is the all-round control solution offering adjustable start at 1.5 to 5 bar. This enables customisation to different types of installations and ensures a high level of comfort.

The start pressure is set by means of DIP switches located behind the control panel whereas the current pressure is indicated on the LED display on the front of the PM 2.

The PM 2 starts the pump when the start pressure is reached, and the pump keeps running as long as there is flow.

The PM 2 can be optimised for operation with an external pressure tank by enabling the 1 bar differential-pressure function. This function significantly reduces the number of operating hours of the pump in installations with a pressure tank.



Fig. 18 PM 2

TM05 9267 3713

Note: For further information, see the data booklet for Grundfos Pressure Manager.

Grundfos pressure tanks

Grundfos GT pressure tanks are long-life tanks, which are ideally suited for controlling the pressure in domestic as well as industrial applications.

GT-U, bladder

The pressure tank body is made of steel and is precharged with nitrogen from factory. All parts in contact with water are either made of stainless steel or coated for protection against corrosion. The replaceable bladder for tanks with a volume exceeding 60 litres is made of high-quality rubber material suitable for potable-water applications, such as booster systems, pressurisation and water hammer arresting.



Fig. 19 GT-U bladder tank

GT-H, diaphragm

The polypropylene liner combined with an FDA-approved high-grade butyl diaphragm makes up the water chamber. This is held against the tank wall with a steel clench ring. The brass air valve, sealed by a threaded O-ring valve cap, prevents air leaks.



Fig. 20 GT-H diaphragm tanks

Note: For further information, see the data booklet for Grundfos pressure tanks.

Inlet/outlet pipe kits for CMBE TWIN

Inlet and outlet pipe kits are available for the CMBE TWIN booster. All pipe kits include ball valve and unions and 1 1/2" outlet connection. The inlet connection is available in two sizes.

Type	Product Numbers
1" inlet connection	PN 99229422
1/4" inlet connection	PN 99229453

Vibration damper kit for CMBE TWIN

The vibration dampers are mounted on the base plate of the CMBE TWIN booster. We also recommend to support the pipes with a vibration damper.

Type	Product Numbers
Vibration dampers	PN 99217259

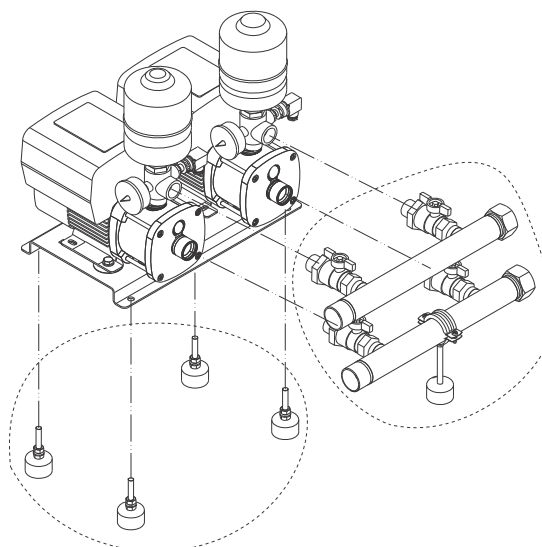

Fig. 21 Vibration damper kit (left) and inlet/outlet pipe kit (right) for the CMBE TWIN booster

TM05 5088 3212 - TM05 5087 3212

TM05 5085 3212 - TM05 5086 3212

TM06 8740-1017

11. Grundfos Product Center

Online search and sizing tool to help you make the right choice.

<http://product-selection.grundfos.com>



"SIZING" enables you to size a pump based on entered data and selection choices.

"REPLACEMENT" enables you to find a replacement product. Search results will include information on the following:

- the lowest purchase price
- the lowest energy consumption
- the lowest total life cycle cost.

The screenshot shows the website's navigation bar with 'HOME', 'FIND PRODUCT', 'COMPARE', 'YOUR PROJECTS', 'SAVED ITEMS', and 'HELP'. Below is a search bar with a 'SEARCH' button. A row of four main navigation buttons is visible: 'SIZING' (Enter pump sizing), 'CATALOGUE' (Products and services), 'REPLACEMENT' (Replace an old pump with a new), and 'LIQUIDS' (Find pump by liquid). The 'QUICK SIZING' section includes input fields for 'Flow (Q)*' (m³/h) and 'Head (H)*' (m), radio buttons for 'Select what to size by' (application, pump design, pump family), and a 'START SIZING' button. At the bottom, there are links for 'ADVANCED SIZING' with options for 'Advanced sizing by application' and 'Guided selection'.

"CATALOGUE" gives you access to the Grundfos product catalogue.

"LIQUIDS" enables you to find pumps designed for aggressive, flammable or other special liquids.

All the information you need in one place

Performance curves, technical specifications, pictures, dimensional drawings, motor curves, wiring diagrams, spare parts, service kits, 3D drawings, documents, system parts. The Product Center displays any recent and saved items - including complete projects - right on the main page.

Downloads

On the product pages, you can download installation and operating instructions, data booklets, service instructions, etc. in PDF format.

Subject to alterations.

be think innovate

98484486 0417

ECM: 1207589

GRUNDFOS A/S
DK-8850 Bjerringbro . Denmark
Telephone: +45 87 50 14 00
www.grundfos.com

GRUNDFOS 

The name Grundfos, the Grundfos logo, and be think innovate are registered trademarks owned by Grundfos Holding A/S or Grundfos A/S, Denmark. All rights reserved worldwide. © Copyright Grundfos Holding A/S