

Pit Pig

Polyethylene Pump Stations

- ***Sewer / Stormwater Applications***
- ***Single and Dual Pump Systems***
- ***Guide Rail and Free Standing Arrangement***



Choice of Access Covers

600L to 3000L volume with larger sizes on request

Selection of PVC, bronze or stainless steel valves available.

PVC pipework for a long, maintenance free life.

Heavy-duty submersible sewerage or stormwater pumps. Many options available.

Optional guide rails with auto-couplings for quick removal and reinstallation of pumps

Roto moulded polyethylene tank with heavy duty ribbing adds strength and assists in anti-floatation

Float switch and level probe options available for reliable pump control

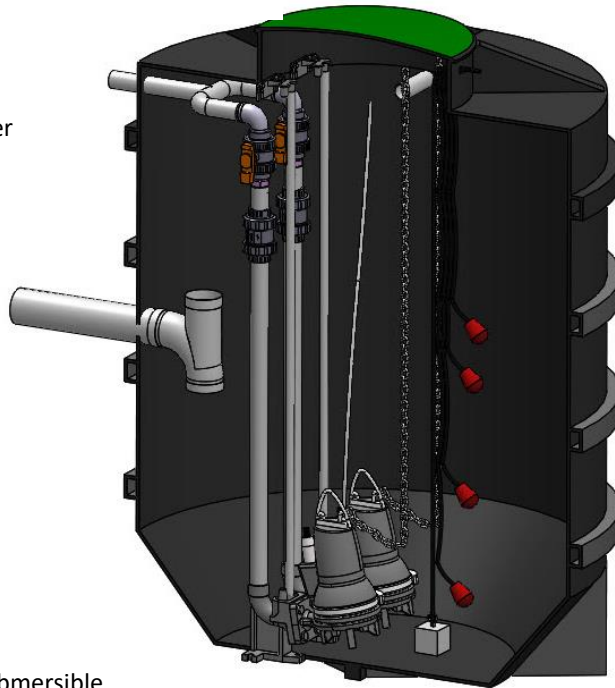

Single and Dual Pump Controllers



600L	Dia 1200mm x H 795mm
900L	Dia 1200mm x H 1195mm
1200L	Dia 1200mm x H 1555mm
2000L	Dia 1120mm x H 2400mm
3000L	Dia 2300 x H 2200mm

