

SV 300/1 ATEX

Side channel blowers

- single stage, air-cooled
- with pedestal

Seitenkanal-Verdichter

- einstufig, luftgekühlt
- mit Standfuß

Soufflantes à canal latéral

- mono-étagées, refroidies par air
- avec pied

Soffianti a canale laterale

- monostadio, raffreddate ad aria
- con piedistallo

Compresores de canal lateral

- una etapa, refrigerado por aire
- con pie



SV 300/1 incl. pedestal and optional rubber buffers

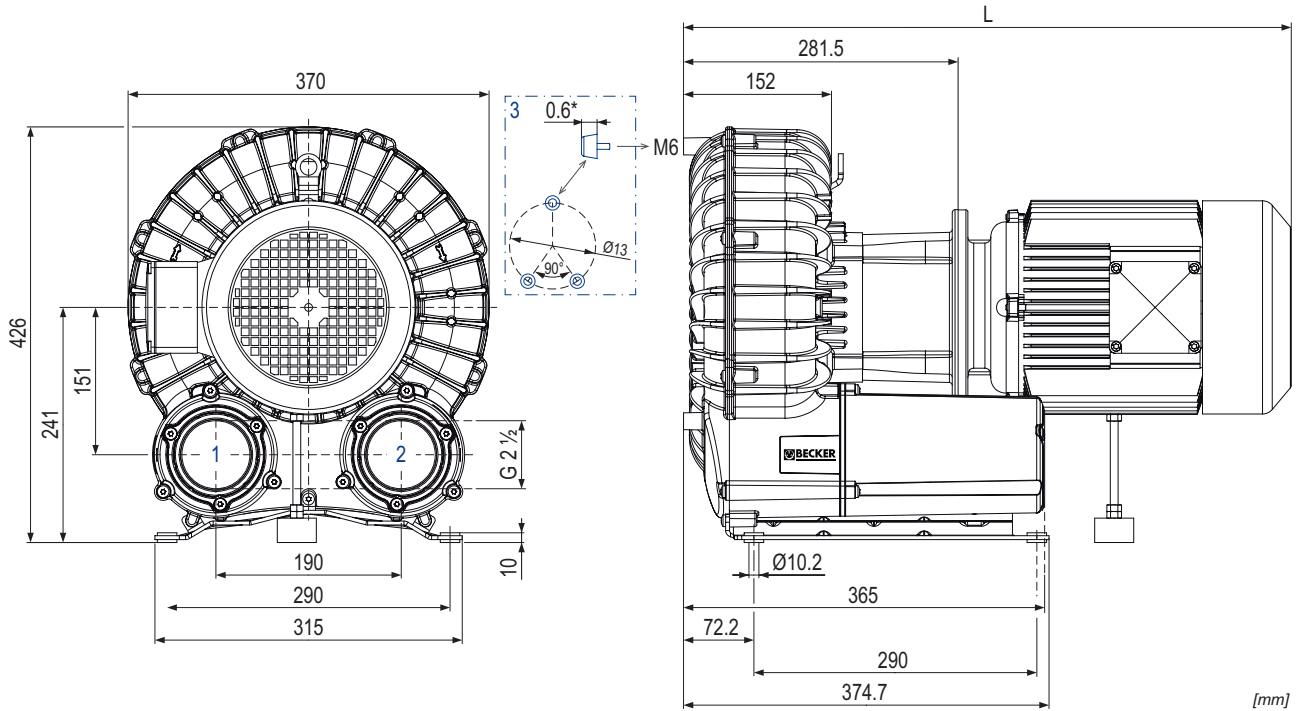

- | | | |
|--|--|--|
| <p>1 Vacuum connection
Sauganschluss
Raccord vide
Raccordo aspirazione
Conexión de vacío</p> | <p>2 Pressure connection
Druckanschluss
Raccord pression
Raccordo pressione
Conexión presión</p> | <p>3 Rubber buffer position (optional)
Gummipufferposition (optional)
Position de tampon en caoutchouc (optionnel)
Posizione del respingente in gomma (opzionale)
Posición del tope de goma (opcional)</p> |
|--|--|--|

ATEX	m ³ /h		mbar rel.		kW 3~		M	dB(A) ¹⁾		no. SV + M
	50 Hz	60 Hz	50 Hz	60 Hz	50 Hz	60 Hz		50 Hz	60 Hz	
II 3G/3G c IIB 125 (T3)	325	-	+250	-	3.3	-	1	71 (+165 mbar)	-	G020452
II 3D c IIB 125 (T3)	325	-	+250	-	3.3	-	2	71 (+165 mbar)	-	G020896

M	kW		V ±10%		min ⁻¹		A		no. IP55 • ISO F	L mm	kg SV + M
	50 Hz	60 Hz	50 Hz	60 Hz	50 Hz	60 Hz	50 Hz	60 Hz			
1	3.3	-	Δ230/Y400	-	2830	-	10.4/6.0	-	42435201300000AA	625	≈ 60
2	3.3	-	Δ230/Y400	-	2830	-	10.4/6.0	-	42435201300074AA	625	≈ 60

- | | | | | |
|---|---|---|---|--|
| 1) DIN EN ISO 3744 (KpA = 3 dB(A))
interval of 1 m, at medium load, both
connection sides piped | DIN EN ISO 3744 (KpA = 3 dB(A))
Abstand von 1 m, bei mittlerer
Belastung, beide Seiten abgeleitet | DIN EN ISO 3744 (KpA = 3 dB(A))
intervalle de 1 m, à régime moyen,
avec dérivation des deux côtés | DIN EN ISO 3744 (KpA = 3 dB(A))
intervallo di 1 m, a medio regime,
entrambi i lati derivati | DIN EN ISO 3744 (KpA = 3 dB(A))
intervalo de 1 m, en media carga,
derivados de ambos lados |
| • Dimensions in mm | Maßangaben in mm | Mesures en mm | Misure in mm | Dimensiones en mm |



WWW.BECKER-INTERNATIONAL.COM

Right of modification reserved
Anderungen vorbehalten
Sous réserve des modifications
Sotto riserva di modificazioni
Derecho a modificaciones reservado

23.06.2018

Blast air rate • Blasluftmenge • Débit d'air soufflé • Volume d'aria soffiata • Volumen de aire soplado

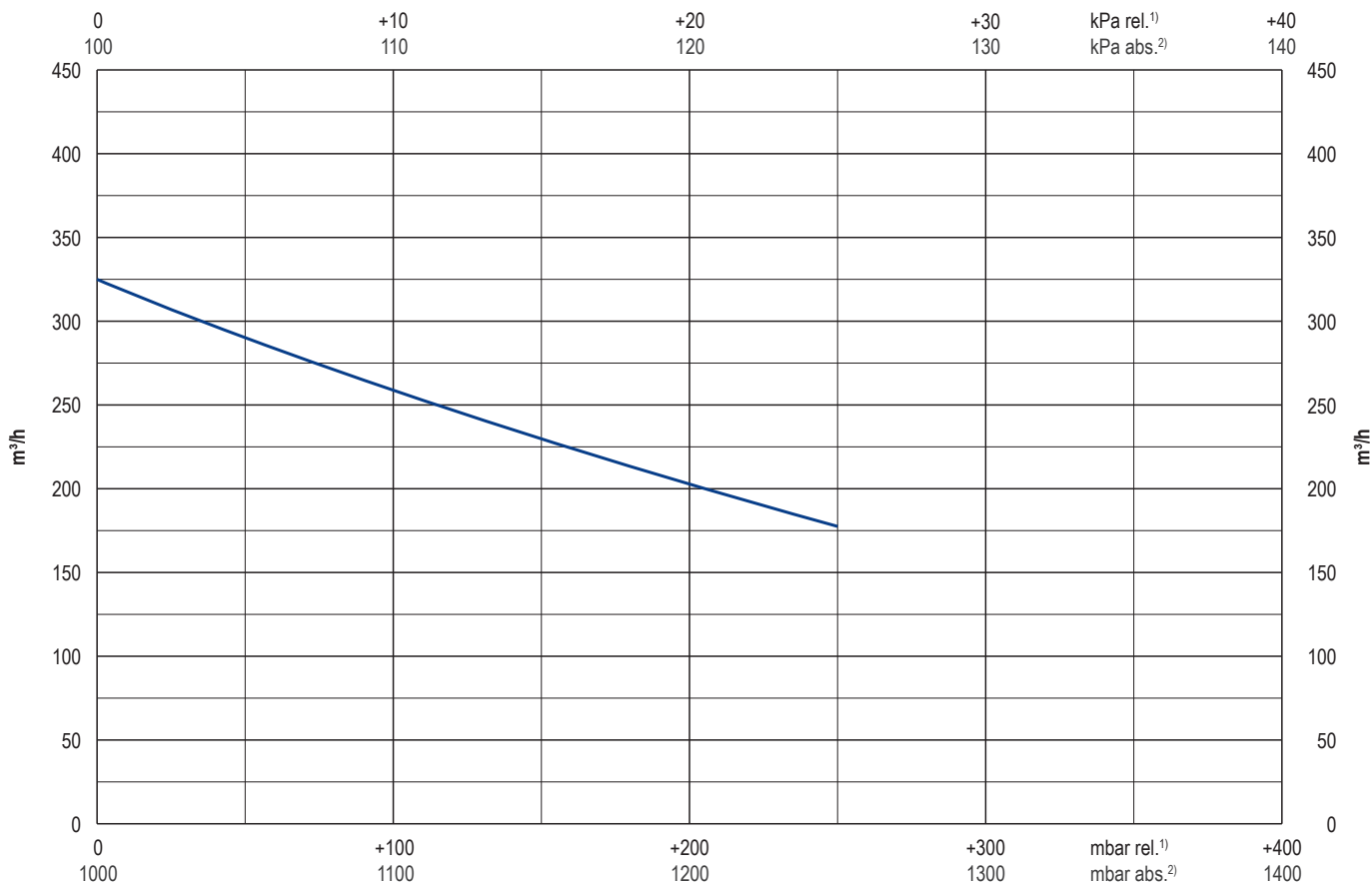

Exhaust air temperature • Ablufttemperatur • Température d'air à l'échappement
Temperatura dell'aria scarica • Temperatura del aire de escape

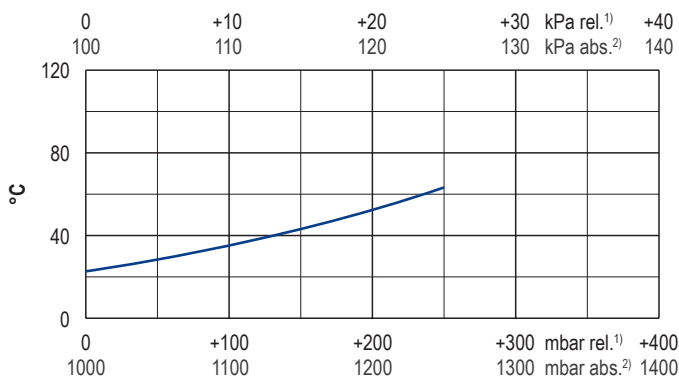

Motor shaft power • Wellenleistung • Puissance du moteur axe
Potenza del motore albero • Capacidad de eje del motor

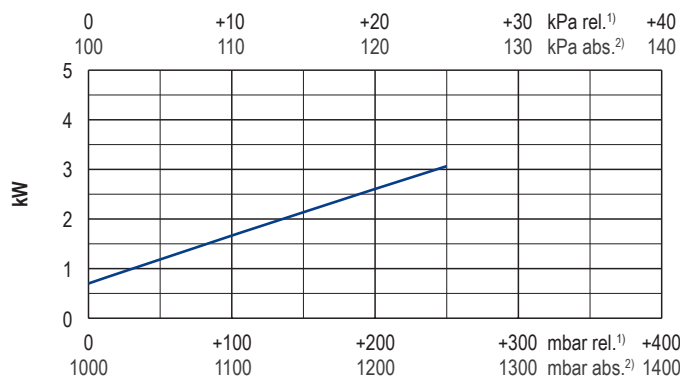

— 50 Hz	¹⁾ relative / ²⁾ absolute	¹⁾ relativ / ²⁾ absolut	¹⁾ relatif / ²⁾ absolu	¹⁾ relativo / ²⁾ assoluto	¹⁾ relativa / ²⁾ absoluta
- - 60 Hz					
1000 mbar, 20°C	Reference data (atmosphere)	Bezugsdaten (Atmosphäre)	Référence (atmosphère)	Riferimento (atmosfera)	Referencia (atmosférica)
± 10 %	Tolerance	Toleranz	Tolérance	Tolleranza	Tolerancia
≤ 45°C	Max. ambient temperature	Max. Umgebungstemperatur	Max. température ambiante	Max. temperatura ambiente	Max. temperatura ambiente

Variants/Accessories

without ATEX – as standard pump for 50/60Hz operation or

Varianten/Zubehör

ohne ATEX – als Standardpumpe für 50/60Hz Betrieb oder

Variantes/Accessoires

sans ATEX – comme une pompe standard pour un fonctionnement 50/60Hz ou

Varianti/Accessori

senza ATEX – come una pompa standard per 50/60Hz o

Variantes/Accesorios

sin ATEX – como una bomba estándar para la operación 50/60Hz o



with frequency inverter

Performance data / dimensions can differ
Combinations on request

mit Frequenzumrichter

Leistungsdaten / Abmessungen können abweichen
Kombinationen auf Anfrage

avec convertisseur de fréquence

Données de performance / mesures peuvent différer
Combinaisons sur demande

con convertitore di frequenza

Dati di performance / misure possono differire
Combinazioni su richiesta

con variador de frecuencia

Datos de rendimiento / dimensiones pueden diferir
Combinaciones a petición



WWW.BECKER-INTERNATIONAL.COM

Right of modification reserved /
Änderungen vorbehalten
Sous réserve des modifications
Sotto riserva di modificazioni
Derecho a modificaciones reservado

23.06.2018