

Magnet drive gear pump-motor units MGCF04S/MGCF11S series

The compact precision performance pumps MG or PG series are designed to fit high technology applications. The magnet drive principle provides a totally sealed pump chamber which is capable of handling a wide range of corrosive fluids with a high degree of safety. The pump housing is available in AISI 316L, SAF 2205, AISI 303 or PPS. In operation the MG and PG series pumps are noiseless, pulsation-free and capable of handling relatively high temperature liquids up to 120 °C (248 F). The coupling with the MGCF04S, MGCF11S units designed for heavy duty, provides a reliable and noiseless operation in a compact size package. The pole-to-pole alignment of the two magnets provides the driving motion to the pump. Decoupling will occur when the pump load exceeds the coupling torque between the magnets.



MAIN APPLICATIONS

- Medical and surgical equipment
- Hemodialysis apparatus
- Laser apparatus
- Lubrication
- Ink-jet printing systems
- Cooling systems
- Laboratory instrumentation
- Water purification and ultra-filtration
- Sampling
- Food processing equipment



MGCF04S-MGCF11S

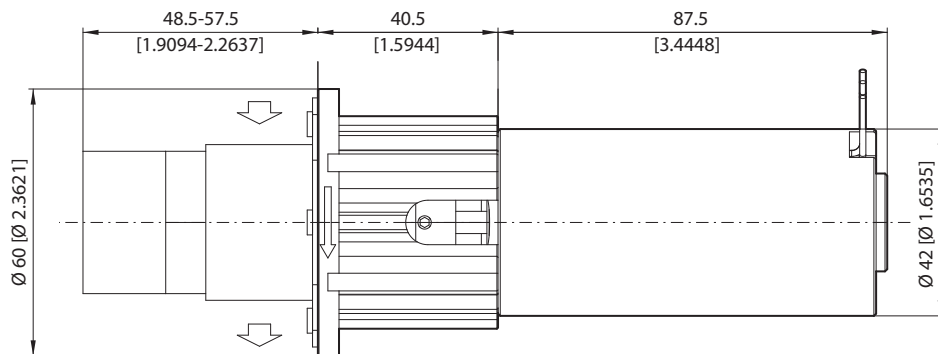

Dimensions in mm [inches]

Magnet drive gear pump-motor units MGCF04S/MGCF11S series

POS	DESCRIPTION	FEATURES	CODE
A	Driving magnet	For 5 mm bore	MGAF05S
A+B	Complete adapter	For KAG M42x30	MGBF42S
A+B+C	Complete motor assembly	See table below	MGCF04S MGCF11S

DRIVING UNIT	MGCF04S	MGCF11S
Voltage (V)	12 DC	24 DC
Rated speed (rpm)	3300	3000
Current consumption (A)	3.4	1.5
Output power (W)	25.9	23.6
Weight (g)	700	700

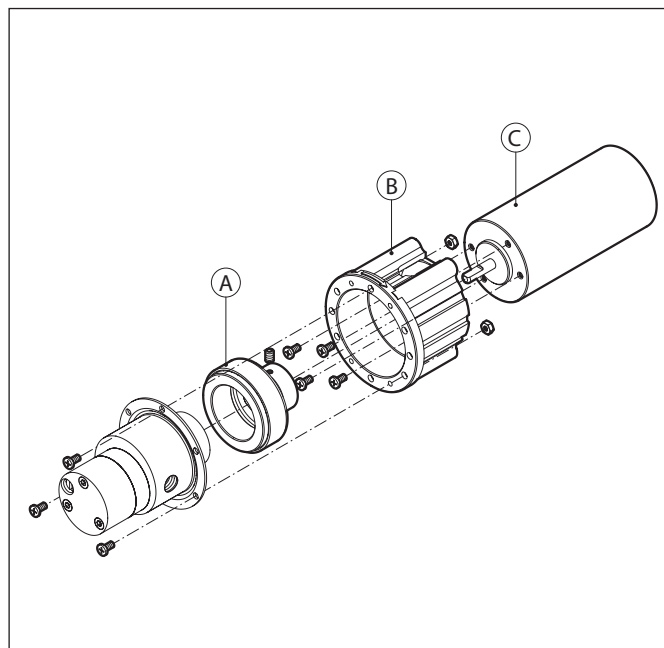

MGCF04S

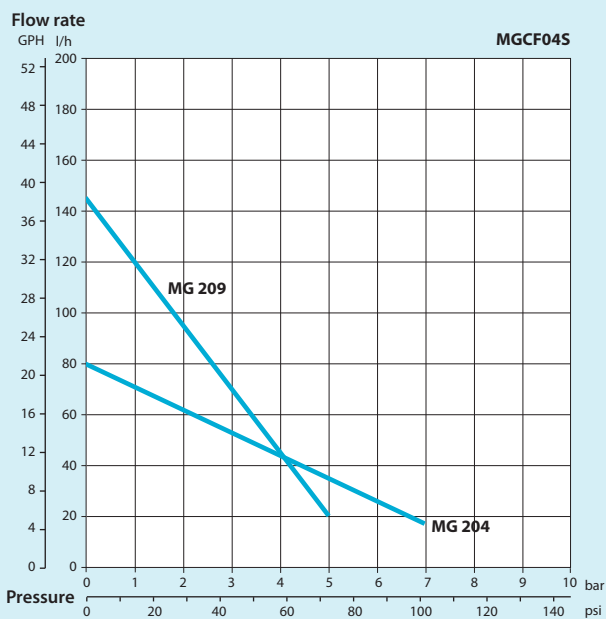

MGCF11S

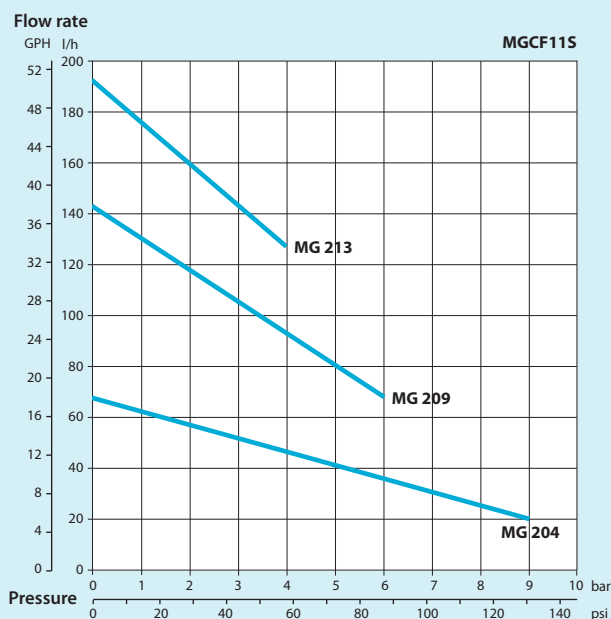

Note: Characteristics with water at 20 °C (68 F) and without relief valve, max vacuum 724 mmHg. Use filter before pump inlet not larger than 10 micron. Unit weight: 1.1 kg (2.4 Lb). Temperature requirements different from ambient temperature must be mentioned on the order.

Fluid-o-Tech reserves the right to alter the specifications indicated in this catalogue at any time and without prior notice.

Fluid-o-Tech srl
Via Leonardo da Vinci, 40
20094 Corsico, Milano, Italy
Tel. +39 02 9995 01
Fax +39 02 9995 0999
info@fluidotech.it

Fluid-o-Tech Int'l Inc.
161 Atwater St.,
06479 Plantsville CT (USA)
Tel. +1 (860) 276 9270
Fax +1 (860) 620 0193
info@fluid-o-tech.com

Fluid-o-Tech Int'l Inc. Japan
201, 4-3-10, Todoroki,
Setagaya, Tokyo 158-082, Japan
Tel. +81 (0) (3) 6432 1812
Fax +81 (0) (3) 6432 1813
erkkato@fluidotech.jp

Fluid-o-Tech Asia (Beijing) Co., Ltd
Jingwei Industrial Zone,
Beifang Huairou, Beijing, 101400, PRC
Tel. +86 (0) (10) 6168 4650
Fax +86 (0) (10) 6168 4651
info@fluidotech-asia.com