

**seepex.com**  
all things flow

Here is your conveying solution:  
Product group E.



# E – Semi-submersible pumps

Semi-submersible pumps are installed vertically. They pump liquids of different viscosities, which may be abrasive or even corrosive. Due to their high efficiencies, a minimal footprint and their maintenance-friendly design, seepex semi-submersible pumps have low life-cycle costs and are a viable alternative to other pump systems.

**Plug-in shaft**  
connects the drive shaft to the joint.

**Lantern**  
for connection of pump and drive.

**Pressure casing**  
with connections for pressure/vacuum gauge and mounting plate for fixing the pump. Flange connections in DIN or ANSI. Length according to customers specification.

**Universal joint sleeve with holding bands**  
protects the grease-filled joints from penetration of the liquid pumped, even in case of maximum pressure loading. Streamlined design to reduce turbulence and NPSHr.

**Tie bolts/screws**  
corrosion proof, optionally available in stainless steel design.

**Rotor**  
wear resistant and corrosion-proof materials, with additional surface treatment.

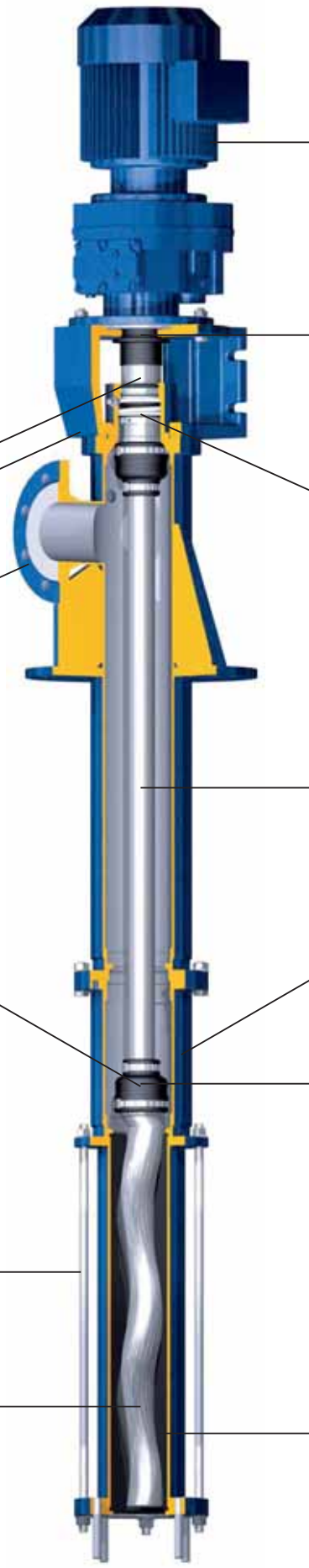

---

**Drive**

geared motors, variable speed drives or hydraulic motors of all major manufacturers, directly flanged to the pump without additional couplings or guards.

---

**Plug-in shaft connection**

for easy dismantling of the pump and drive enabling quick replacement of the rotating parts and shaft seals. The plug-in shaft pin secures the shaft connection to the drive and the splash ring protects the bearing from contamination/gland leakage.

---

**Shaft sealing**

single-acting mechanical seal, independent of direction of rotation, with quench and supply tank (78 cm<sup>3</sup>-4 l) to protect the sliding surface against dry running.

(see detail)

---

**Coupling rod**

for power transmission; improved design.

---

**Intermediate housing**

for quick assembly of rotor and stator used for submersible depths above 3 m (10ft).

---

**Joint connection**

consisting of just 5 components. Power transmission through wear resistant, hardened and replaceable joint parts: easily repaired.

---

**Stator**

the seal on both ends is moulded as an integral part of the elastomeric stator; corrosion of the stator tube is never a problem because the pumped liquid never comes into contact with the metal tube or the bonding adhesive.

**Detail: Shaft sealing**

# Why semi-submersible pumps?

Because they are used in applications such as automotive industry, construction, chemical and biochemical industry, dyeing and varnishing industry, electroplating, fish industry, fruit and vegetable processing, metering of chemical additives, oil, gas and petrochemical industry, shipbuilding, supply industry, textile industry, wood processing and waste water and sludge treatment.

## Features

- Service-friendly with a standard atmospherically cooled drive
  - Customised lengths
  - Various installation configurations are available to suit the most unusual applications
  - Space-saving construction
  - Overcomes NPSHa limitations
- > Conveying capacity: up to 300 m<sup>3</sup>/h (1300 GPM),  
Pressure: up to 12 bar (180 psi)

# Overview of ranges

seepex semi-submersible pumps of the BE range, available in the semi-submersible variants crane suspension, wall-mounting, circular mounting plate with pressure branch on top or on the bottom are suited for draining clarifiers, sumps, tanks, pits and containers of all types. Using gas-tight circular mounting plates, the pumps can be installed in closed systems and thus facilitate complying with the strict environmental protection regulations.

**Range BE**  
Submersible variant U

Pressure branch below the circular mounting plate

---

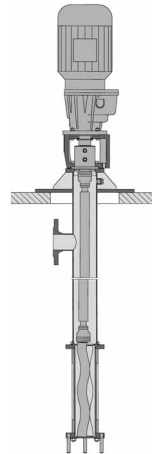

**Range BE**  
Submersible variant O

Pressure branch above the circular mounting plate

---

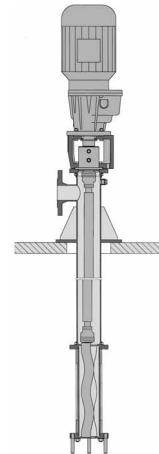

**Range BE**  
Submersible variant K

Crane suspension device

---

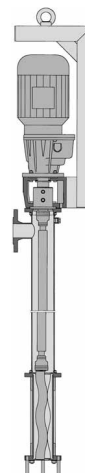

**Range BE**  
Submersible variant W

Wall mounting

---

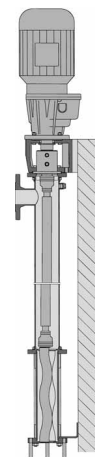

**seepex.com**  
all things flow

And what can we get flowing for you? Your nearest contact:

Or visit [www.seepex.com](http://www.seepex.com)

E 8.06E