

# KE/KS KW/KM

AUTOMATIC BAR SCREENS



# Main parts made of stainless steel Excellent corrosion resistance

## Structure of Screen (Example of Front Screen)

When installed in a ditch, the screen catches solid matters contained in the sewage and allows water to pass. The solid matters caught by the screen is raised with rakes, and collected in the residue collecting basket.

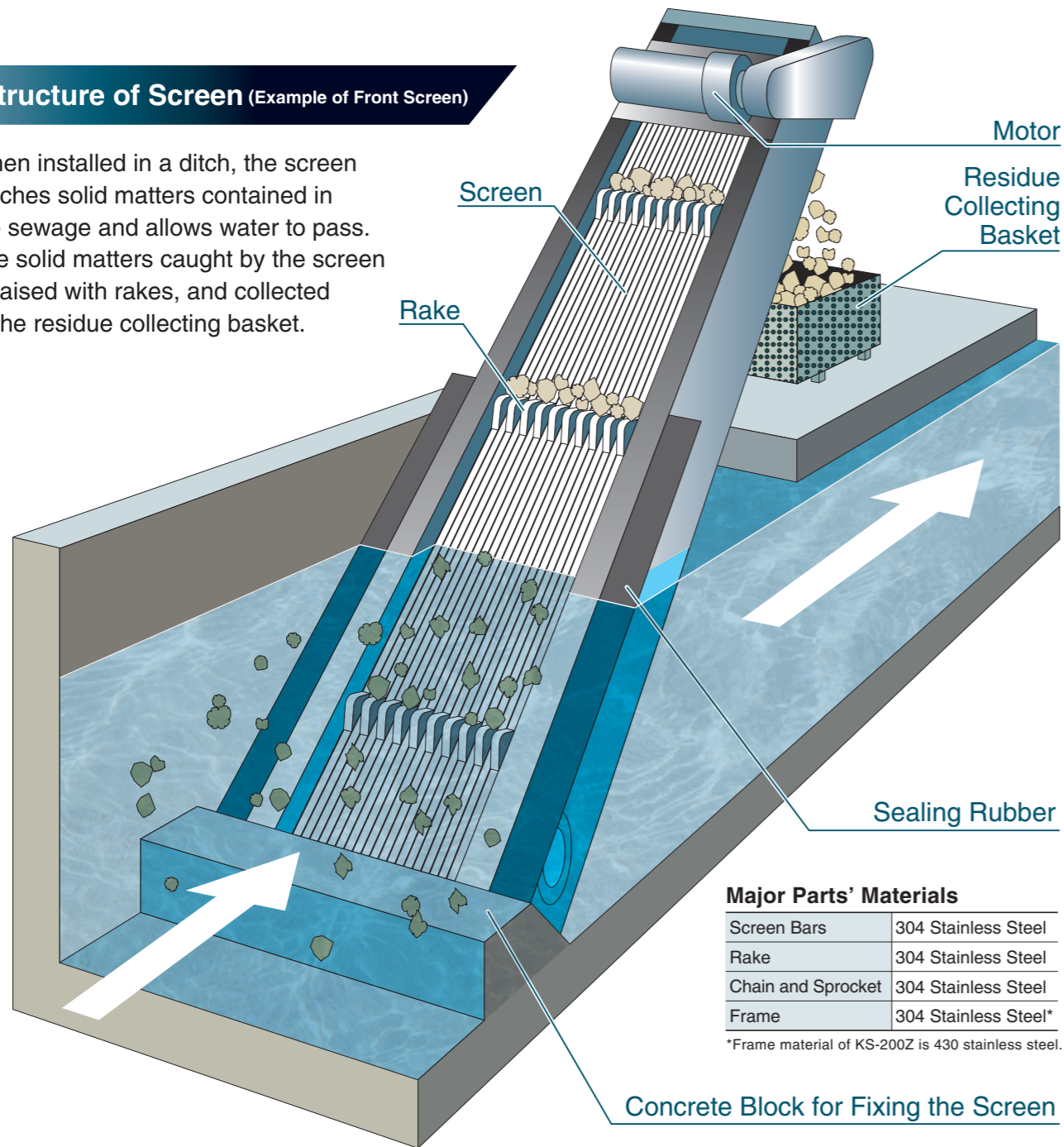

### Major Parts' Materials

Screen Bars	304 Stainless Steel
Rake	304 Stainless Steel
Chain and Sprocket	304 Stainless Steel
Frame	304 Stainless Steel*

\*Frame material of KS-200Z is 430 stainless steel.

Used for combined sewage treatment tank (Johkasou/septic tank) and small-scale sewage treatment facilities, etc.

## Efficient Elimination of Floating Solid Matters in Sewage

Tsurumi bar screens are pre-treatment equipment that enables smooth water treatment in post-processes.

Front Screen Type

**KE/KS/KW**

Rear Screen Type

**KM/KMA/KMS**

### Applications

- Primary treatment of general industrial wastewater
- Treatment of wastewater from food processing factories
- Treatment of kitchen wastewater from hotels, factories, hospitals, etc.
- Combined sewage treatment tanks (Johkasou/septic tank)
- Village wastewater treatment facilities
- Small-scale sewage treatment facilities

Front Screen Type **KE/KS/KW**

### Application in situations with water level fluctuations

- The bar screen is compact and lightweight, making it easy to install in U-shaped ditches, etc. With sealing rubber attached to the sides of the frame, the screen snugly fits any width of waterway.
- During operation, the rakes always move through the slits of the screen, preventing the screen from being clogged with foreign object.
- The main parts are made of 304 stainless steel, which exhibits excellent durability even in harsh environments, e.g., outdoors, continuously operated day and night, etc.
- Maintenance is easy. Initial and running costs are low.
- The KS-series screens are equipped with an eccentric roll mechanism that prevents retraction and clogging of the screen bar front edge caused by residue.
- The KW-series screens incorporate a safety device that can stop the gear motor immediately in the event of abnormal operation.



KE

Rear Screen Type **KM/KMA/KMS**

### Application in situations without water level fluctuations

- The bar screen is compact and lightweight, making it easy to install in U-shaped ditches, etc. With sealing rubber attached to the sides of the frame, the screen snugly fits any width of waterway.
- Since the rake chain (dry chain) is not in contact with liquid, dirt and residue will not adhere to it. Therefore, it needs almost no maintenance.
- The main parts are made of 304 stainless steel, which exhibits excellent durability even in harsh environments, e.g., outdoors, continuously operated day and night, etc.
- The bar screen can be directly installed in a U-shaped ditch to eliminate dirt from the bottom of the ditch. It provides excellent treatment effect, and is advantageous both in terms of initial cost and running costs.

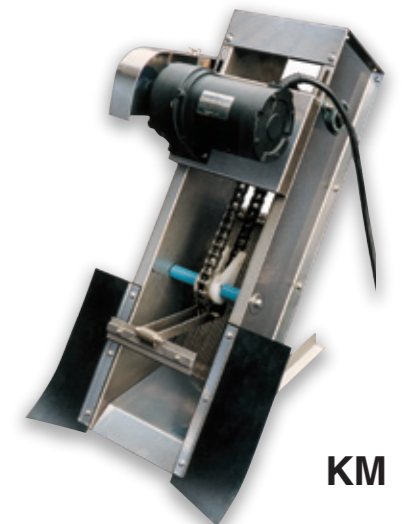

KM

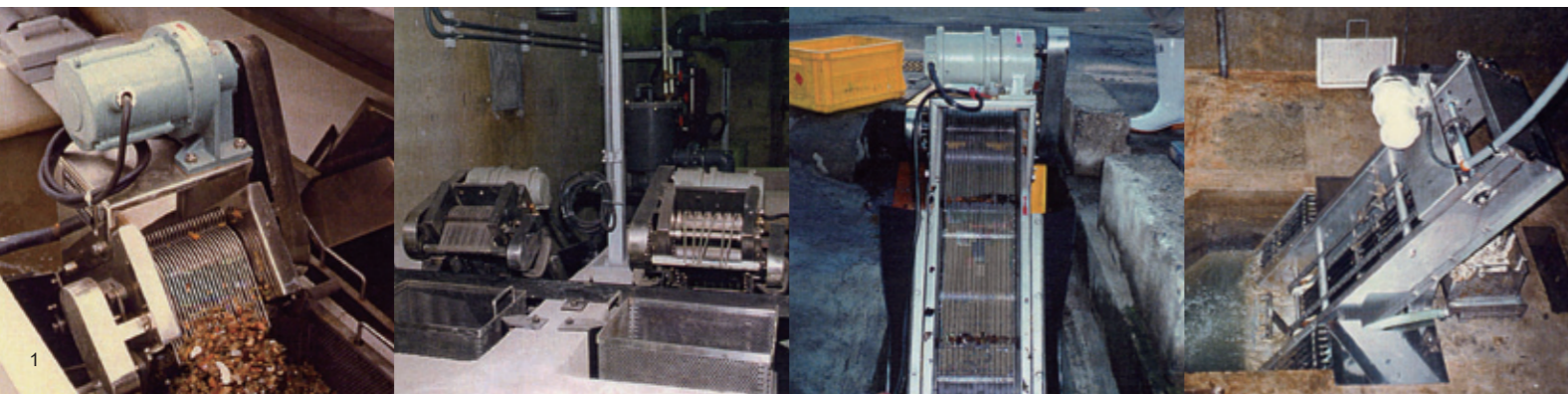

# KE/KS/KW –Front Screen–

The KE/KS/KW-series is a front screen type automatic bar screen designed for screening wastewater. It is fully constructed from 304 stainless steel. Two or more rakes travel behind the screen bars located at the front side of the unit. Since every rake tooth moves between the screen bars, it can remove solid matters even though they lodge between the screen bars. In addition, the use of a small output motor enables to save the electricity. The bar screen is suitable for use in a waterway with varying water levels.

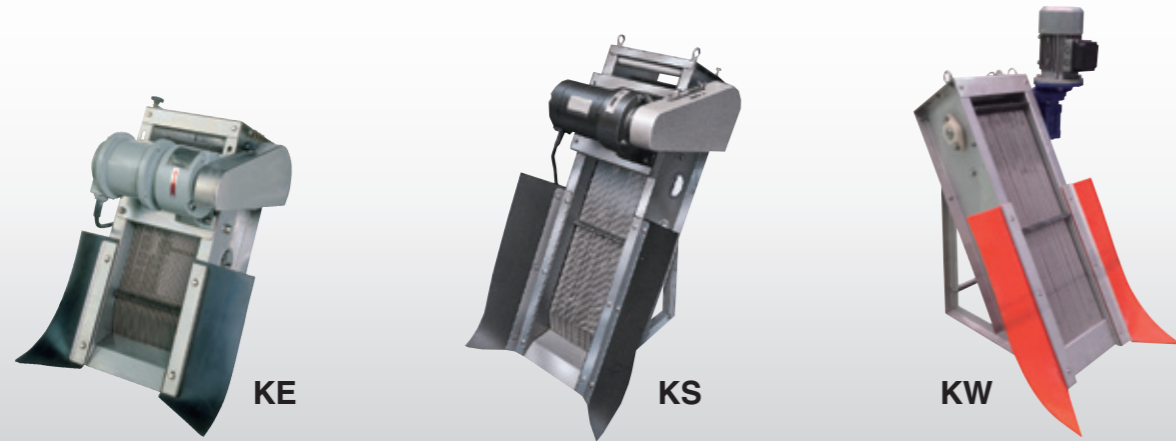

## Fine Screen (Bar Spacing: 1.0 - 5.0mm)

Model	Motor Output kW	Bar Spacing mm				Overall Height mm	Width of Waterway mm	Installation Angle	Dry Weight kg
		Capacity m³/h							
		1.0mm	2.0mm	2.5mm	5.0mm				
KE-200S	0.1	—	26	31	41	510	300 - 400	60°	32
KE-200M	0.1	—	36	46	58	685	300 - 400	60°	38
KE-200L	0.1	—	49	62	78	865	300 - 400	60°	42
KS-200Z	0.1	16	26	31	41	520	330 - 400	60°	33
KS-200Y	0.1	29	47	56	74	760	400 - 500	60°	49
KS-300Y	0.1	43	70	84	110	760	500 - 600	60°	54
KS-200S	0.1	17	28	31	47	800	330 - 400	45°	47
KS-200M	0.1	25	41	48	70	920	330 - 400	45°	52
KS-200L	0.1	32	55	63	93	1050	330 - 400	45°	62
KW-4027	0.09	17	29	34	47	659	up to 400	60°	23.5
KW-4038	0.09	27	45	52	73	842	up to 400	60°	27.8
KW-4049	0.09	39	66	76	105	1057	up to 400	60°	31.8
KW-5027	0.09	26	45	52	73	659	400 - 500	60°	27.0
KW-5038	0.09	41	69	81	113	842	400 - 500	60°	32.1
KW-5049	0.09	60	101	117	164	1057	400 - 500	60°	37.1
KW-6027	0.09	36	61	70	98	659	500 - 600	60°	30.5
KW-6038	0.09	56	95	109	153	842	500 - 600	60°	36.5
KW-6049	0.09	81	138	158	223	1054	500 - 600	60°	42.3

## Coarse Screen (Bar Spacing: 20 - 50mm)

Model	Motor Output kW	Bar Spacing mm				Overall Height mm	Width of Waterway mm	Installation Angle	Dry Weight kg
		Capacity m³/h							
		20mm	30mm	40mm	50mm				
KS-200S	0.1	70	75	80	85	800	330 - 400	45°	47
KS-200M	0.1	104	111	119	123	920	330 - 400	45°	52
KS-200L	0.1	137	147	157	165	1050	330 - 400	45°	62

- Powered by three-phase totally-enclosed geared motor.
- Capacity is given as the maximum amount of clean water.
- Consult your dealer if the screen is to be installed in a waterway of a width exceeding that listed on the table.
- When ordering, specify the desired bar spacing together with the model name.

## Dimensions

KE-200S  
KE-200M  
KE-200L

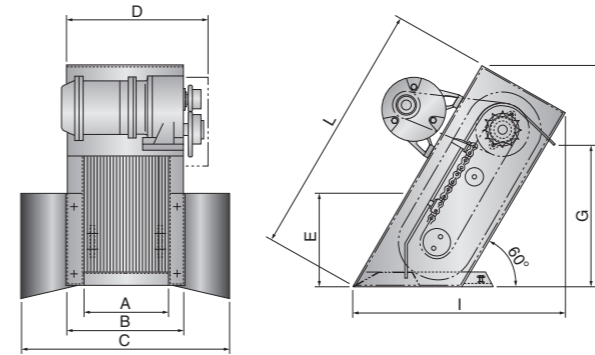

KS-200Z  
KS-200Y  
KS-300Y

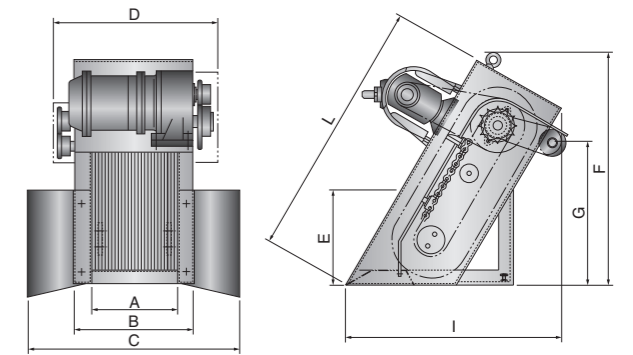

KS-200S  
KS-200M  
KS-200L

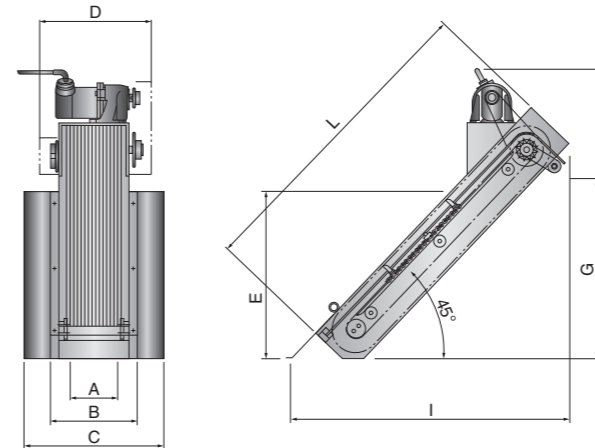

KW-4027 KW-5027 KW-6027  
KW-4038 KW-5038 KW-6038  
KW-4049 KW-5049 KW-6049

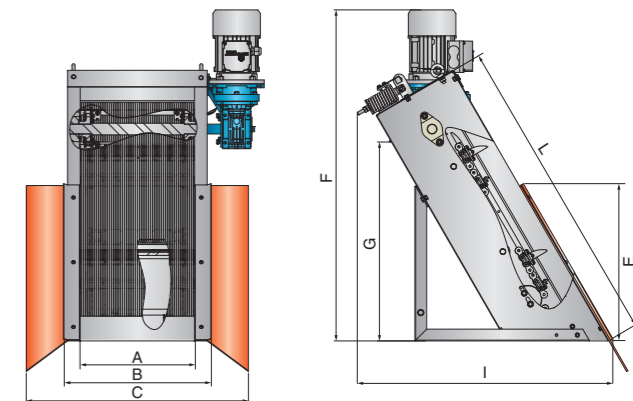

Model	Effective Width A	Width of Frame B	Overall Width C	Max. Width of Upper Part D	Max. Water Level E	Overall Height F	Discharge Level of Solids G	Space I	Unit: mm	
									Overall Length of Frame L	
KE-200S	191	254	460	330	210	510	300	480	577	
KE-200M	191	254	460	330	390	685	500	580	787	
KE-200L	191	254	460	330	510	865	680	690	992	
KS-200Z	191	254	460	350	210	520	280	490	577	
KS-200Y	191	254	460	350	360	760	500	640	850	
KS-300Y	282	345	550	500	360	760	500	640	850	
KS-200S	180(187)	290(297)	500	400(410)	270	800	400	800	800	
KS-200M	180(187)	290(297)	500	400(410)	370	920	540	920	971	
KS-200L	180(187)	290(297)	500	400(410)	470	1050	650	1040	1140	
KW-4027	191	276	465	410	279	659	323	544	584	
KW-4038	191	276	465	410	395	842	506	650	795	
KW-4049	191	276	465	410	511	1057	722	774	1044	
KW-5027	291	376	565	510	279	659	323	544	584	
KW-5038	291	376	565	510	395	842	506	650	795	
KW-5049	291	376	565	510	511	1057	722	774	1044	
KW-6027	391	476	665	610	279	659	323	544	584	
KW-6038	391	476	665	610	395	842	506	650	795	
KW-6049	391	476	665	610	511	1057	722	774	1044	

• Figure in ( ) are for the screens of 5mm or coarser bar spacing.

# KM –Rear Screen–

The KM-series is a rear screen type automatic bar screen designed for screening wastewater. It is fully constructed from 304 stainless steel. One or two rakes move on the screen bars that are located at the rear side of the unit. It has an innovative dry chain mechanism by which the chain or sprocket does not get contact with the liquid. In addition, the use of a small output motor enables to save the electricity. It is suitable for use in a waterway where there is little change in the liquid level.

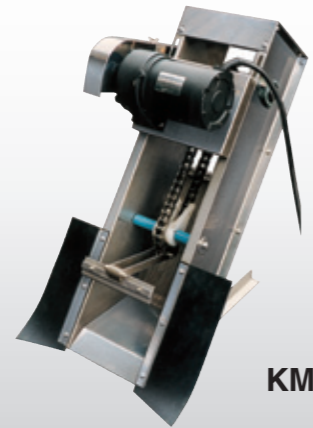

**KM**

## Fine Screen (Bar Spacing: 2.0 - 5.0mm)

Model	Motor Output kW	Bar Spacing mm			Overall Height mm	Width of Waterway mm	Installation Angle	Dry Weight kg
		Capacity m³/h						
		2.0mm	2.5mm	5.0mm				
KM-200S	0.1	25	28	39	720	300 - 400	55°	33
KM-200M	0.1	25	28	39	910	300 - 400	55°	37
KM-200L	0.1	25	28	39	1110	300 - 400	55°	40
KM-250S	0.1	32	38	53	720	350 - 450	55°	34
KM-250M	0.1	32	38	53	910	350 - 450	55°	38
KM-250L	0.1	32	38	53	1110	350 - 450	55°	41
KM-300S	0.1	40	46	64	720	400 - 500	55°	35
KM-300M	0.1	40	46	64	910	400 - 500	55°	39
KM-300L	0.1	40	46	64	1110	400 - 500	55°	42
KMS-300S	0.1	—	—	63	870	400 - 500	60°	42
KMS-300M	0.1	—	—	63	1215	400 - 500	60°	50
KMS-300L	0.1	—	—	63	1560	400 - 500	60°	57

## Coarse Screen (Bar Spacing: 10 - 50mm)

Model	Motor Output kW	Bar Spacing mm					Overall Height mm	Width of Waterway mm	Installation Angle	Dry Weight kg
		Capacity m³/h								
		10mm	20mm	30mm	40mm	50mm				
KMA-200S	0.1	38	45	47	49	50	720	300 - 400	55°	33
KMA-200M	0.1	38	45	47	49	50	910	300 - 400	55°	37
KMA-200L	0.1	38	45	47	49	50	1110	300 - 400	55°	40
KMA-250S	0.1	48	56	59	61	62	720	350 - 450	55°	34
KMA-250M	0.1	48	56	59	61	62	910	350 - 450	55°	38
KMA-250L	0.1	48	56	59	61	62	1110	350 - 450	55°	41
KMA-300S	0.1	58	67	71	74	79	720	400 - 500	55°	35
KMA-300M	0.1	58	67	71	74	79	910	400 - 500	55°	39
KMA-300L	0.1	58	67	71	74	79	1110	400 - 500	55°	42
KMS-300S	0.1	75	89	89	95	100	870	400 - 500	60°	42
KMS-300M	0.1	75	89	89	95	100	1215	400 - 500	60°	50
KMS-300L	0.1	75	89	89	95	100	1560	400 - 500	60°	57

- Powered by three-phase totally-enclosed geared motor.
- Capacity is given as the maximum amount of clean water.
- Consult your dealer if the screen is to be installed in a waterway of a width exceeding that listed on the table.
- When ordering, specify the desired bar spacing together with the model name.

## Dimensions

**KM-200S**    **KMA-200S**  
**KM-200M**    **KMA-200M**  
**KM-200L**    **KMA-200L**  
**KM-250S**    **KMA-250S**  
**KM-250M**    **KMA-250M**  
**KM-250L**    **KMA-250L**  
**KM-300S**    **KMA-300S**  
**KM-300M**    **KMA-300M**  
**KM-300L**    **KMA-300L**

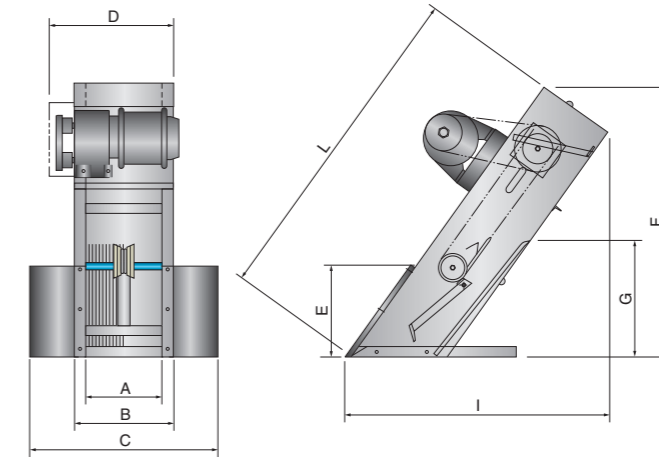

**KMS-300S**  
**KMS-300M**  
**KMS-300L**

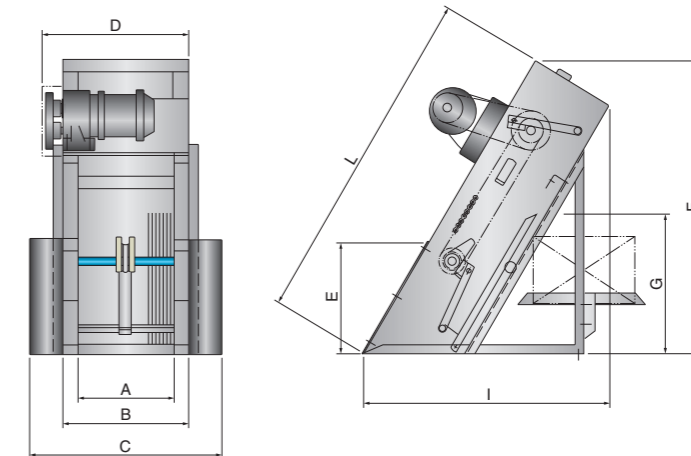

Unit: mm

Model	Effective Width A	Width of Frame B	Overall Width C	Max. Width of Upper Part D	Max. Water Level E	Overall Height F	Discharge Level of Solids G	Space I	Overall Length of Frame L
KM-200S	200	253	460	310	250	720	310	670	868
KM-200M	200	253	460	310	250	910	475	800	1102
KM-200L	200	253	460	310	250	1110	670	945	1352
KM-250S	250	303	510	360	250	720	310	670	868
KM-250M	250	303	510	360	250	910	475	800	1102
KM-250L	250	303	510	360	250	1110	670	945	1352
KM-300S	300	353	560	410	250	720	310	670	868
KM-300M	300	353	560	410	250	910	475	800	1102
KM-300L	300	353	560	410	250	1110	670	945	1352
KMA-200S	200	253	460	310	250	720	310	670	868
KMA-200M	200	253	460	310	250	910	475	800	1102
KMA-200L	200	253	460	310	250	1110	670	945	1352
KMA-250S	250	303	510	360	250	720	310	670	868
KMA-250M	250	303	510	360	250	910	475	800	1102
KMA-250L	250	303	510	360	250	1110	670	945	1352
KMA-300S	300	353	560	410	250	720	310	670	868
KMA-300M	300	353	560	410	250	910	475	800	1102
KMA-300L	300	353	560	410	250	1110	670	945	1352
KMS-300S	284	368	570	420	200	870	400	830	1000
KMS-300M	284	368	570	420	200	1215	730	996	1400
KMS-300L	284	368	570	420	200	1560	1040	1150	1800



We reserve the right to change the specifications and designs for improvement without prior notice.

**TSURUMI  
MANUFACTURING CO., LTD.**

Your Dealer