

Diesel Engine Driven



HYDRAULIC DRIVEN SLUDGE PUMP
HSK4A—KDI1903TCR FT4

Total Head		Capacity of Pump in U.S. Gallons per Minute (GPM)		
P.S.I.	Feet			
168.9	390	20	20	20
155.9	360	102	126	183
129.9	300	115	158	212
103.9	240	116	164	218
77.9	180	117	165	221
52.0	120	118	167	224
26.0	60	119	169	226
CYCLES (STROKES) PER MINUTE		30	40	50



SLUDGE PUMP SPECIFICATIONS

- Product Cylinder:** Chrome Plated Steel
- U—Ring:** Fluorocarbon Elastomers (DuPont Viton® or Equal)
- O—Ring:** Fluorocarbon Elastomers (DuPont Viton® or Equal)
- Wiper Seal:** Fluorocarbon Elastomers (DuPont Viton® or Equal)
- Victaulic Coupling:** Iron Gasket Housing w/Buna-N Gasket

HYDRAULIC SPECIFICATIONS

- Hose Ports:** 1 1/2" Split Flange Suction / 1" Split Flange Discharge
- Hydraulic Pump:** Pressure Compensated Piston Type.
- Maximum Operating Pressure:** 2000 PSI (138 Bar) Bypass.
- Hydraulic Oil:** SAE No. 30 Non-Detergent Oil of Equivalent.
- Hydraulic Oil Reservoir Capacity:** 40 U.S. Gallons (151 Liters).

PUMP MODEL SPECIFICATIONS

Standard Equipment: Wheel Kit With Electric Lights and Brakes, Lifting Bail, Combination Skid Base w/Fuel Tank, Pressure Control Valve, System Relief Valve, Spin-on Return Filter, Fluid Level/Temperature Gauge, Tank Top Filler/ Strainer, Variable Speed Control, Liquid Filled Pressure Gauge .

Optional Equipment: Battery

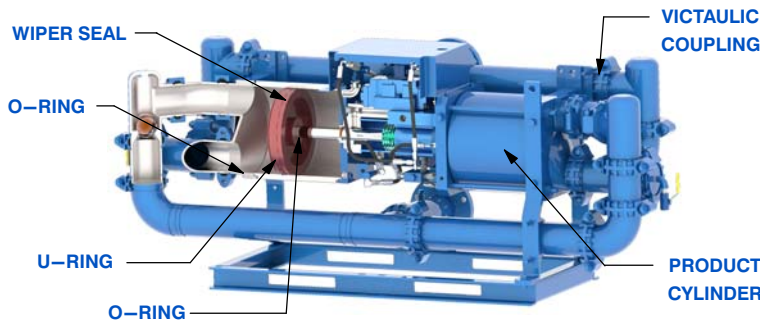

WARNING!
Do not use in explosive atmosphere or for pumping volatile flammable liquids.

ENGINE SPECIFICATIONS

- Model:** Kohler KDI1903TCR.
- EPA Tier:** Tier 4.
- Type:** Three Cylinder, Four Cycle, Turbocharged, Liquid Cooled Diesel Engine.
- Displacement:** 113.5 Cu. In. (1,9 Liters).
- Governor:** Electronic Isochronous.
- Lubrication:** Forced Circulation.
- Air Cleaner:** Dry Type.
- Oil Reservoir:** 8.9 U.S. Qts. (8,5 Liters)
- Fuel Tank:** 52 U.S. Gallons (197 Liters).
- Full Load Operating Time:** 25.5 Hrs.
- Starter:** 12V Electric.

Engine Control Features: High Oil Temperature, Low Oil Level, High Oil Pressure (Behind Product Pistons) Safety Shut Down Switches/Indicators. Padlockable Box with Throttle Control, Tachometer, Coolant Temperature, Oil Pressure, Voltage and Overstart Indicators/Shutdowns. Manual/Stop Keyswitch. Fuel Level Display/Alarm/ Shutdown (For Use With Optional Fuel Level Sensor).

KOHLER PUBLISHED PERFORMANCE:
Maximum Gross Continuous Industrial B.H.P.
40 (30 kW) @ 2600 RPM



GORMAN-RUPP PUMPS

www.grpumps.com

Specifications Subject to Change Without Notice

Printed in U.S.A.

Specification Data

SECTION 46, PAGE 100

APPROXIMATE DIMENSIONS and WEIGHTS

WHEEL KIT
WEIGHT (FULL): 5,400 LBS. 2450 (KG)
SHIPPING WEIGHT: 5,070 LBS. 2300 (KG)
EXPORT CRATE SIZE: 565 CU. FT. [16,0 CU. M.]

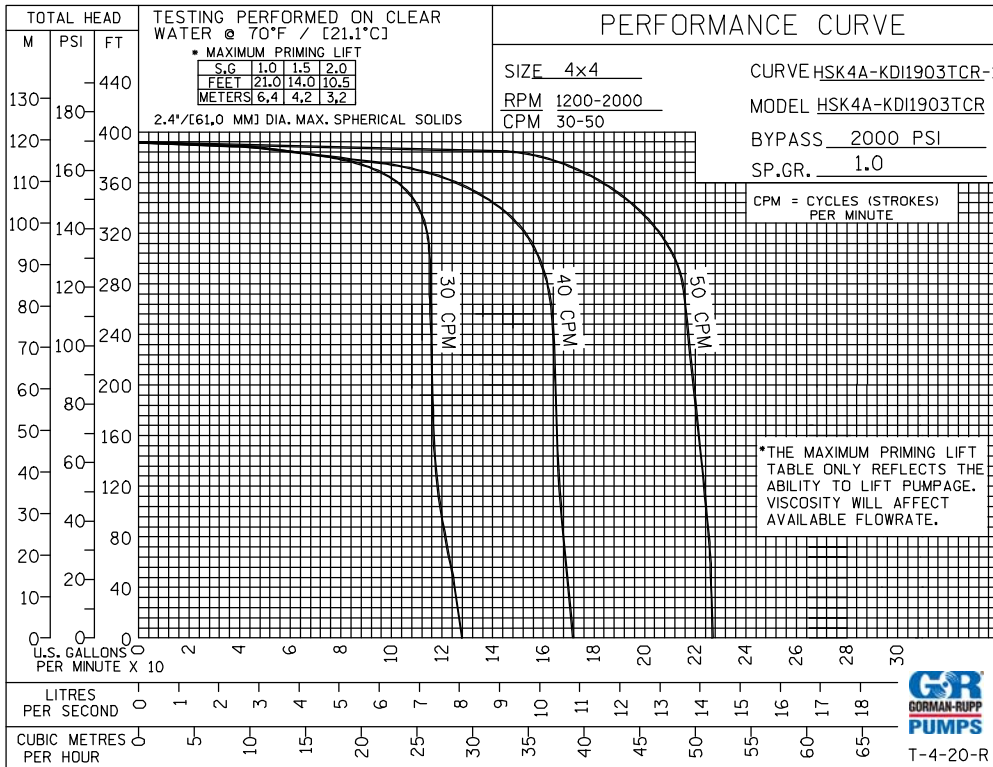
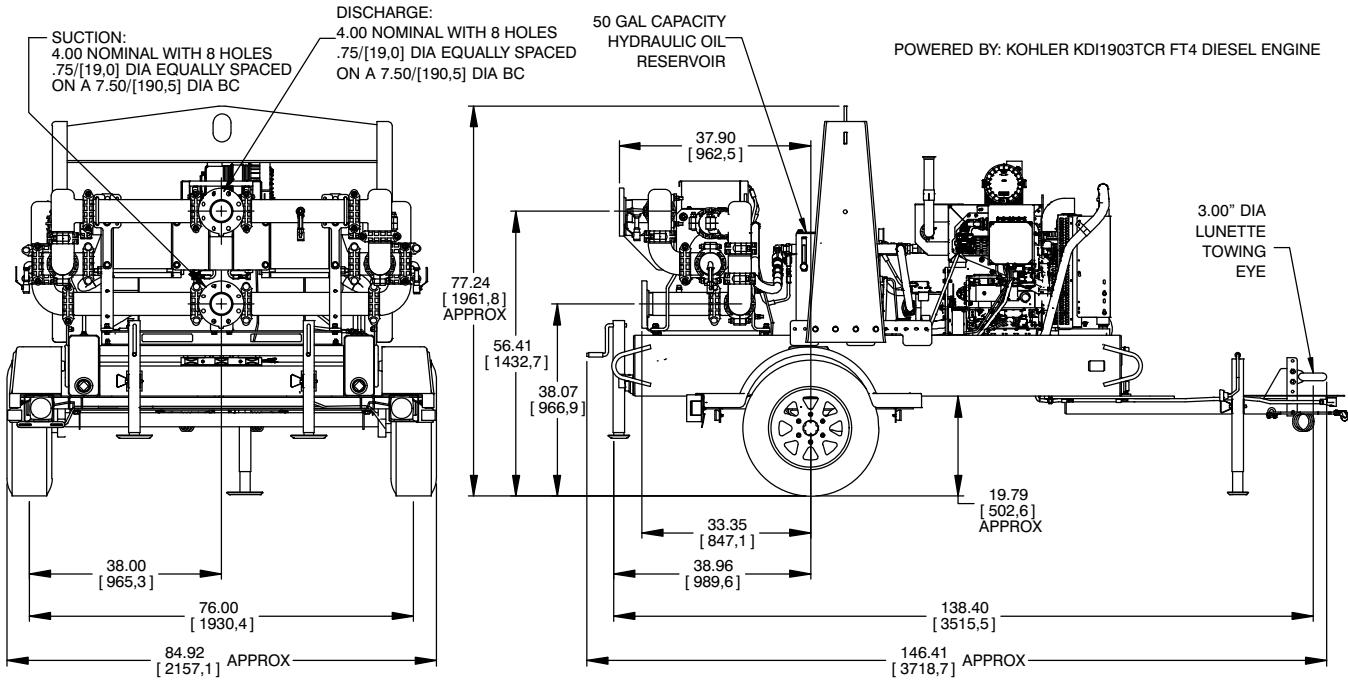

GORMAN-RUPP PUMPS

www.grpumps.com

Specifications Subject to Change Without Notice

Printed in U.S.A.