

NR, NRS

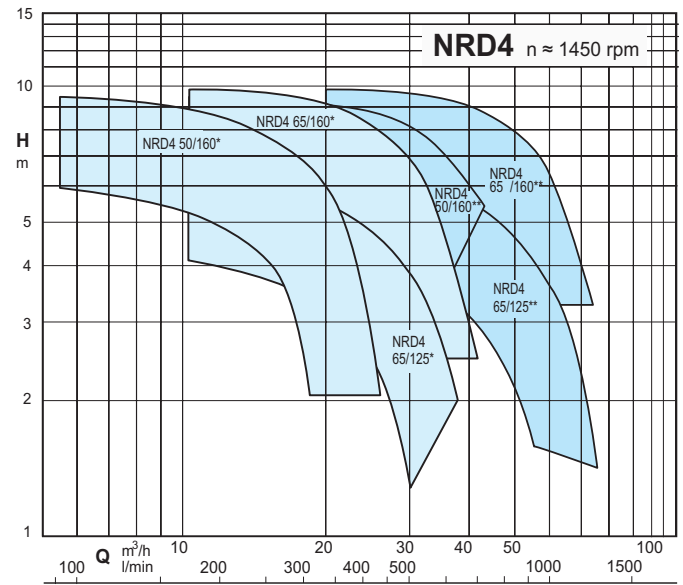

In-line pumps

Coverage chart

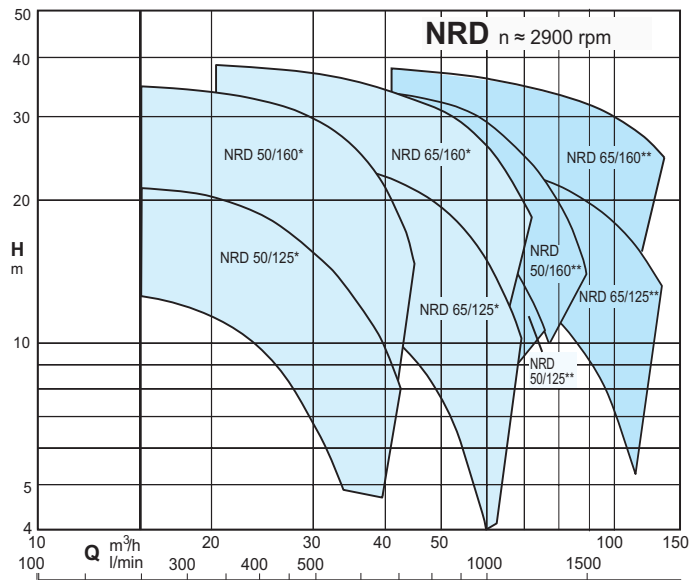
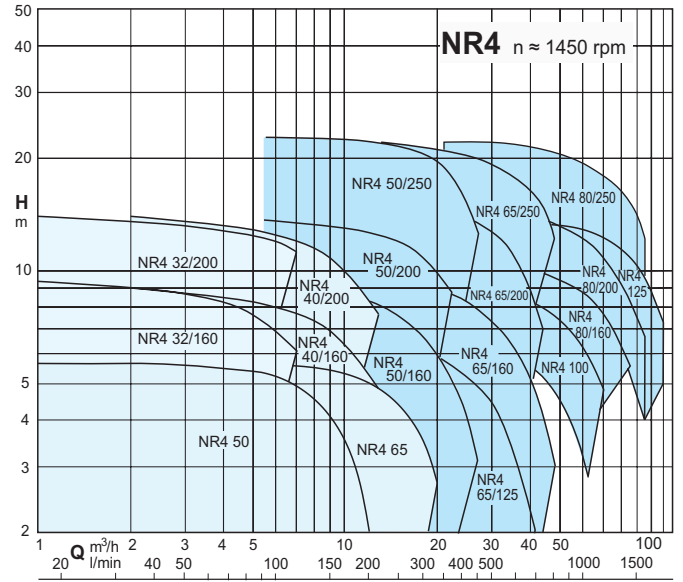
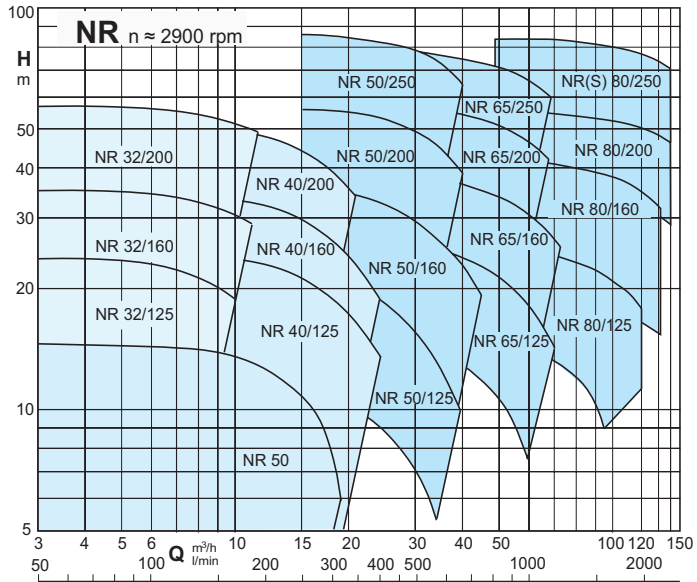

* Single operation
 ** Parallel operation

Construction

NR, NR4 Close-coupled, single-impeller, centrifugal pumps; electricmotor with extended shaft directly connected to the pump.

NRS Close-coupled centrifugal pumps, new bracket construction for standard motors (stub-shaft construction) with integrated thrust bearing.

NR, NR4 series: Single head electropumps.

NRD, NRD4: Twin head pump with built-in automatic switching valve. The two head can operate singularly or in parallel.

Pump casing with suction and delivery connections with the same diameter and on the same axis (in-line).

Connections: Flanges according to PN 10-16, EN 1092-2.

Counter-flanges on request.

Sizes	Flanges
NR, NR4 32,40,50,65,80 NRD, NRD4 50,65	Screwed flanges EN 1092-1, PN 16
NR 80 NR4 100, NR4 125	Flanges for welding EN 1092-1, PN 10 EN 1092-1, PN 10-16

Version with frequency converter (on request)

Applications

For clean liquids without abrasives, which are non-aggressive for the pump materials (solids content up to 0.2%).

For heating, air-conditioning, cooling and circulation plants.

For civil and industrial applications.

When low noise operation is required ($n \approx 1450$ rpm).

Operating conditions

Liquid temperature from -10 °C to $+90$ °C.

Ambient temperature up to 40 °C.

Total suction lift up to 7 m.

Maximum permissible working pressure up to 10 bar.

Continuous duty (S3 60% for single-phase pump to 1,5 kW).

Motor

2-pole induction motor, 50 Hz ($n \approx 2900$ rpm).

NR(D), NRS: three-phase 230/400 V $\pm 10\%$ up to 3 kW;

400/690 V $\pm 10\%$ from 4 to 37 kW;

NRM:single-phase 230 V $\pm 10\%$.

4-pole induction motor, 50 Hz ($n \approx 1450$ rpm).

NR4: three-phase 230/400 V $\pm 10\%$ up to 3 kW;

400/690 V $\pm 10\%$ from 4 to 5,5 kW.

Insulation class F.

Protection IP 54.

Motor suitable for operation with frequency converter from 0,37 kW for NR4 and from 1,1 kW for NR(D).

IE2 efficiency class for single-phase motors up to 1,1 kW.

IE3 efficiency class for three-phase motors (IE2 up to 0,65 kW).

Constructed in accordance with: EN 60034-1; EN 60034-30-1.

EN 60335-1, EN 60335-2-41.

Special features on request

Other voltages.

Impeller in chrome-nickel stainless steel AISI 316. (from NR. 40.. to NR. 80..)

Frequency 60 Hz (as per 60 Hz data sheet).

Protection IP 55.

Special mechanical seal

Higher or lower liquid or ambient temperatures.

Motor suitable for operation with frequency converter up to 0,33 kW for NR(D)4 and up to 0,75 kW for NR(D).

Designation

Example: NR(D)(S)(4)(M) EI 50/125A/A

NR = Series

D = Twin head

S = Series Version Stub-Shaft

4 = 4-pole version (without indication, 2-pole version)

M = Single-phase version (no indication: three-phase)

EI = With frequency converter I-MAT

50 = Delivery port diameter in mm

125 = Nominal impeller diameter

A = Impeller diameter

/A = It refers to a revision

The electropumps comply with the European Regulation no. 547/2012.

Materials

Components	Materials
Pump casing	Cast iron GJL 200 EN 1561
Lantern bracket	Cast iron GJL 200 EN 1561
Impeller	Cast iron GJL 200 EN 1561 (Brass CW617N EN 12165 for NR-NR4 32..., 40..., 50/200)
Shaft	Chrome-nickel steel 1.4305 EN 10088 (AISI 303)
	Steel 1.4104 EN 10088 AISI 430F (NR 32/12, NR, NR4 50)
Valve	Chrome-nickel steel AISI 304 - NBR
Mechanical seal	Carbon - Ceramic - NBR
Counter-flanges	Steel 1.0044 EN 10025-2 (Fe 430B)

EI: Pumps with frequency converter

The NR(D) EI, NR4 EI, pumps are available with power from 0,25 kW up to 22 kW, the pumps are equipped with I-MAT installed on board.

This design enables the creation of a highly compact and efficient variable-speed system, making them ideal for water supply applications and the distribution of hot and cold water.

The pump is fitted with transducers optimized for operation and is pre-programmed at the factory for seamless performance.

Features

- Energy saving
- Compact design
- Easy to use
- Programmable to suit the system requirements
- Reliability

Standard execution

- The system consists of:
 - Pump
 - Induction motor (2 for NRD, NRD4)
 - I-MAT Frequency converter (2 for NRD, NRD4)
 - Motor adapter for the motor mounting of the frequency converter (2 for NRD, NRD4)
 - Connection cable between frequency converter and induction motor
 - Single pressure transducer for 2 poles and differential transducer for 4 poles
 - - Communication cable for cascade mode for NRD, NRD4
 - - 2 Cascade mode expansion board for NRD, NRD4

Main features

Rated motor power output from 0,25 kW to 22 kW.

Control range from 1750 rpm (4-pole) to 2900 rpm (2-pole)

Control range from 870 to 1450 rpm (4-pole)

Protection against dry running

Protection against operations with closed valve ports

Protection against system leakages

Protection against overcurrent in the motor

Protection against overvoltage and undervoltage of the power supply

Protection against current unbalances between phases



Operating modes



Constant pressure mode

with pressure transducer

In this mode, the system maintains the preset pressure regardless of changes in the flow demand of the installation.

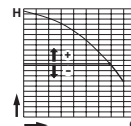

Proportional pressure mode

with pressure transducer

In this mode the system changes the working pressure according to the required flow rate.

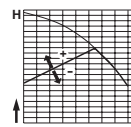

Constant flow mode

with flow meter

In this mode, the system maintains a constant flow rate at a specific point in the installation, adjusted according to the required pressure.

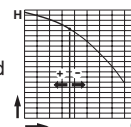

Fixed speed mode

with setting of the speed preferential rotation.

In this mode, by changing the working frequency, you may choose any operational curve included within the working range.

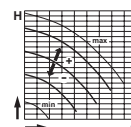

Constant temperature mode

with temperature transducer

In this mode the system keeps the temperature constant inside a system by changing the speed of the pump.

Coverage chart n ≈ 2900 rpm

Three-phase

Model	230V	400V	P2		Q = Flow														
					m³/h	0													
						l/min	6	6,6	7,5	8,4	9,6	10,8	12	13,2	15	16,8	18,9		
NR 50D/A	2,3	1,3	0,45	0,6	11,6	11	10,8	10,5	10,2	9,5	8,5	7	6	-	-	-			
NR 50C/B	3,7	2,2	0,75	1	16,2	16	15,9	15,8	15,7	15,3	14,6	14	13	11	9	5,5			

Single-phase

Model	230V	P2			P1	Q = Flow														
						m³/h	0													
							l/min	6	6,6	7,5	8,4	9,6	10,8	12	13,2	15	16,8	18,9		
NRM 50D/A	3,6	0,45	0,6	0,67	11,6	11	10,8	10,5	10,2	9,5	8,5	7	6	-	-	-				
NRM 50C/A	5,7	0,75	1	0	16,2	16	15,9	15,8	15,7	15,3	14,6	14	13	11	9	5,5				

Three-phase

Model	230V	400V	690V	P2		Q = Flow																
						m³/h	0															
							l/min	2,4	3	3,6	4,8	6	6,6	7,5	8,4	9,6	10,8	12	13,2	15	16,8	
NR 32/125B	3	1,7	-	0,55	0,75	18,3	18,4	18,3	18,1	17,5	16,7	16,3	15,7	15	-	-	-	-	-	-		
NR 32/125A	3,7	2,2	-	0,75	1	23,3	23,3	23,2	23,1	22,6	21,9	21,5	20,8	20,1	19,1	-	-	-	-	-		
NR 32/160B/A	4,6	2,7	-	1,1	1,5	28,1	27,9	27,6	27,3	26,5	25,6	25,1	24,3	23,4	21,9	20	-	-	-	-		
NR 32/160A/A	7,5	4,3	-	1,5	2	36,8	36,3	36,1	35,7	35	34,3	33,8	33,2	32,4	31,2	29,7	-	-	-	-		
NR 32/200B/A	9,2	5,3	-	2,2	3	42,5	-	41,6	41,3	40,6	39,8	39,3	38,5	37,7	36,5	35,1	33,4	-	-	-		
NR 32/200A	11,5	6,6	-	3	4	51,2	-	49,7	49,5	48,9	48,2	47,9	47,2	46,5	45,4	44,2	42,8	41,2	37,9	-		
NR 32/200S/A	-	9,6	5,5	4	5,5	58	-	57,4	57,2	56,7	56,1	55,8	55,1	54,4	53,3	52	50,5	48,8	45,9	42,6		

Single-phase

Model	230V	P2			P1	Q = Flow										
						m³/h	0									
							l/min	2,4	3	3,6	4,8	6	6,6	7,5	8,4	9,6
NRM 32/125B	4,2	0,55	0,75	0	18,3	18,4	18,3	18,1	17,5	16,7	16,3	15,7	15	-	-	
NRM 32/125A	5,4	0,75	1	0	23,3	23,3	23,2	23,1	22,6	21,9	21,5	20,8	20,1	19,1	-	
NRM 32/160B	7,4	1,1	1,5	1,6	38,2	27,9	27,6	27,3	26,5	25,6	25,1	24,3	23,4	21,9	20	
NRM 32/160A	9,2	1,5	2	2	36,8	36,3	36,1	35,7	35	34,3	33,8	33,2	32,4	31,2	29,7	

Three-phase

Model	230V	400V	690V	P2		Q = Flow																
						m³/h	0															
							l/min	6,6	7,5	8,4	9,6	10,8	12	13,2	15	16,8	18,9	21	24			
NR 40/125C	4	2,3	-	0,75	1	15,5	15,7	15,5	15,3	14,8	14,3	13,6	12,9	11,6	10,2	8,1	5,8	-				
NR 40/125B/A	4,6	2,7	-	1,1	1,5	19,5	19,8	19,6	19,4	19	18,5	18	17,5	16,5	15,2	13,6	11,6	8,5				
NR 40/125A/A	7,5	4,3	-	1,5	2	23,3	23,7	23,7	23,6	23,4	23,1	22,8	22,4	21,7	20,6	19,1	17,3	14,2				
NR 40/160B/A	7,5	4,3	-	1,5	2	26,1	25,7	25,4	25,1	24,6	24	23,3	22,6	21,4	19,7	17,3	14,4	9,9				
NR 40/160A/A	9,2	5,3	-	2,2	3	33,6	32,9	32,6	32,3	31,8	31,3	30,6	29,9	28,7	27,2	25,2	23,1	19,4				
NR 40/200B	11,5	6,6	-	3	4	41,9	40,2	39,7	39,2	38,5	37,6	36,7	35,7	33,8	31	26,9	22	-				
NR 40/200A/A	-	9,6	5,5	4	5,5	52,4	49,6	49,1	48,5	47,6	46,7	45,7	44,7	43	41,2	38,6	34,8	-				

Single-phase

Model	230V	P2			P1	Q = Flow											
						m³/h	0										
							l/min	6,6	7,5	8,4	9,6	10,8	12	13,2	15	16,8	18,9
NRM 40/125C	5,8	0,75	1	1,01	15,5	15,7	15,5	15,3	14,8	14,3	13,6	12,9	11,6	10,2	8,1	5,8	-
NRM 40/125B	7,4	1,1	1,5	1,44	19,5	19,8	19,6	19,4	19	18,5	18	17,5	16,5	15,2	13,6	11,6	8,5
NRM 40/125A	9,2	1,5	2	2	23,3	23,7	23,7	23,6	23,4	23,1	22,8	22,4	21,7	20,6	19,1	17,3	14,2
NRM 40/160B	9,2	1,5	2	2	26,1	25,7	25,4	25,1	24,6	24	23,3	22,6	21,4	19,7	17,3	14,4	9,9

Coverage chart n ≈ 2900 rpm

Three-phase

Model						Q = Flow													
						m³/h	0												
						l/min	15	16,8	18,9	21	24	27	30	33	37,8	39	42	45	
230V	400V	690V	P2			250	280	315	350	400	450	500	550	630	650	700	750		
A			kW	HP	H (m) = Total head														
NR 50/125F/A	4,6	2,7	-	1,1	1,5	14,9	13,8	13,4	12,8	12,1	11	9,9	8,4	6,9	-	-	-	-	
NR 50/125C/A	7,5	4,3	-	1,5	2	17,7	17,4	17	16,5	16	15	13,9	12,6	11,3	9	8,3	-	-	
NR 50/125A/B	9,2	5,3	-	2,2	3	22,2	21,7	21,4	21	20,6	19,8	18,8	17,5	16,3	14,1	13,5	12	-	
NR 50/160C/B	9,2	5,3	-	2,2	3	23,1	21,9	21,4	20,6	19,9	18,6	17,3	15,6	13,8	10,8	10	-	-	
NR 50/160B/A	11,5	6,6	-	3	4	28,6	27,9	27,4	26,7	26	24,6	23,1	21,3	19,7	16,6	15,7	13,6	-	
NR 50/160A/B	-	9,6	5,5	4	5,5	36,6	35,5	35,1	34,5	33,7	32,7	31,2	29,4	27,5	24,3	23,4	21,3	19,1	
NR 50/200D/B	-	9,6	5,5	4	5,5	41,8	37,8	36,8	35,7	34,5	32,4	30,1	27,6	24,9	-	-	-	-	
NR 50/200B/A	-	10,8	6,2	5,5	7,5	50,9	48,5	47,7	46,8	45,7	43,9	41,7	39,2	36,5	-	-	-	-	
NR 50/200A/A	-	14,3	8,3	7,5	10	56,7	54,9	54,3	53,4	52,4	50,7	48,9	46,5	44,1	39,7	38,8	-	-	
NR 50/250C/B	-	18,5	10,7	9,2	12,5	61,2	58,8	58	57,3	56,5	55	53,2	51,1	48,9	44,8	43,1	39,4	-	
NR 50/250B/A	-	21,5	12,4	11	15	69,4	67	66,4	65,5	64,8	63,2	61,5	59,6	57,7	53,8	52,6	50	-	
NR 50/250A/B	-	27,3	15,8	15	20	87	84,6	84,1	83,2	82,3	80,7	78,8	76,9	74,3	69,8	68,4	65,2	-	

Single-phase

Model					Q = Flow										
					m³/h	0									
					l/min	15	16,8	18,9	21	24	27	30	33	37,8	39
230V	P2		P1		250	280	315	350	400	450	500	550	630	650	
A	kW	HP	kW	H (m) = Total head											
NRM 50/125F	7,4	1,1	1,5	1,6	14,9	13,8	13,4	12,8	12,1	11	9,9	8,4	6,9	-	-
NRM 50/125C	9,2	1,5	2	2	17,7	17,4	17	16,5	16	15	13,9	12,6	11,3	9	8,3

Three-phase

Model						Q = Flow													
						m³/h	0												
						l/min	21	24	27	30	33	37,8	42	48	54	60	66	69	72
230V	400V	690V	P2			350	400	450	500	550	630	700	800	900	1000	1100	1150	1200	
A			kW	HP	H (m) = Total head														
NR 65/125F/B	9,2	5,3	-	2,2	3	16,5	16	15,7	15,3	14,8	14,3	13,5	12,5	11,1	9,5	7,3	5,3	-	-
NR 65/125D/A	11,5	6,6	-	3	4	21,1	20,2	19,9	19,6	19,2	18,7	17,9	16,9	15,2	13,3	11,3	9,1	-	-
NR 65/125A/B	-	9,6	5,5	4	5,5	25	24,4	24,1	23,8	23,4	23	22,2	21,4	19,8	18	15,9	13,7	12,4	-
NR 65/125S/B	-	9,6	5,5	4	5,5	27,2	26,3	26	25,7	25,4	25	24,3	23,6	22,1	20,3	18,3	16,1	14,7	-
NR 65/160B/A	-	10,8	6,2	5,5	7,5	31,9	32	31,7	31,4	30,9	30,4	29,5	28,6	26,8	24,8	22,2	19,7	18,3	16,7
NR 65/160A/A	-	14,3	8,3	7,5	10	39	39,3	39	38,7	38,3	37,9	36,9	36,1	34,7	32,9	30,6	28,1	26,7	25,3
NR 65/200B/B	-	18,5	10,7	9,2	12,5	47,1	46,7	45,9	45,1	44,4	43,6	42	40,5	37,9	35,3	32,4	28,3	-	-
NR 65/200A/A	-	21,5	12,4	11	15	54,2	53,3	52,8	52,3	51,5	50,7	49,2	47,5	45,1	41,9	38,1	34,5	-	-
NR 65/200S/B	-	27,3	15,8	15	20	60,4	60,5	60,2	59,6	59	58	56,3	54,5	52,2	49,5	46,5	42,7	-	-
NR 65/250C/A	-	21,5	12,4	11	15	54,6	54,8	54,2	53,5	52,8	52	50,5	48,9	46,3	43,5	40,6	37,3	-	-
NR 65/250B/B	-	27,3	15,8	15	20	67,1	67,2	66,7	66	65,1	64,3	62,8	61,3	58,6	55,8	52,9	49,7	-	-
NR 65/250A/C	-	34	19,6	18,5	25	78,5	78,5	77,8	77,3	76,7	76	74,8	73,6	71,1	68,4	65,5	62,2	-	-

P1: Maximum power input.

P2: Rated motor power output.

Tolerances according to UNI EN ISO 9906:2012

Coverage chart n ≈ 2900 rpm

Three-phase

Model					Q = Flow																
					m³/h	0	37,8	42	48	54	60	66	75	84	96	108	120	132	141		
					l/min	630	700	800	900	1000	1100	1250	1400	1600	1800	2000	2200	2350			
					H (m) = Total head																
400V		690V		P2																	
A		kW		HP																	
NR 80/125E	9,6	5,5	4	5,5	18,9	16,8	16,5	16,1	15,7	15,3	14,8	14	13,1	11,5	9,2	-	-	-			
NR 80/125C	10,8	6,2	5,5	7,5	21,6	20,5	20,3	20	19,7	19,3	18,9	18,3	17,4	15,9	13,9	11	-	-			
NR 80/125A	14,3	8,3	7,5	10	27	25,8	25,7	25,5	25,3	25	24,8	24,2	23,4	22,1	20,2	17,7	-	-			
NR 80/160D	14,3	8,3	7,5	10	25,2	-	-	24,8	24,5	24,1	23,8	23,3	22,6	21,3	19,1	16,1	-	-			
NR 80/160C	18,5	10,7	9,2	12,5	28,1	-	-	28,2	28,1	27,9	27,7	27,3	26,6	25,3	23,2	20,5	17	-			
NR 80/160B	21,5	12,5	11	15	32,4	-	-	32,8	32,7	32,5	32,2	31,8	31,1	29,9	28	25,5	22,4	-			
NR 80/160AR	27,7	16	15	20	36,2	-	-	36,7	36,5	36,3	36	35,7	35,3	34,5	32,9	30,5	27,8	-			
NR 80/160A	27,7	16	15	20	40,3	-	-	41,4	41,2	40,9	40,7	40,3	39,9	39,1	37,8	35,7	33,1	-			
NR 80/200C	27,7	16	15	20	41,1	-	-	42,8	42,7	42,5	42,2	41,5	40,5	38,7	36,4	33,7	30,7	28,2			
NR 80/200B	34	19,6	18,5	25	47,6	-	-	48,9	48,8	48,6	48,3	47,7	46,8	45,1	43	40,5	37,6	35,2			
NR 80/200A	41	23,7	22	30	55,2	-	-	56,7	56,7	56,6	56,5	56,1	55,5	54,3	52,6	50,4	47,7	45,4			
NR 80/250C	41	23,7	22	30	53,8	-	-	55,4	55,2	54,9	54,5	53,7	52,7	51	48,5	45	40,6	36,9			
NRS 80/250B	-	-	30	40	66,6	-	-	70,6	70,7	70,7	70,4	69,8	68,7	66,8	64,3	61,3	58	55,2			
NRS 80/250A	-	-	37	50	78,9	-	-	83,9	84,1	84,1	84	83,5	82,7	81	78,8	76,2	73,4	71,5			

P1: Maximum power input.

P2: Rated motor power output.

Tolerances according to UNI EN ISO 9906:2012

Rated current

Motor	IE3			IE4		
	400V	690V		400V	690V	
kW	A	A	la/In:	A	A	la/In:
30	53	30.5	8.6	51.5	29.9	9
37	65	37.5	7.1	63.3	36.7	9

A*: Calpeda motor Standard

la/In D.O.L. starting current / Nominal current

Performance n ≈ 1450 rpm

Three-phase

					Q = Flow											
					m³/h	0	2	4	6	8	10	12	14	16	18	20
Model	230V	400V	P2		l/min	0	33,3	66,6	100	133	167	200	233	267	300	333
	A		kW	HP	H (m) = Total head											
NR4 50C/A	1,3	0,75	0,25	0,34		3,9	3,9	3,8	3,3	2,5	-	-	-	-	-	-
NR4 50B/A	1,3	0,75	0,25	0,34		4,7	4,7	4,6	4,3	3,5	2,3	-	-	-	-	-
NR4 50A/A	1,3	0,75	0,25	0,34		5,6	5,6	5,5	5,2	4,5	3,5	2	-	-	-	-
NR4 65C/A	1,3	0,75	0,25	0,34		3,8	-	-	3,8	3,7	3,5	3,1	2,6	1,9	-	-
NR4 65B/A	2,1	1,2	0,33	0,45		4,7	-	-	4,7	4,6	4,5	4,2	3,8	3,2	2,5	-
NR4 65A/A	2,1	1,2	0,33	0,45		5,6	-	-	5,6	5,5	5,3	5	4,6	4,1	3,5	2,7

Single-phase

					Q = Flow									
					m³/h	0	2	4	6	8	10	12	14	16
Model	230V	P2		P1	l/min	0	33,3	66,6	100	133	167	200	233	267
	A	kW	HP	kW	H (m) = Total head									
NR4M 50C/A	2,1	0,25	0,34	0,27		3,9	3,9	3,8	3,3	2,5	-	-	-	-
NR4M 50B/A	2,1	0,25	0,34	0,29		4,7	4,7	4,6	4,3	3,5	2,3	-	-	-
NR4M 50A/A	2,1	0,25	0,34	0,33		5,6	5,6	5,5	5,2	4,5	3,5	2	-	-
NR4M 65C/A	2,1	0,25	0,34	0,31		3,8	-	-	3,8	3,7	3,5	3,1	2,6	1,9

Three-phase

					Q = Flow																	
					m³/h	0	1	1,2	1,5	1,89	2,4	3	3,6	4,2	4,8	5,4	6	6,6	7,5	8,4	9,6	
Model	230V	400V	P2		l/min	0	16,6	20	25	31,5	40	50	60	70	80	90	100	110	125	140	160	
	A		kW	HP	H (m) = Total head																	
NR4 32/160B/A	1,65	0,95	0,37	0,5		8,1	7,9	7,9	7,7	7,6	7,4	7,2	6,9	6,6	6,1	5,6	4,4	-	-	-	-	
NR4 32/160A/A	1,65	0,95	0,37	0,5		9,2	9,3	9,3	9,2	9,1	9	8,8	8,6	8,3	8	7,6	7,2	6,6	5,6	-	-	
NR4 32/200C/A	1,65	0,95	0,37	0,5		11,5	11,3	11,3	11,2	11,1	10,9	10,7	10,5	10,2	9,9	9,5	9,1	8,5	7,4	5,7	-	
NR4 32/200B/A	2,6	1,5	0,55	0,75		13,2	13,2	13,2	13,1	13	12,9	12,8	12,6	12,4	12,1	11,8	11,4	10,9	10	9,1	7,5	
NR4 32/200A/A	3,3	1,9	0,75	1		14,6	14,5	14,5	14,4	14,3	14,2	14,1	13,9	13,8	13,5	13,2	12,8	12,3	11,4	10,5	9,1	

Three-phase

					Q = Flow														
					m³/h	0	2,4	3	3,6	4,8	5,4	6	7,5	8,4	9,6	10,8	12	13,2	15
Model	230V	400V	P2		l/min	0	40	50	60	80	90	100	125	140	160	180	200	220	250
	A		kW	HP	H (m) = Total head														
NR4 40/160B/A	1,65	0,95	0,37	0,5		7,3	7,3	7,2	7,1	6,9	6,8	6,6	6,1	5,8	5,2	4,4	3,5	2,5	-
NR4 40/160A/A	1,65	0,95	0,37	0,5		9,1	9	9	9	8,8	8,7	8,6	8,1	7,8	7,2	6,5	5,7	4,8	3,3
NR4 40/200B/A	2,6	1,5	0,55	0,75		12,9	12,5	12,4	12,2	11,9	11,7	11,4	10,7	10,2	9,1	7,7	6,2	4,4	-
NR4 40/200A/A	3,3	1,9	0,75	1		14,7	14,3	14,2	14,1	13,9	13,7	13,5	12,9	12,4	11,6	10,5	9,2	7,7	4,9

Three-phase

					Q = Flow																
					m³/h	0	5,4	6	7,5	8,4	9,6	10,8	12	13,2	15	16,8	18,9	21	24	27	30
Model	230V	400V	P2		l/min	0	90	100	125	140	160	180	200	220	250	280	315	350	400	450	500
	A		kW	HP	H (m) = Total head																
NR4 50/160C/A	1,65	0,95	0,37	0,5		5,9	5,9	5,8	5,7	5,6	5,4	5,2	5	4,7	4,2	3,7	3,1	2,3	-	-	-
NR4 50/160B/A	2,6	1,5	0,55	0,75		7,3	7,4	7,4	7,2	7,1	6,9	6,7	6,4	6,2	5,7	5,2	4,5	3,8	2,5	-	-
NR4 50/160A/B	3,3	1,9	0,75	1		9,2	9,2	9,2	9,1	9	8,9	8,7	8,4	8,2	7,6	7,1	6,4	5,6	4,4	3,1	-
NR4 50/200B/B	5	2,9	1,1	1,5		12,8	12,6	12,5	12,3	12,1	11,9	11,5	11,2	10,7	10	9,2	8,2	7,1	5,2	-	-
NR4 50/200A/B	5	2,9	1,1	1,5		14,3	14,1	14	13,9	13,7	13,5	13,2	12,8	12,4	11,7	11	10	8,8	7,3	-	-
NR4 50/250C/B	6	3,5	1,5	2		17,1	17	16,9	16,6	16,4	16,1	15,9	15,6	15,2	14,6	13,9	12,8	11,3	8,5	5,3	-
NR4 50/250B/B	8,6	5	2,2	3		21	20,9	20,8	20,5	20,3	20	19,7	19,4	19	18,4	17,8	16,8	15,6	13,8	11,7	8,5
NR4 50/250A/A	11,1	6,4	3	4		22	21,9	21,9	21,8	21,6	21,4	21,1	20,9	20,5	19,9	19,2	18,3	17,2	15,3	13,4	11

P1: Maximum power input.

P2: Rated motor power output.

Tolerances according to UNI EN ISO 9906:2012

Performance n ≈ 1450 rpm

Three-phase

						Q = Flow														
						m³/h	0	10,8	12	13,2	15	16,8	18,9	21	24	27	30	33	42	48
Model	230V	400V	690V	P2		l/min	180	200	220	250	280	315	350	400	450	500	550	700	800	
	A			kW	HP	H (m) = Total head														
NR4 65/125F/A	1,65	0,95	-	0,37	0,5	4,1	3,9	3,8	3,8	3,6	3,5	3,3	3	2,6	2,1	1,6	1	-	-	
NR4 65/125D/A	2,6	1,5	-	0,55	0,75	5,3	5	5	4,9	4,8	4,7	4,5	4,3	3,9	3,4	2,9	2,4	-	-	
NR4 65/125A/B	3,3	1,9	-	0,75	1	6,3	6,2	6,1	6	5,9	5,8	5,7	5,5	5,1	4,6	4,1	3,5	1,5	-	
NR4 65/125S/B	3,3	1,9	-	0,75	1	6,8	6,6	6,6	6,5	6,4	6,3	6,1	5,9	5,6	5,1	4,6	4,1	2,1	-	
NR4 65/160B/B	5	2,9	-	1,1	1,5	8,2	8,2	8,2	8,1	8	7,9	7,7	7,5	7,1	6,6	6	5,4	3,2	-	
NR4 65/160A/B	5	2,9	-	1,1	1,5	9,7	9,6	9,5	9,5	9,4	9,2	9	8,8	8,5	8	7,4	6,8	4,7	3	
NR4 65/200C/B	5	2,9	-	1,1	1,5	11,4	11,3	11,2	11,1	10,8	10,6	10,3	9,9	9,4	8,7	7,9	7	3,4	-	
NR4 65/200B/B	6	3,5	-	1,5	2	13,3	13,1	13	12,9	12,7	12,4	12,1	11,8	11,2	10,5	9,7	8,9	5,4	-	
NR4 65/200A/B	8,6	5	-	2,2	3	14,5	14,6	14,5	14,4	14,2	13,9	13,6	13,2	12,7	12	11,3	10,5	7,2	-	
NR4 65/250D/B	8,6	5	-	2,2	3	13,7	13,9	13,8	13,8	13,6	13,4	13,1	12,8	12,3	11,6	10,9	10,1	7,2	-	
NR4 65/250C/B	8,6	5	-	2,2	3	17,1	17,3	17,2	17,2	16,9	16,7	16,3	16	15,4	14,7	13,9	13	10	-	
NR4 65/250B/A	11,1	6,4	-	3	4	19,9	20,1	20	20	19,8	19,6	19,3	19	18,4	17,7	16,9	16,1	13,2	10,8	
NR4 65/250A/A	-	8,3	4,8	4	5,5	21,4	21,6	21,5	21,4	21,3	21,1	20,8	20,5	19,9	19,2	18,4	17,6	14,7	12,2	

Three-phase

						Q = Flow														
						m³/h	0	21	24	27	30	33	37,8	42	48	54	60	66	75	84
Model	230V	400V	690V	P2		l/min	350	400	450	500	550	630	700	800	900	1000	1100	1250	1400	1600
	A			kW	HP	H (m) = Total head														
NR4 80/160C	5	2,9	-	1,1	1,5	6,7	6,3	6,2	6,1	-	6	5,8	5,7	5,4	4,8	4,1	-	-	-	-
NR4 80/160B	5	2,9	-	1,1	1,5	7,4	7,2	7,2	7,1	-	7	6,8	6,7	6,4	6	5,2	4,4	-	-	-
NR4 80/160A	6	3,5	-	1,5	2	8,8	8,7	8,7	8,7	-	8,6	8,5	8,4	8,1	7,7	7,1	6,4	5,2	-	-
NR4 80/160S	8,6	5	-	2,2	3	10,2	10,2	10,2	10,2	-	10,1	10	9,9	9,6	9,3	8,8	8,2	7	5,7	-
NR4 80/200B	8,6	5	-	2,2	3	11,4	11,7	11,7	11,7	-	11,6	11,4	11,3	10,9	10,4	9,8	9	7,8	6,3	3,8
NR4 80/200A	11,1	6,4	-	3	4	13,9	14,2	14,1	14,1	-	14	13,9	13,7	13,4	13	12,4	11,7	10,4	9	6,7
NR4 80/250B	-	8,3	4,8	4	5,5	16,3	17,4	17,4	17,4	17,4	17,3	17,1	16,8	16,4	15,7	14,9	14	12,4	10,4	7,4
NR4 80/250A	-	12,5	7,2	5,5	7,5	20,3	21,4	21,4	21,5	21,4	21,4	21,3	21,1	20,7	20,3	19,6	18,9	17,5	15,8	12,9

Three-phase

						Q = Flow														
						m³/h	0	20	25	30	35	40	50	60	70	80	90	100	110	
Model	230V	400V	690V	P2		l/min	333	417	500	583	667	833	1000	1167	1333	1500	1667	1833		
	A			kW	HP	H (m) = Total head														
NR4 100C/B	5	2,9	-	1,1	1,5	6,6	6,6	6,4	6,3	6	5,6	4,6	3,3	-	-	-	-	-	-	
NR4 100B/B	5	2,9	-	1,1	1,5	7,5	7,5	7,4	7,2	7	6,6	5,6	4,4	-	-	-	-	-	-	
NR4 100A/B	6	3,5	-	1,5	2	9	9	8,9	8,8	8,6	8,3	7,4	6,2	4,8	-	-	-	-	-	
NR4 125C/B	8,6	5	-	2,2	3	10,2	-	-	10,2	10,1	10	9,6	9	8,2	7,1	5,7	4	-	-	
NR4 125B/A	11,1	6,4	-	3	4	12	-	-	12	11,9	11,8	11,6	11	10,4	9,4	8,2	6,7	5,1	-	
NR4 125A/A	-	8,3	4,8	4	5,5	13,6	-	-	13,6	13,5	13,4	13,2	12,9	12,3	11,4	10,3	8,8	7,2	-	

P1: Maximum power input.

P2: Rated motor power output.

Tolerances according to UNI EN ISO 9906:2012

Coverage chart n ≈ 2900 rpm
Single operation
Three-phase

Model	230V	400V	690V	P2		Q = Flow													
						m³/h	0												
						l/min	15	16,8	18,9	21	24	27	30	33	37,8	39	42	45	
A		kW	HP	H (m) = Total head															
NRD 50/125F	4,6	2,7	-	1,1	1,5	13,7	13,2	12,7	12	11,2	9,9	8,5	6,8	4,8	-	-	-	-	
NRD 50/125C	7,5	4,3	-	1,5	2	17,8	17,8	17,4	16,8	16	14,8	13,3	11,7	9,9	6,8	5,9	-	-	
NRD 50/125A	9,2	5,3	-	2,2	3	20,8	21,2	20,9	20,5	19,9	18,7	17,4	15,8	14,1	11,1	10,4	8,3	-	
NRD 50/160C	9,2	5,3	-	2,2	3	23,4	22,9	22,4	21,7	20,9	19,4	17,7	15,7	13,4	9,1	7,8	-	-	
NRD 50/160B	11,5	6,6	-	3	4	25,6	25	24,6	24	23,3	22	20,4	18,5	16,2	11,9	10,7	7,5	-	
NRD 50/160A	-	9,6	5,5	4	5,5	34	34,6	34,3	33,8	33,2	32	30,5	28,7	26,7	22,8	21,7	18,8	15,6	

Three-phase

Model	230V	400V	690V	P2		Q = Flow													
						m³/h	0												
						l/min	21	24	27	30	33	37,8	42	48	54	60	66	69	72
A		kW	HP	H (m) = Total head															
NRD 65/125F	9,2	5,3	-	2,2	3	16,2	14,9	14,4	13,8	13,2	12,5	11,3	10,1	8,2	6,1	3,9	-	-	-
NRD 65/125D	11,5	6,6	-	3	4	20,4	19,1	18,6	18,1	17,5	16,9	15,7	14,4	12,4	10	7,2	4,3	-	-
NRD 65/125A	-	9,6	5,5	4	5,5	25,3	25	24,7	24,3	23,8	23,2	22,1	21	19,1	16,9	14,3	11,5	9,9	-
NRD 65/160B	-	10,8	6,2	5,5	7,5	30,7	31,3	31,1	30,8	30,4	29,9	28,6	27,2	24,7	21,7	18,2	14,5	12,5	10,4
NRD 65/160A	-	14,3	8,3	7,5	10	37,5	37,7	37,6	37,4	37,1	36,6	35,6	34,4	32,1	29,3	26	22,5	20,6	18,5

Parallel operation

For parallel operation see curve diagram

P1: Maximum power input.

P2: Rated motor power output.

Tolerances according to UNI EN ISO 9906:2012

Performance n ≈ 1450 rpm
Single operation
Three-phase

Model	230V	400V	P2		Q = Flow														
					m³/h	0													
					l/min	5,4	6	7,5	8,4	9,6	10,8	12	13,2	15	16,8	18,9	21	24	27
A		kW	HP	H (m) = Total head															
NRD4 50/160C	1,65	0,95	0,37	0,5	5,9	5,9	5,8	5,7	5,5	5,3	5,1	4,8	4,5	3,9	3,1	2,1	-	-	-
NRD4 50/160B	2,6	1,5	0,55	0,75	7,3	7,5	7,5	7,4	7,3	7,1	6,8	6,6	6,3	5,7	5,1	4,1	3	1,3	-
NRD4 50/160A	3,3	1,9	0,75	1	9,3	9,5	9,5	9,4	9,3	9,2	9,1	8,9	8,6	8,1	7,6	6,8	5,8	4,1	2,1

Three-phase

Model	230V	400V	P2		Q = Flow													
					m³/h	0												
					l/min	10,8	12	13,2	15	16,8	18,9	21	24	27	30	33	37,8	42
A		kW	HP	H (m) = Total head														
NRD4 65/125F	1,65	0,95	0,37	0,5	4,3	4,1	4	3,9	3,7	3,5	3,3	3	2,5	2	1,3	-	-	-
NRD4 65/125D	2,6	1,5	0,55	0,75	5,4	5,2	5,1	5	4,9	4,7	4,4	4,1	3,6	3,1	2,5	1,7	-	-
NRD4 65/125A	3,3	1,9	0,75	1	6,5	6,4	6,3	6,3	6,1	6	5,8	5,5	5	4,4	3,8	3,1	2	-
NRD4 65/160B	5	2,9	1,1	1,5	8,1	8,2	8,2	8,1	8	7,9	7,6	7,3	6,7	6	5,1	4,1	2,5	-
NRD4 65/160A	5	2,9	1,1	1,5	9,8	9,8	9,8	9,7	9,6	9,4	9,2	8,9	8,3	7,7	6,9	6	4,3	2,6

Parallel operation

For parallel operation see curve diagram

P1: Maximum power input.

P2: Rated motor power output.

Tolerances according to UNI EN ISO 9906:2012

Coverage chart $n \approx 2900$ rpm

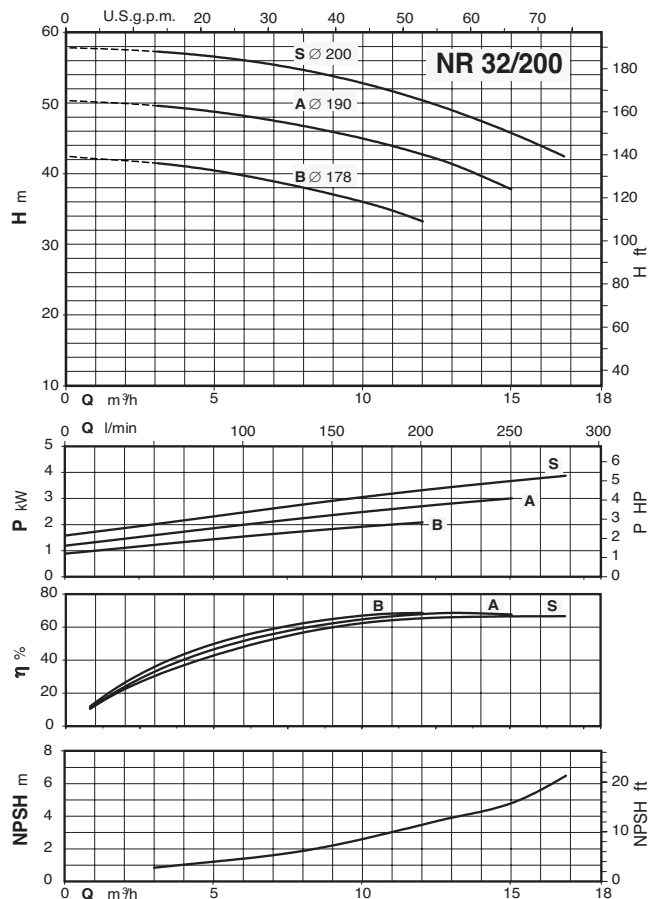
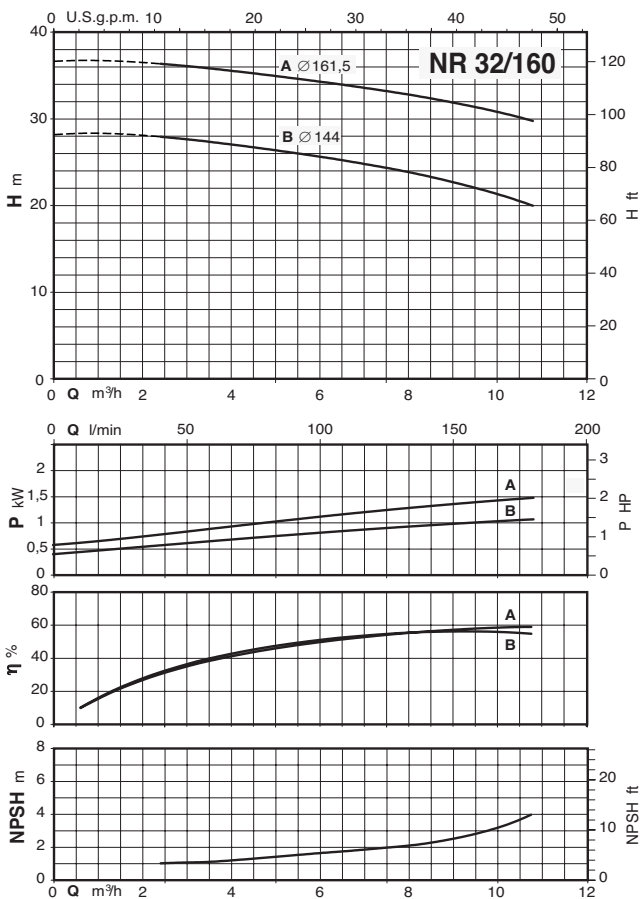
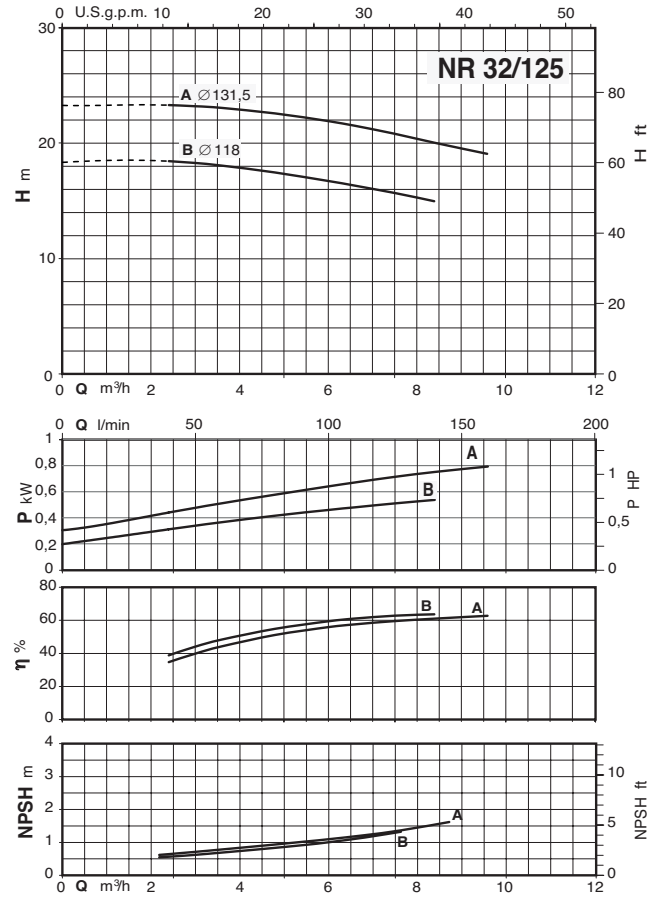
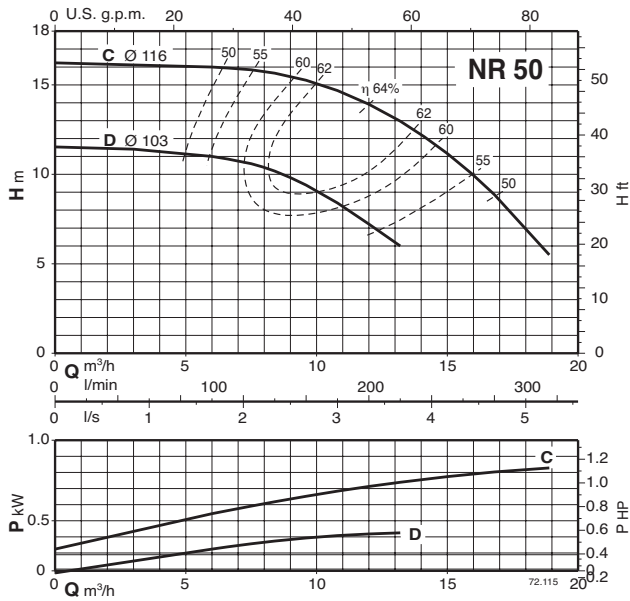

Coverage chart $n \approx 2900$ rpm

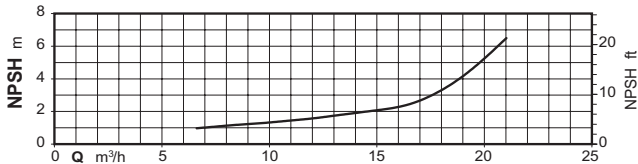
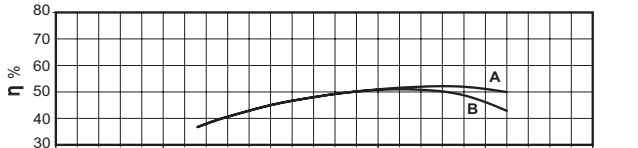
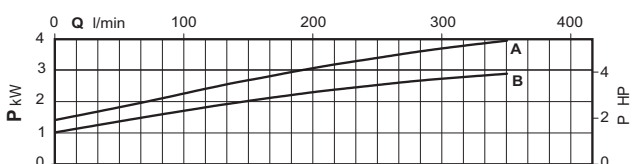
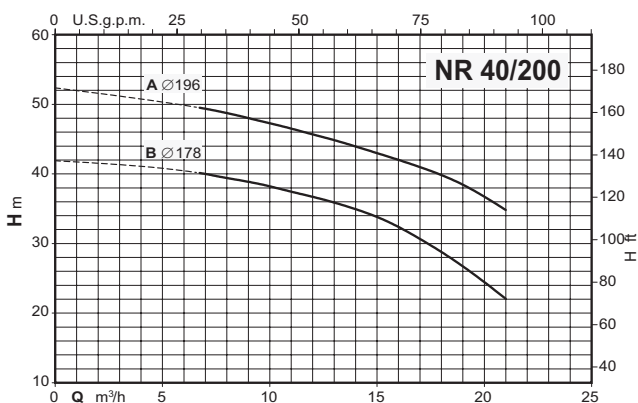
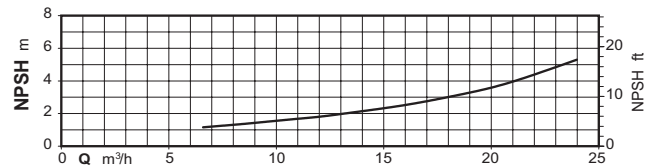
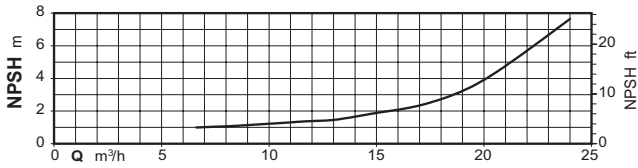
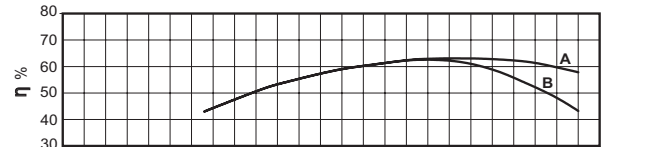
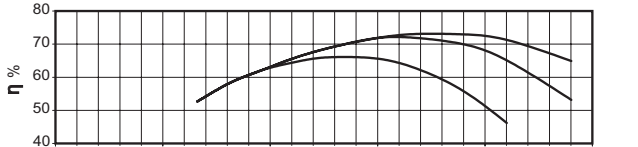
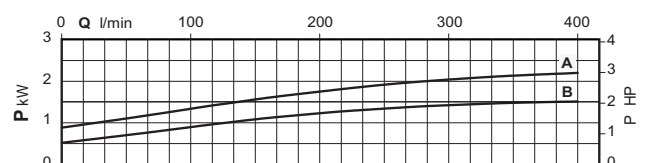
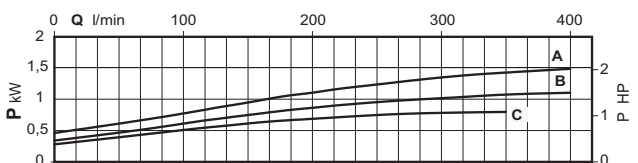
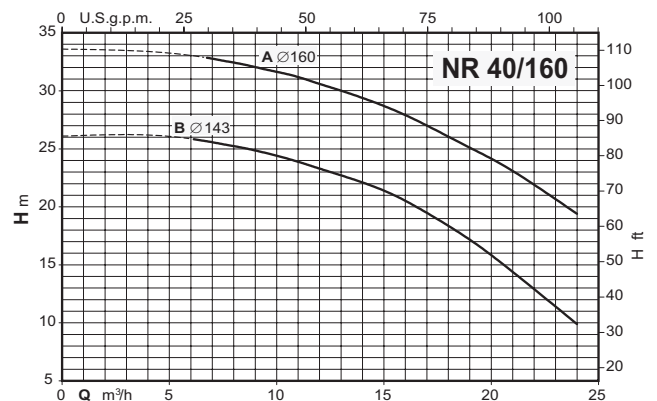
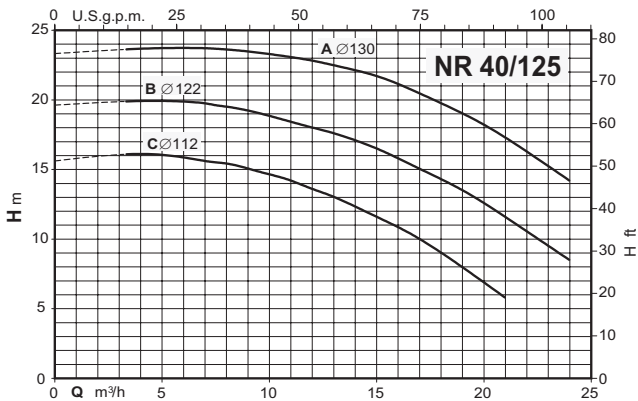

Coverage chart $n \approx 2900$ rpm

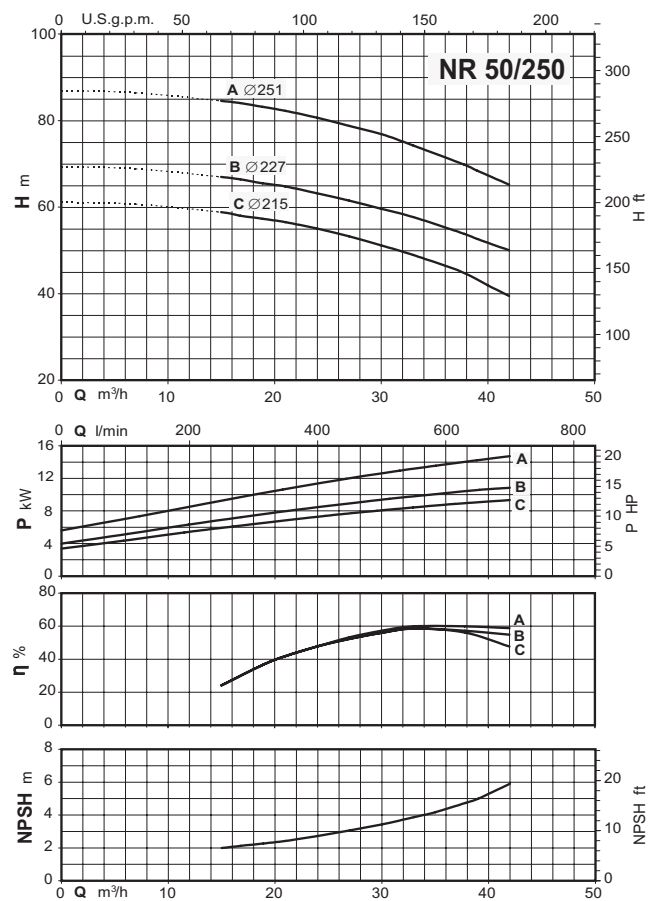
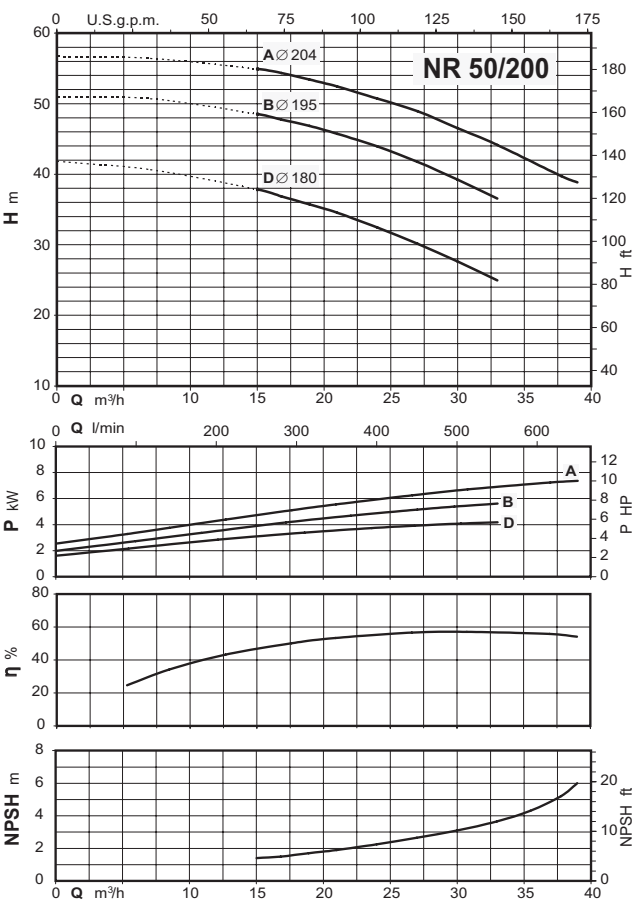
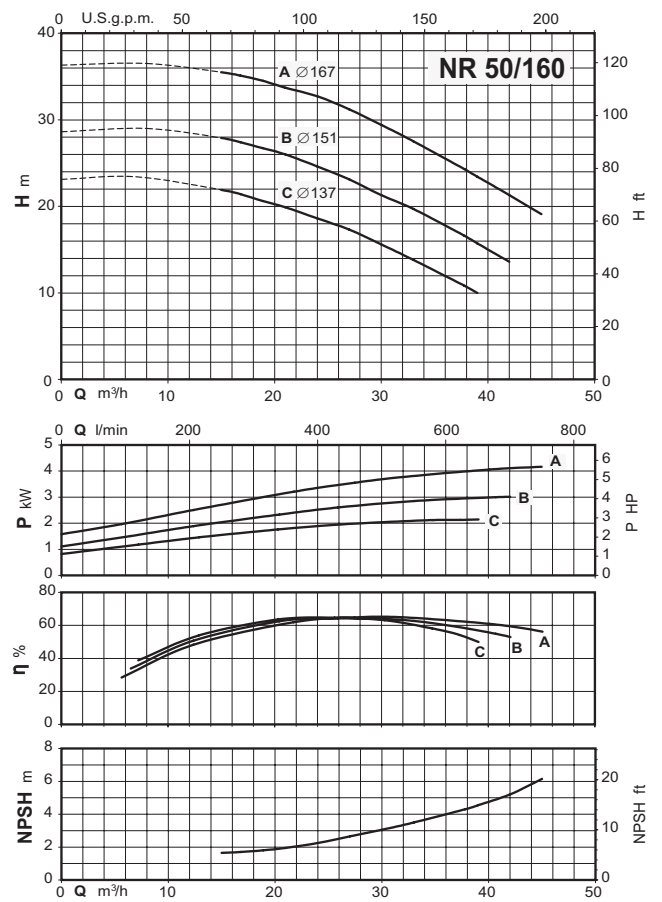
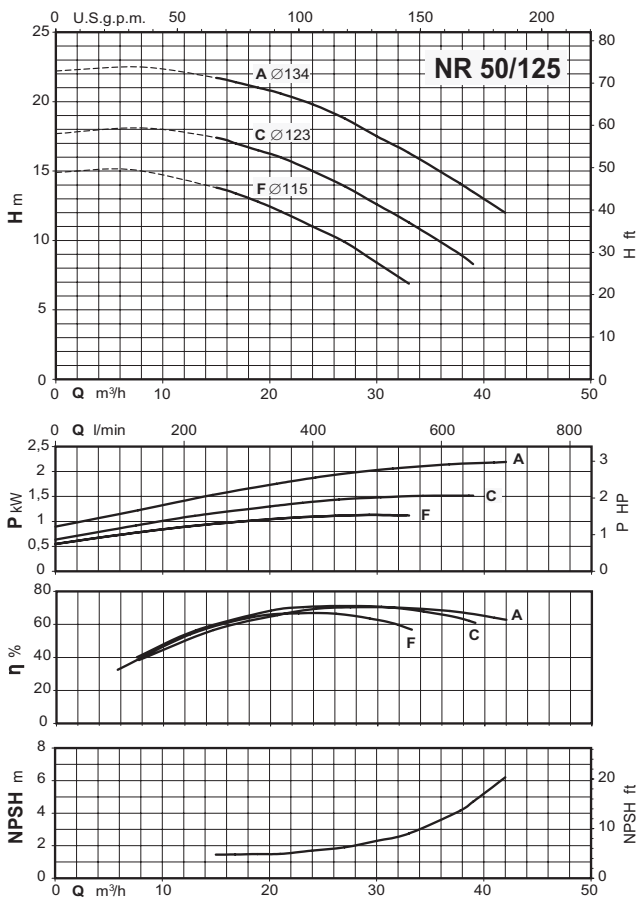

Coverage chart $n \approx 2900$ rpm

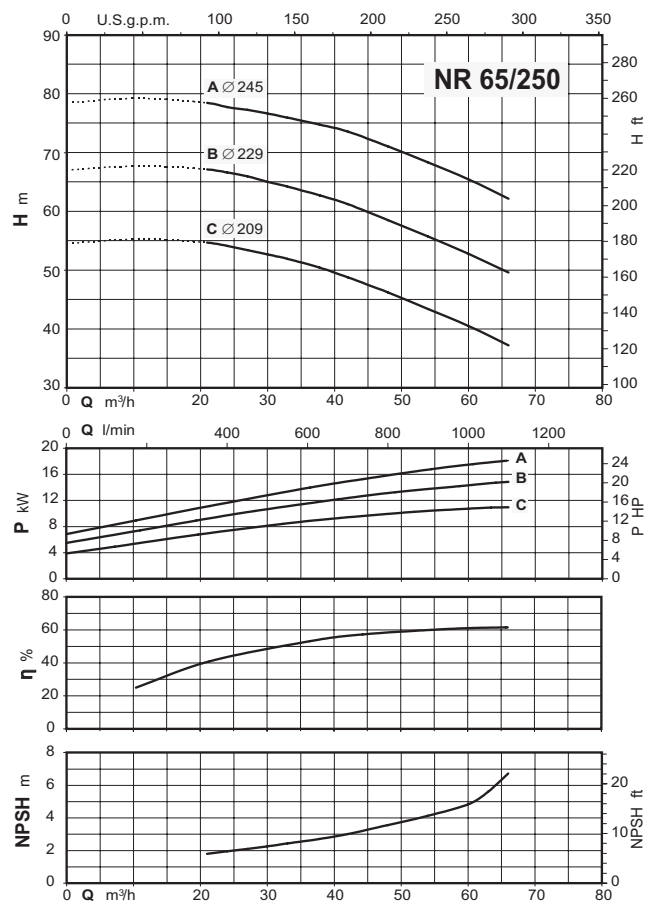
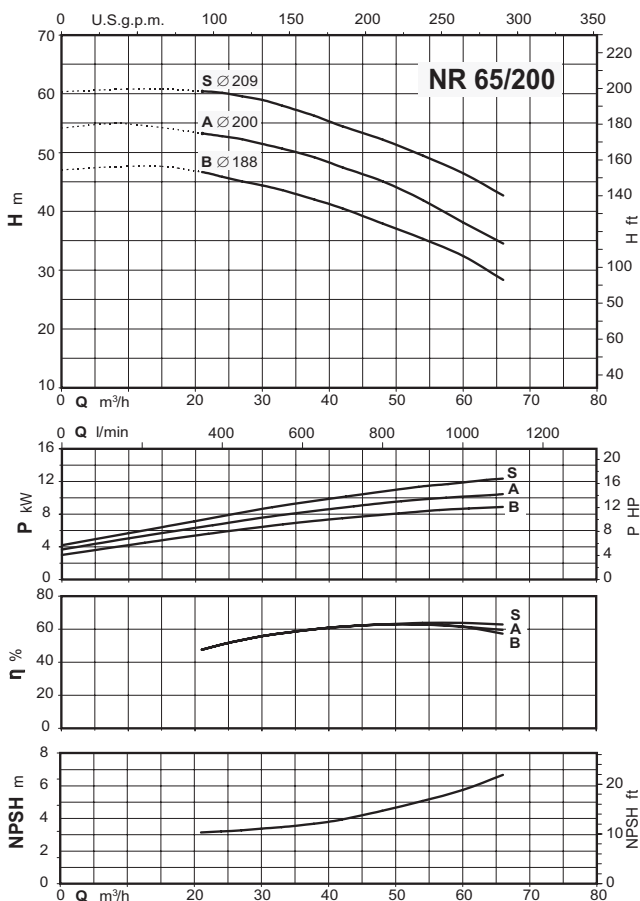
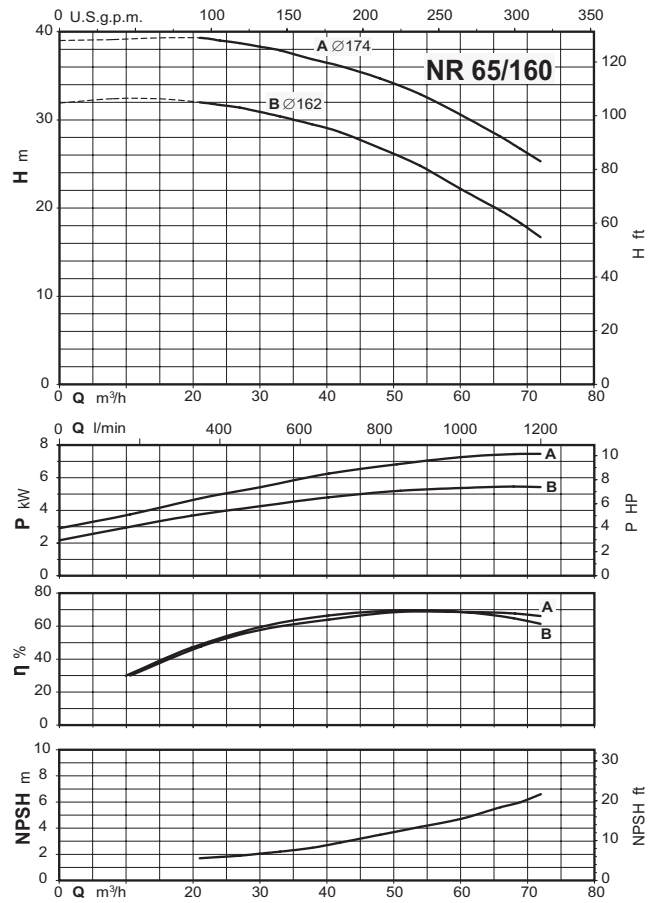
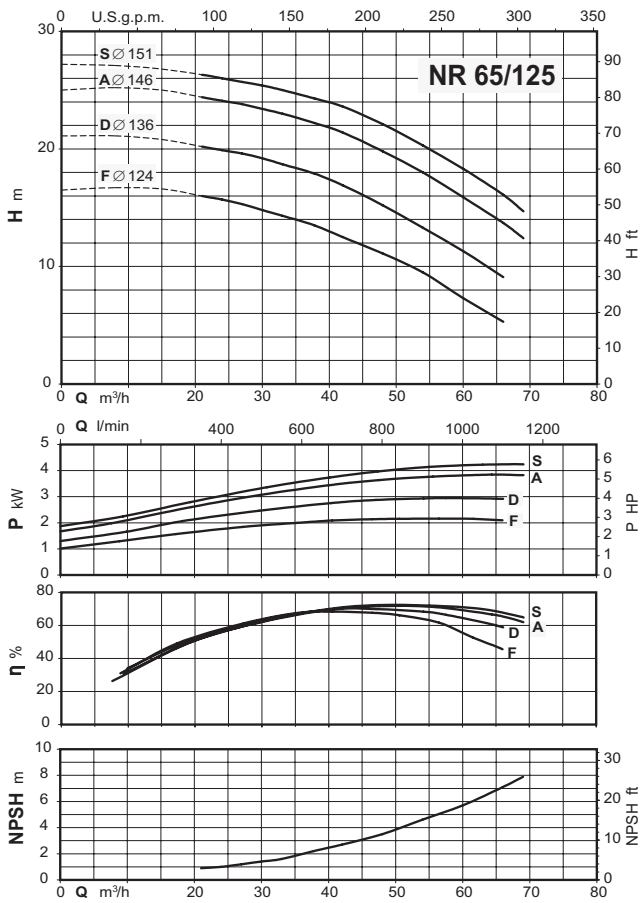

Coverage chart $n \approx 2900$ rpm

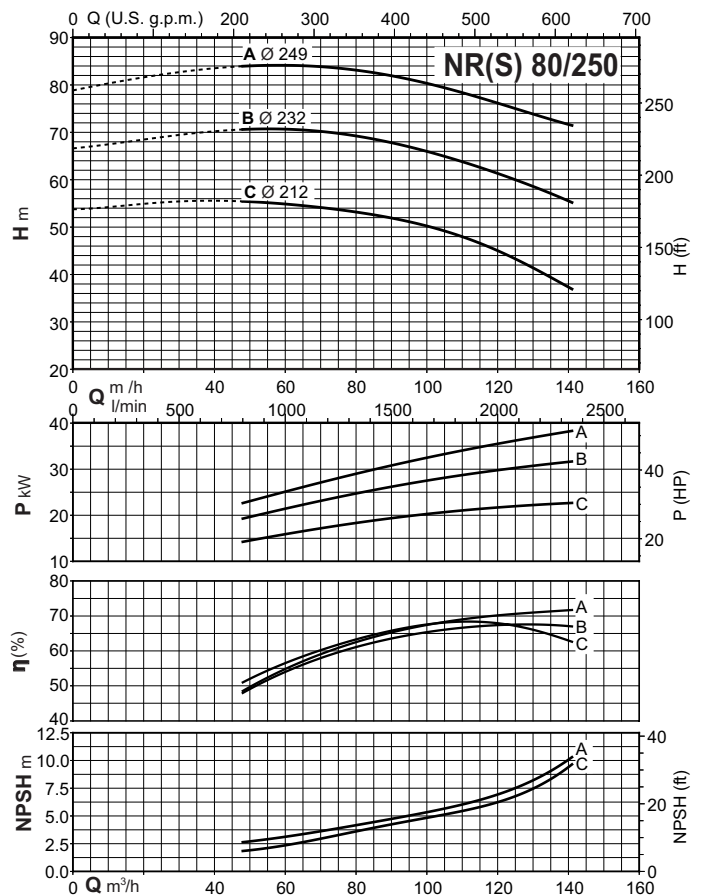
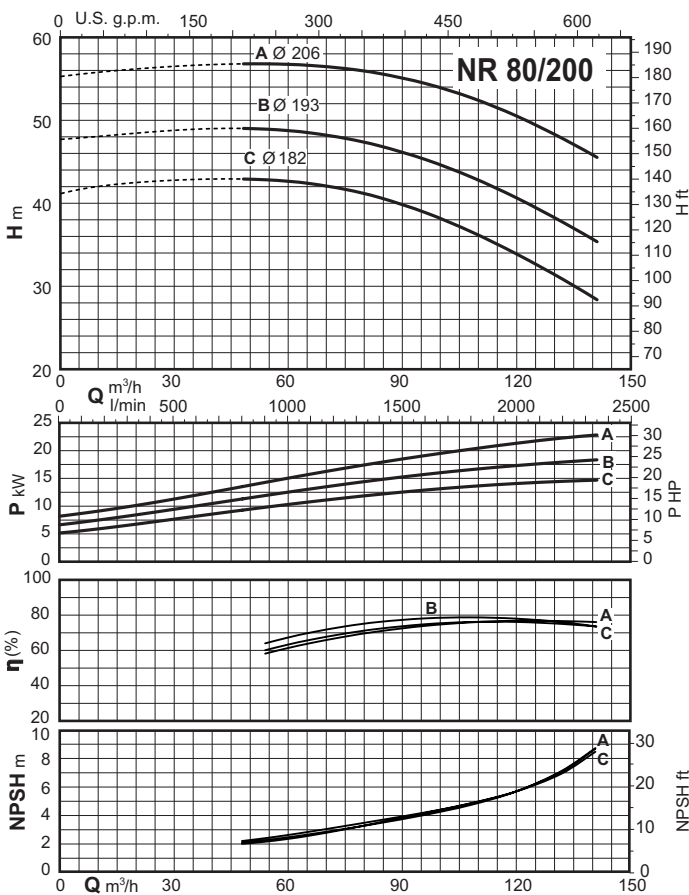
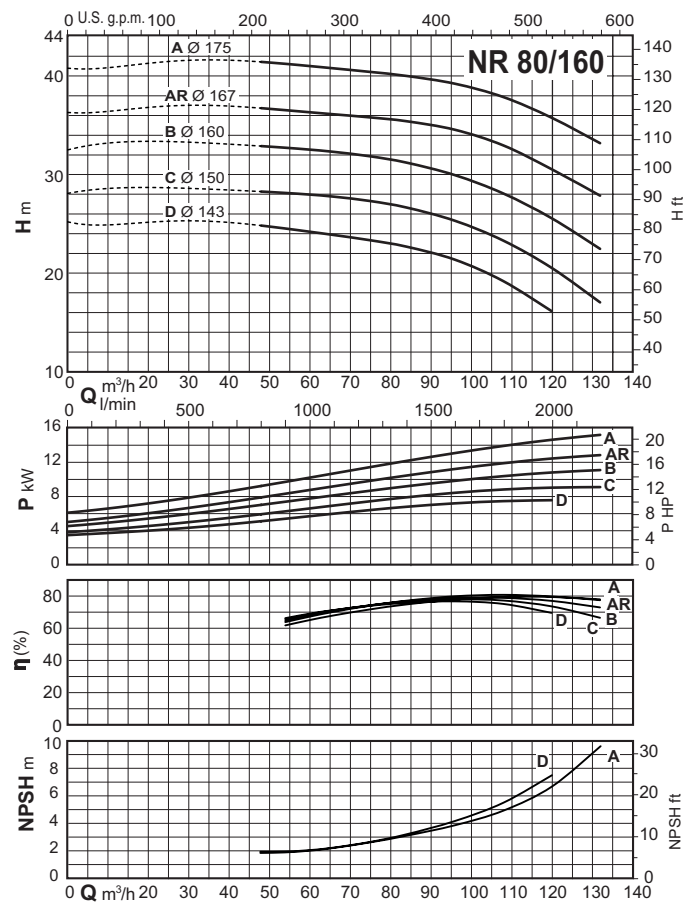
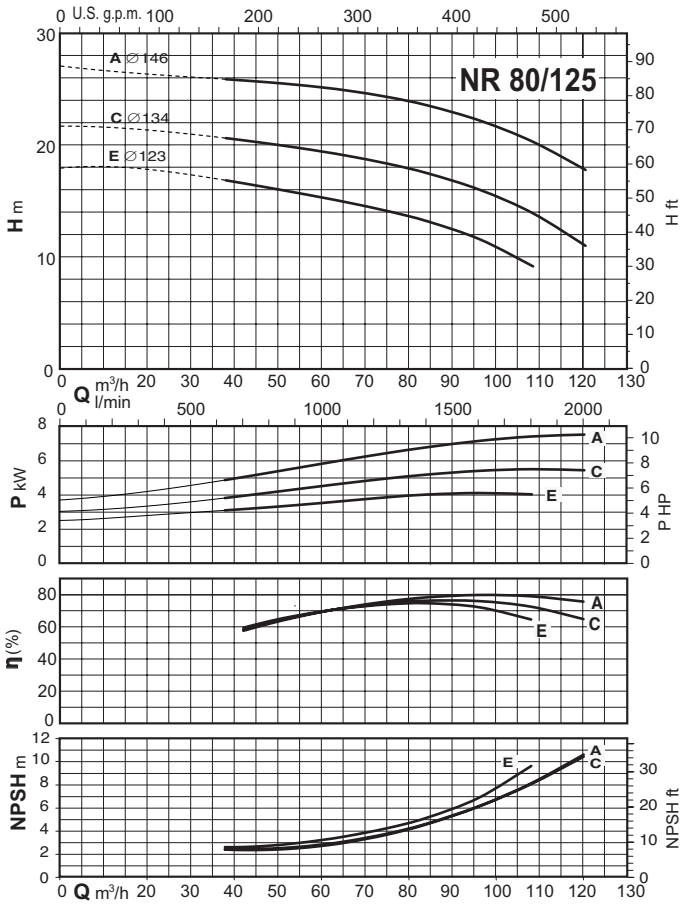

Coverage chart $n \approx 1450$ rpm

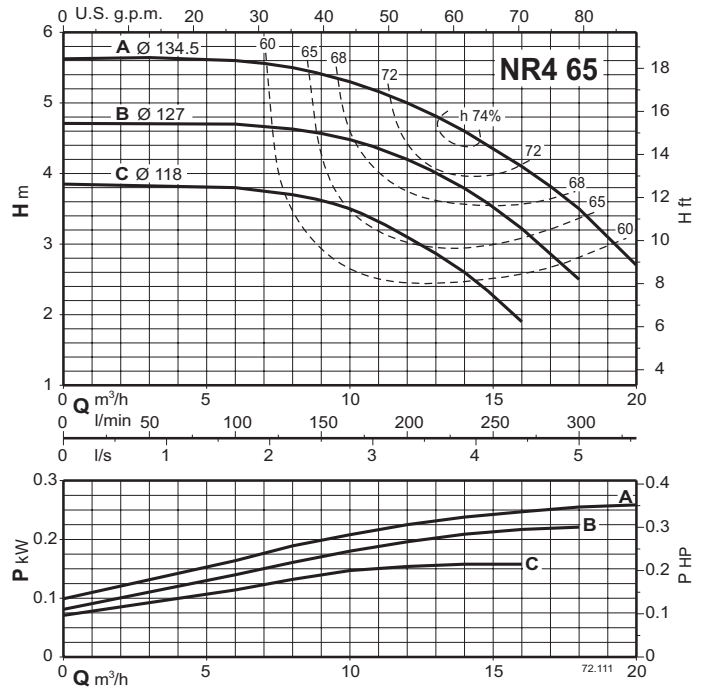
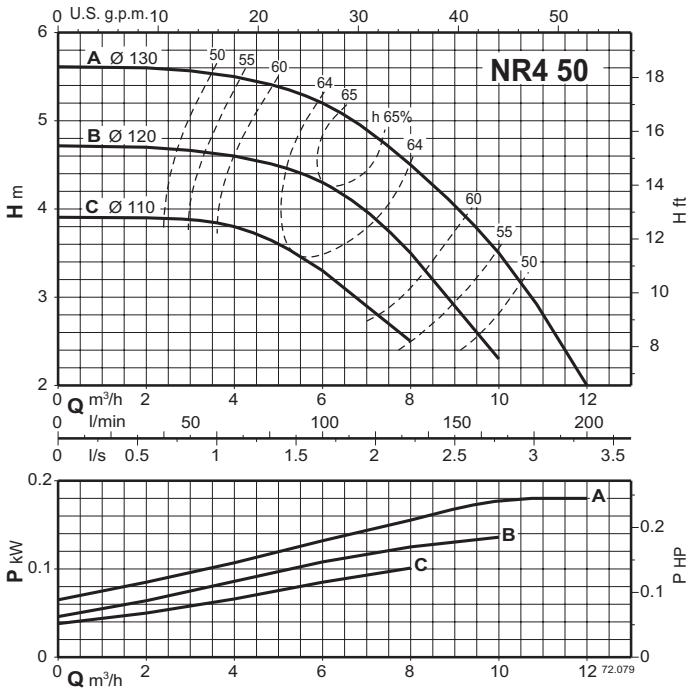

Coverage chart $n \approx 1450$ rpm

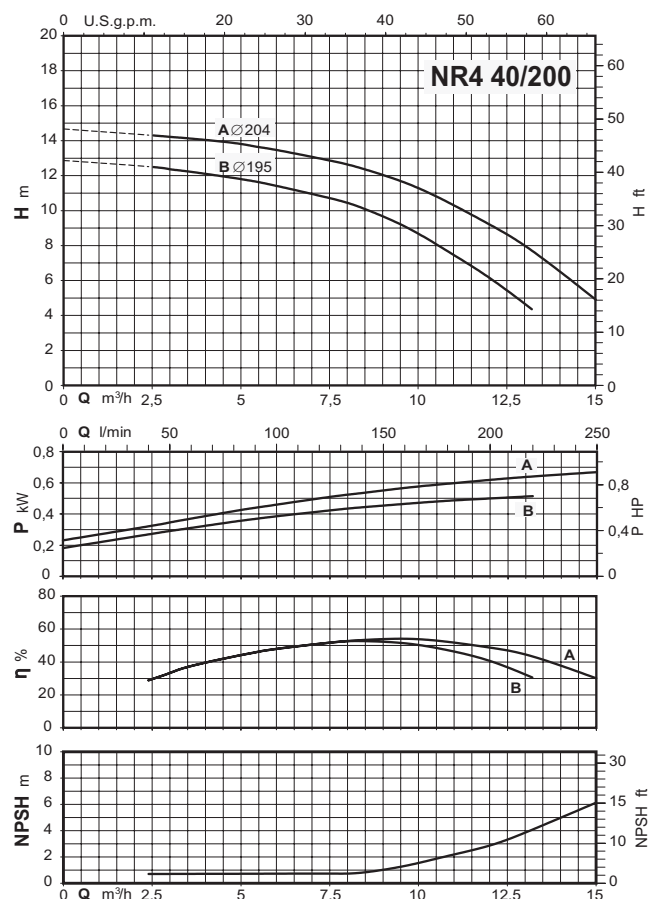
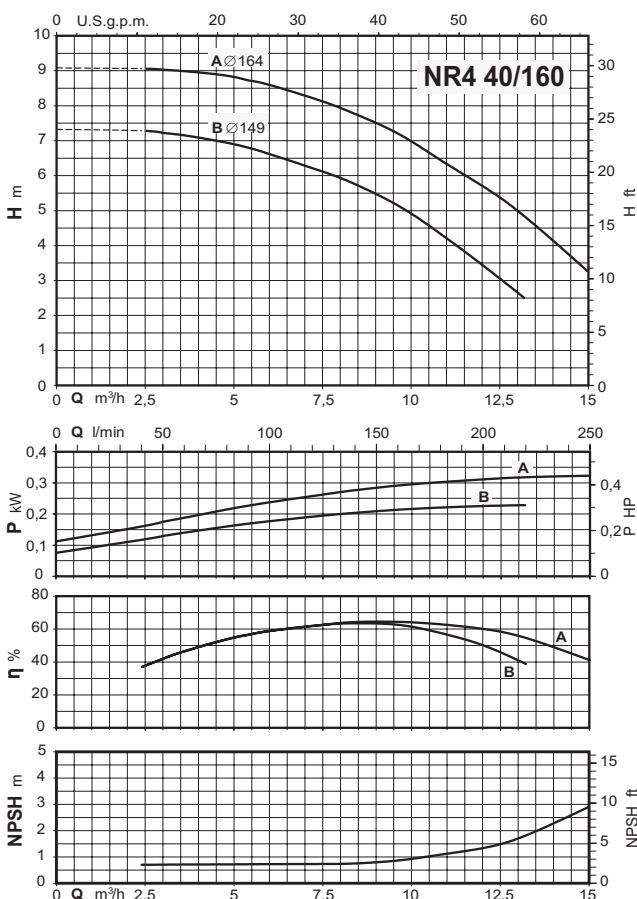
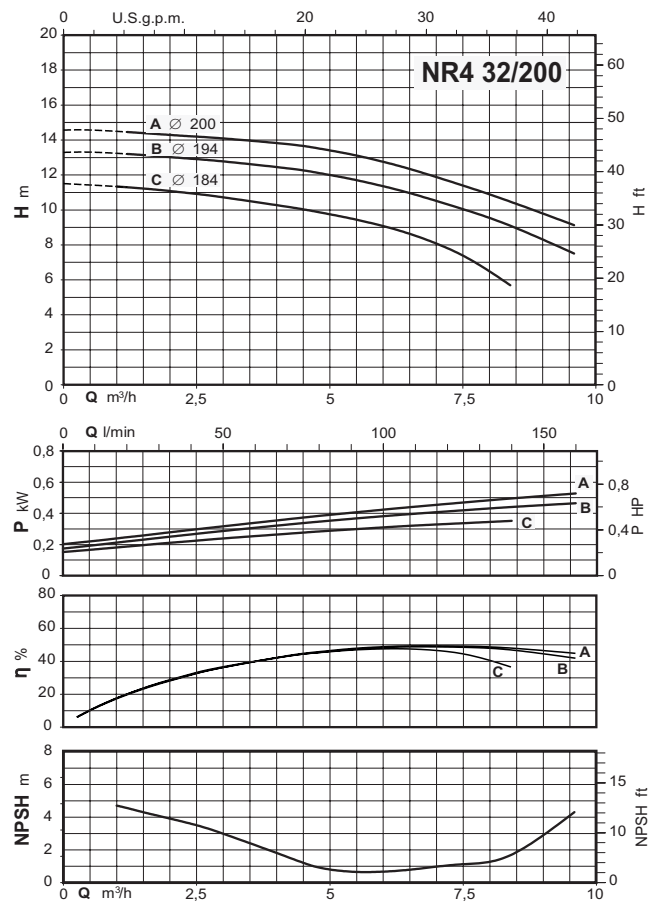
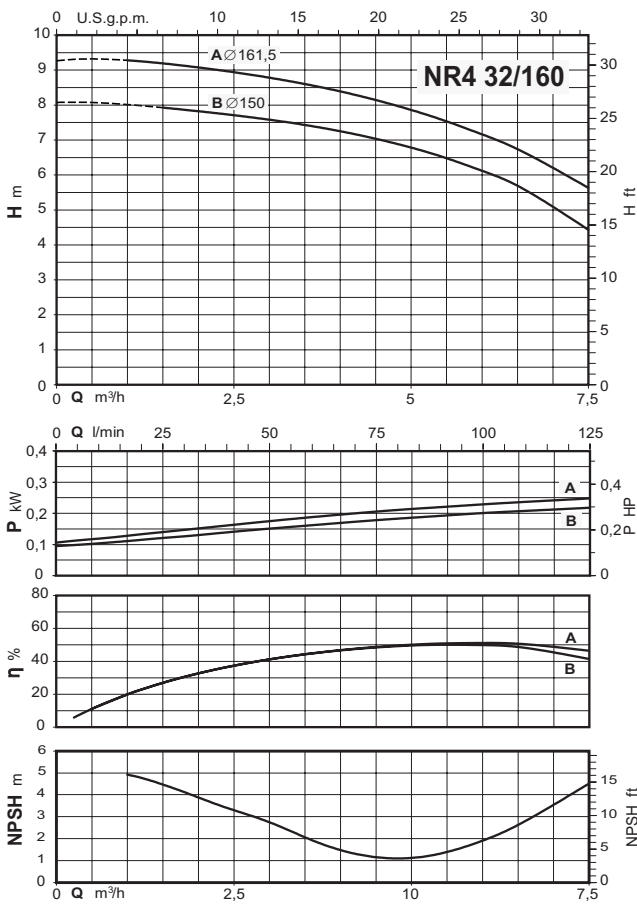

Coverage chart $n \approx 1450$ rpm

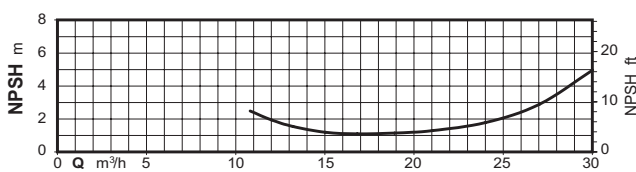
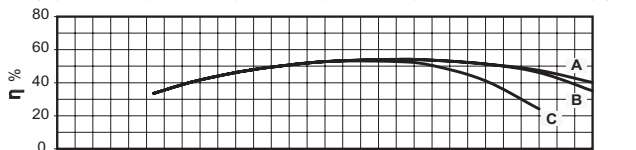
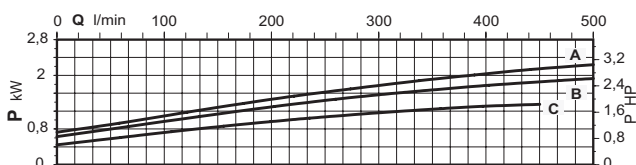
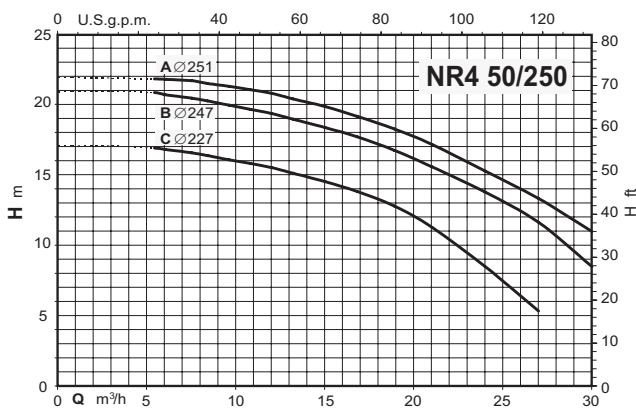
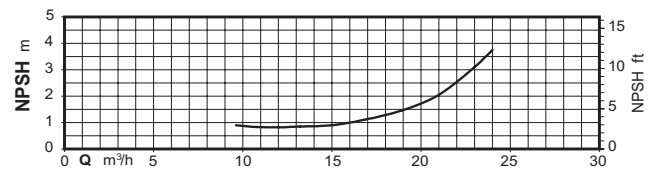
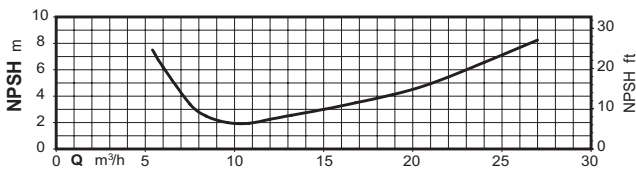
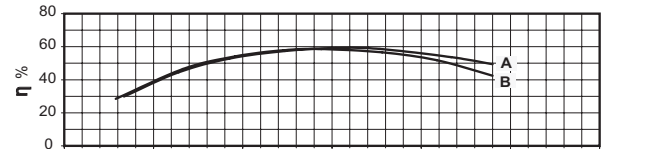
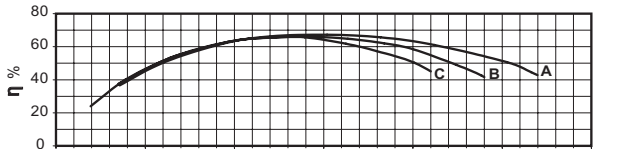
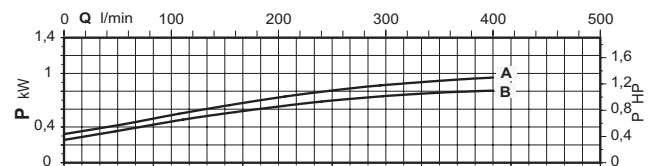
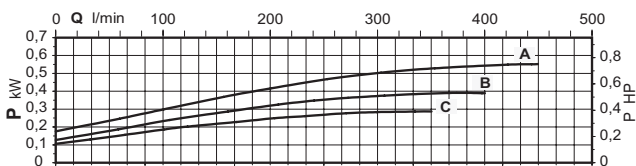
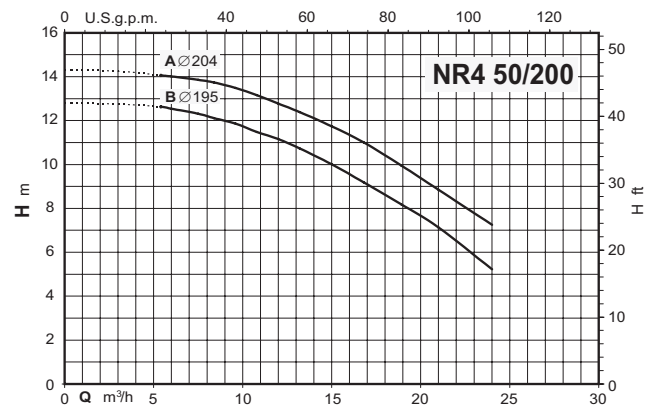
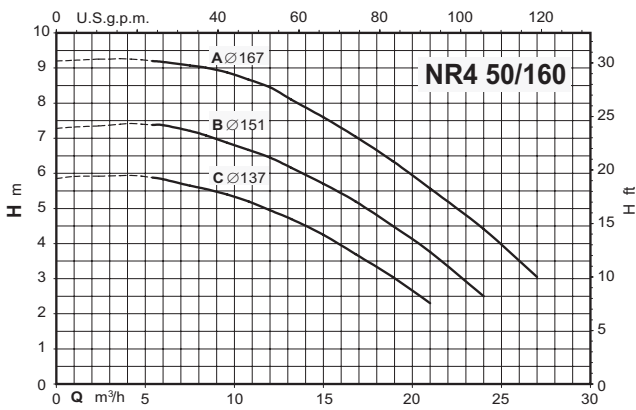

Coverage chart $n \approx 1450$ rpm

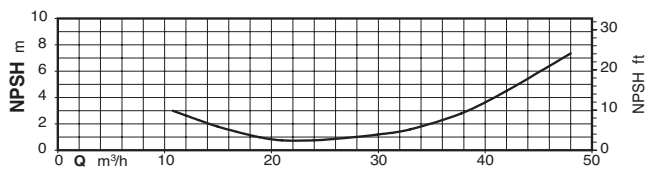
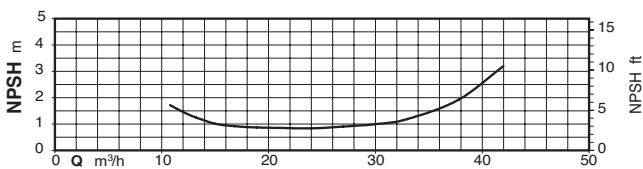
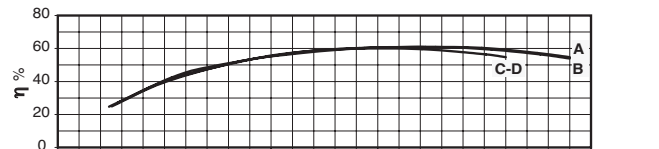
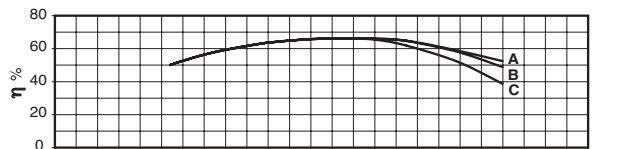
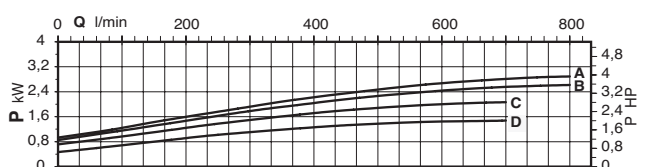
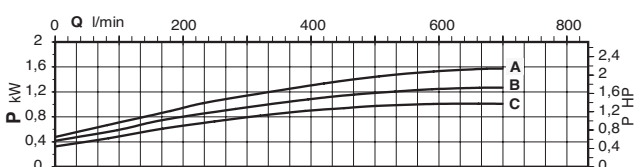
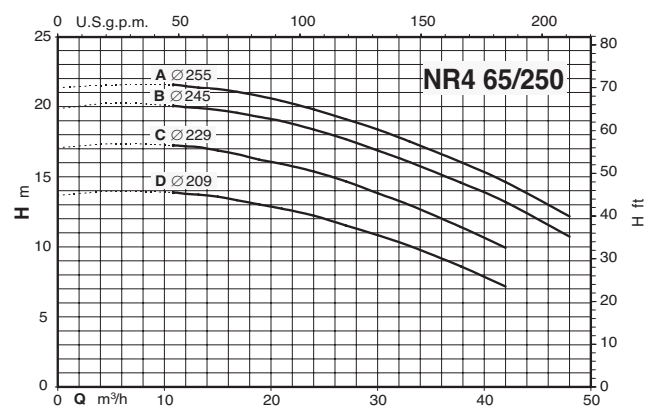
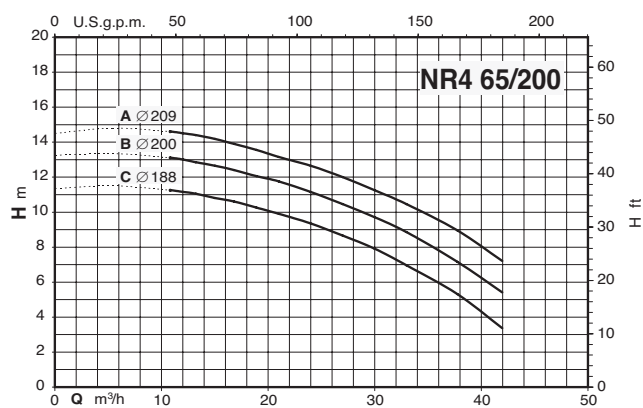
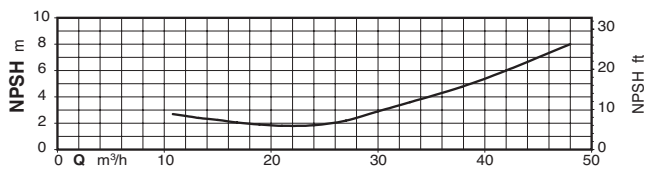
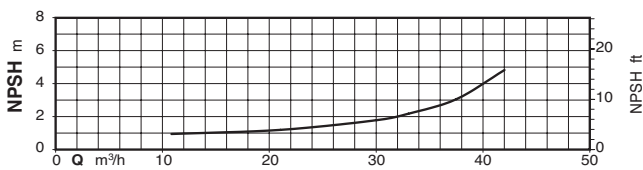
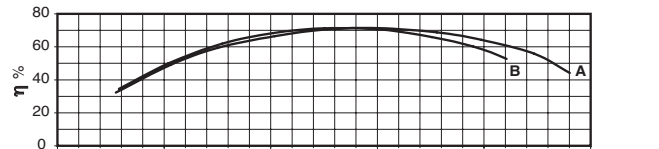
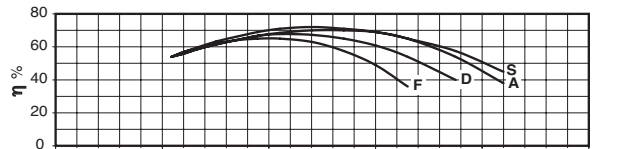
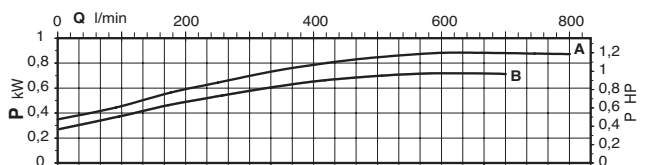
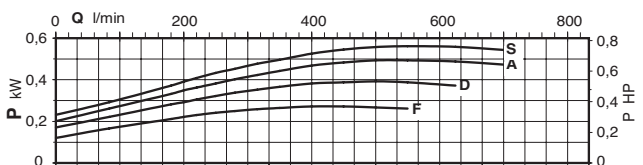
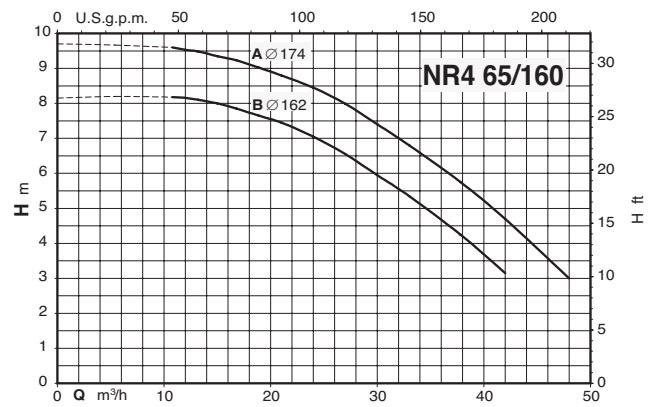
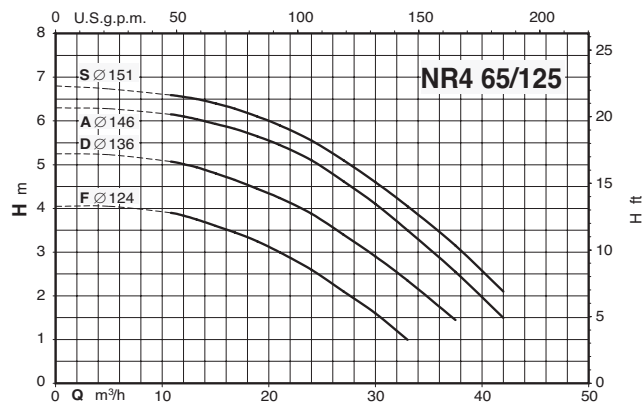

Coverage chart $n \approx 1450$ rpm

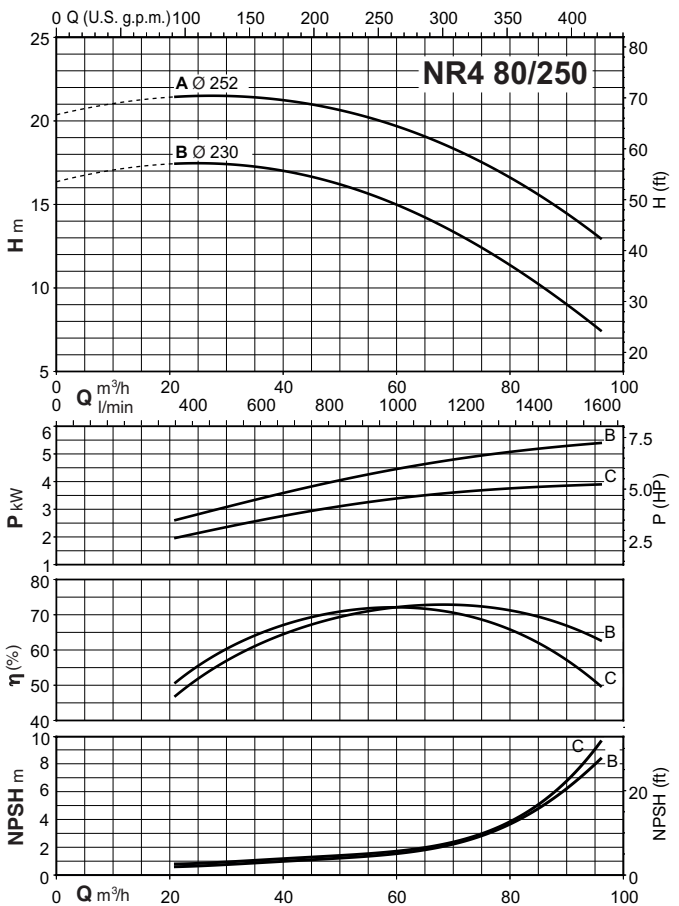
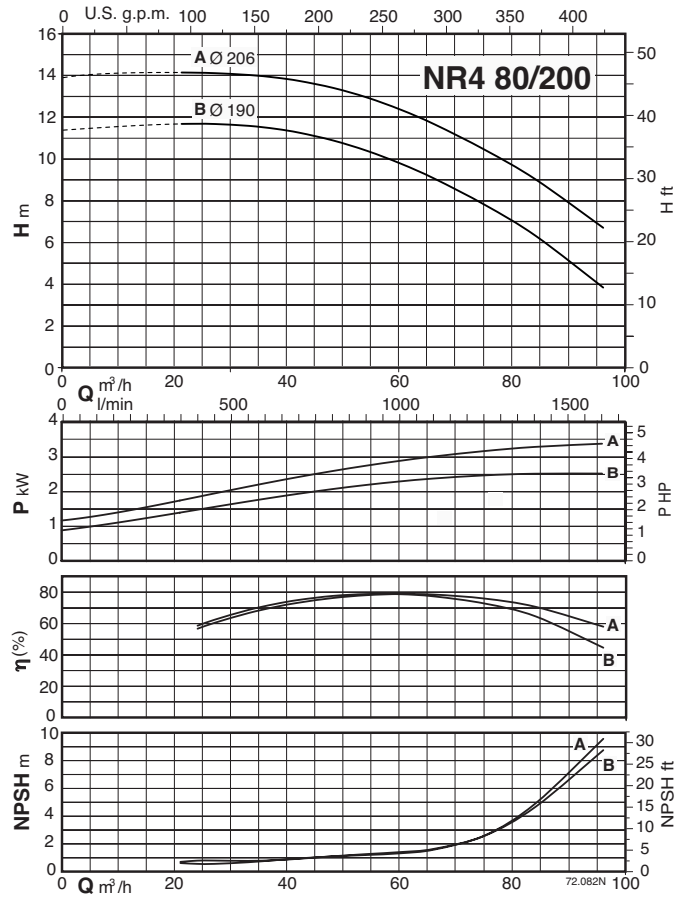
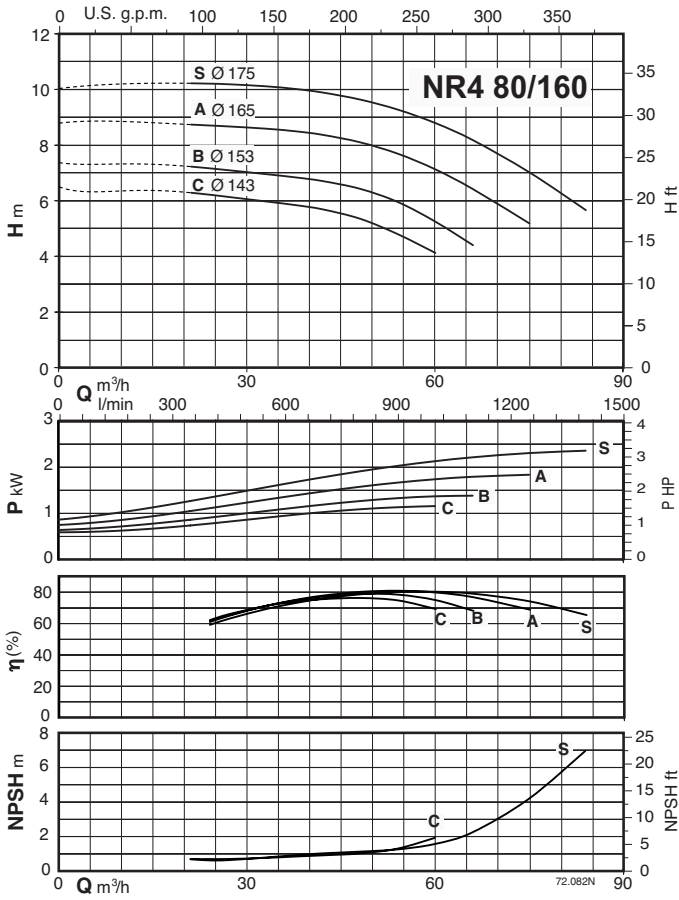

NR, NRS



Coverage chart $n \approx 1450$ rpm

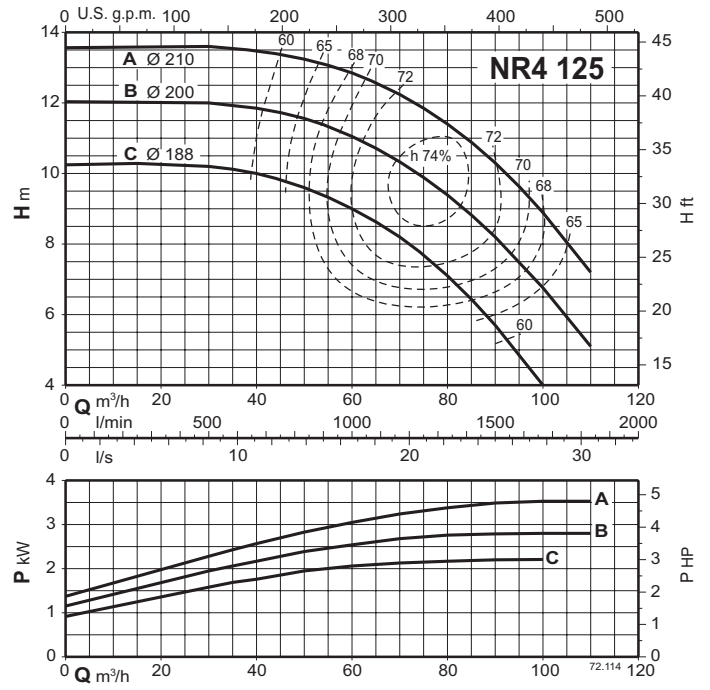
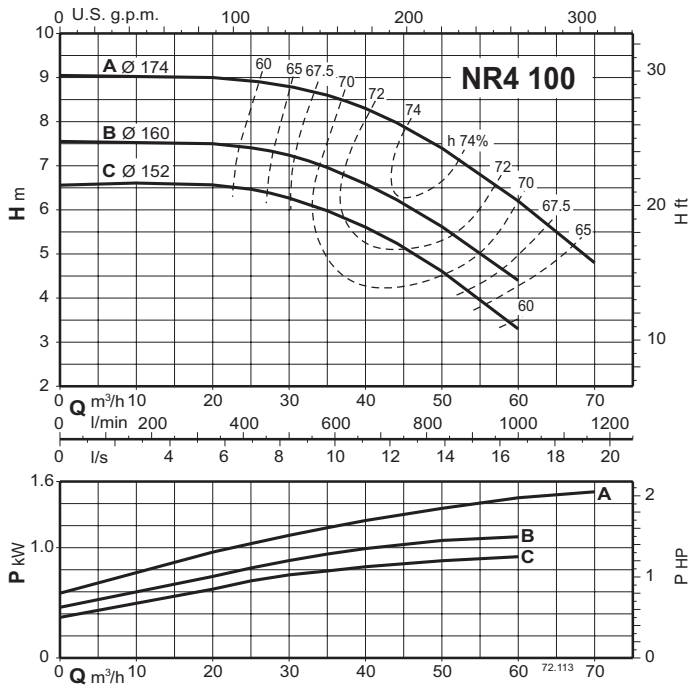

Coverage chart $n \approx 2900$ rpm

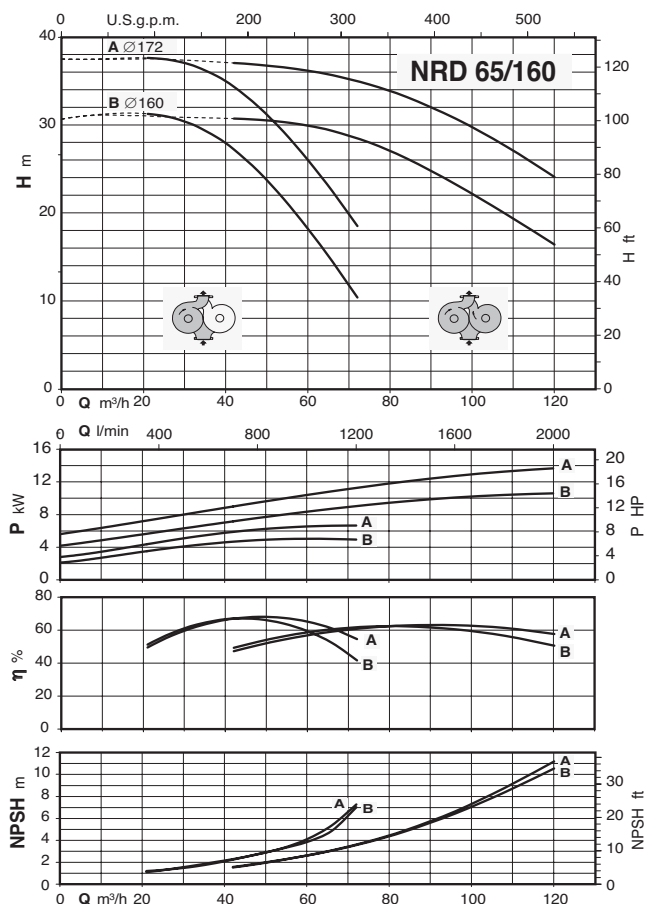
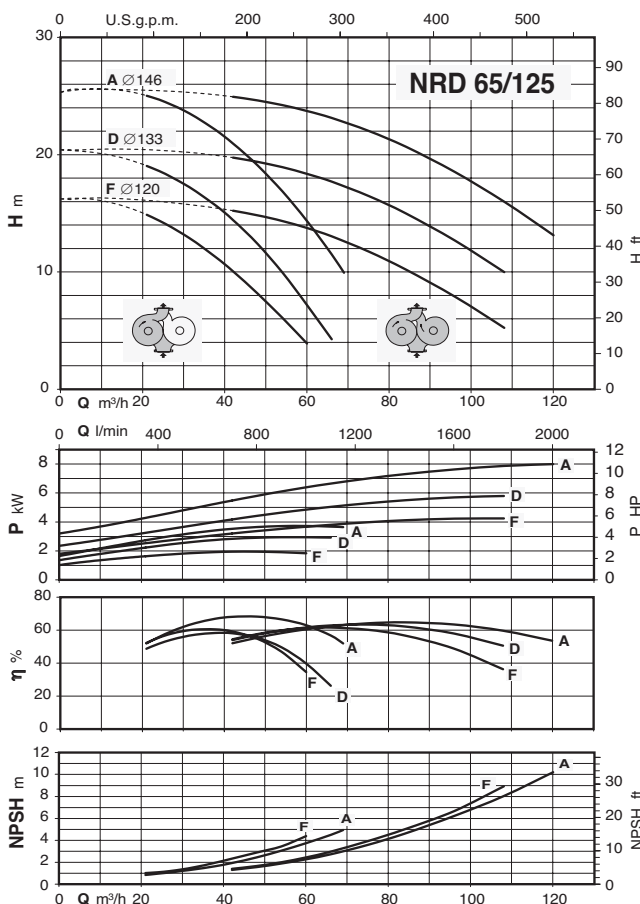
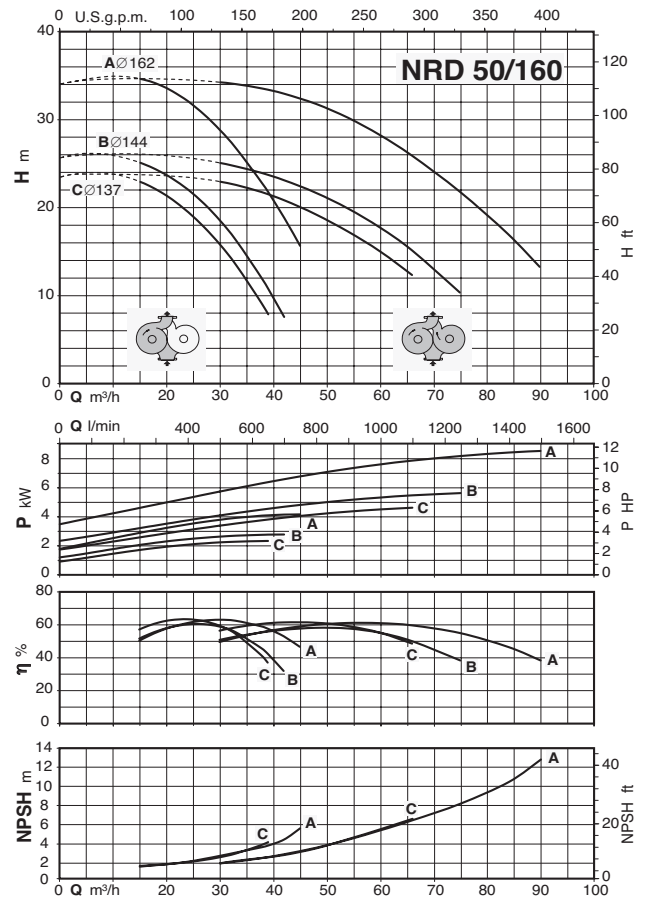
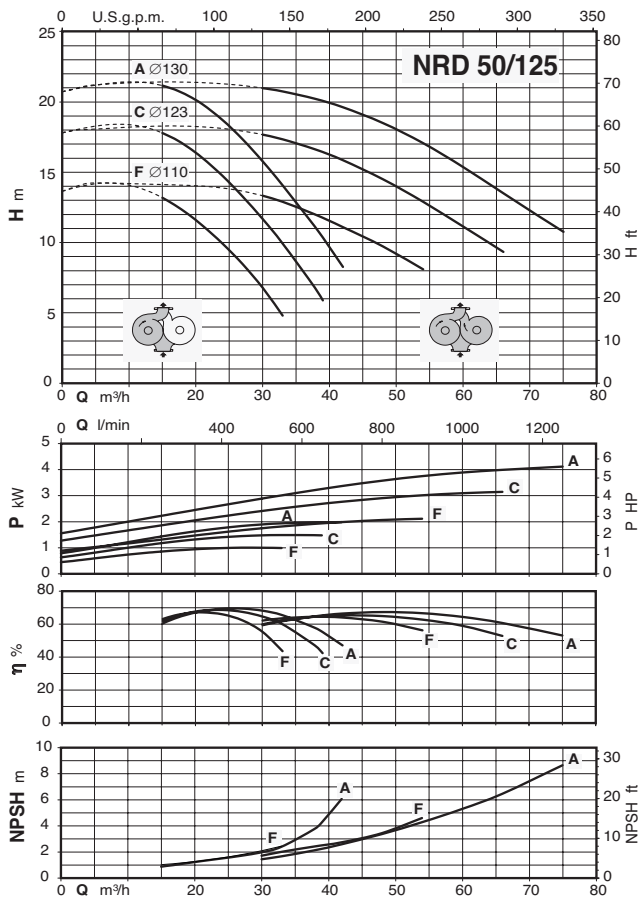

Coverage chart $n \approx 1450$ rpm

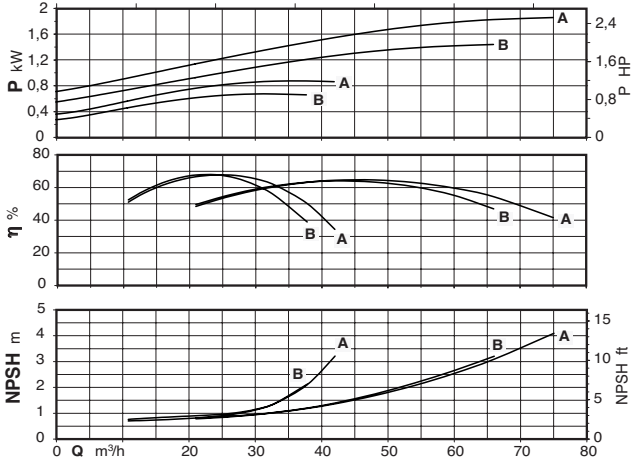
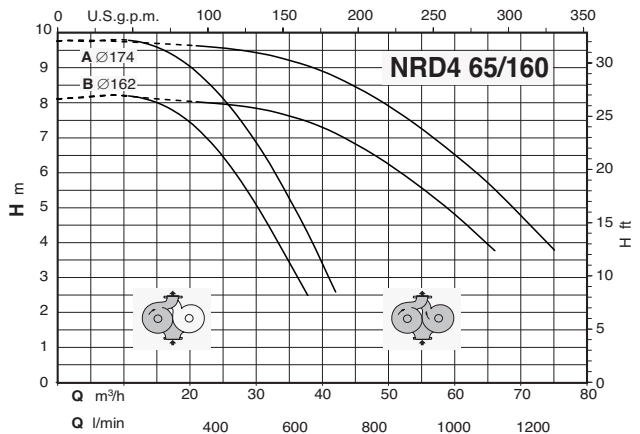
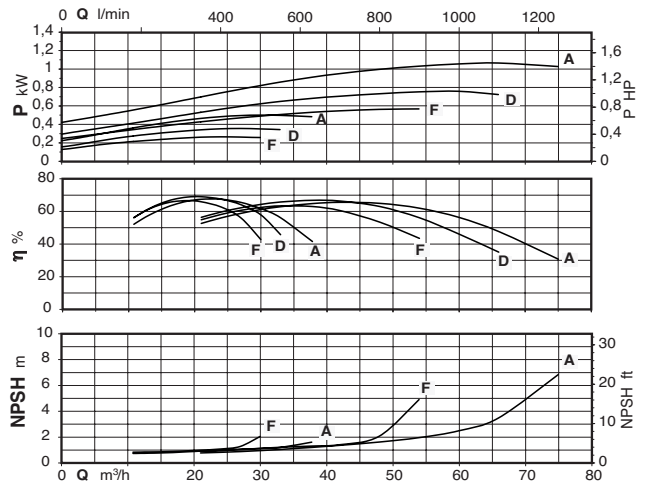
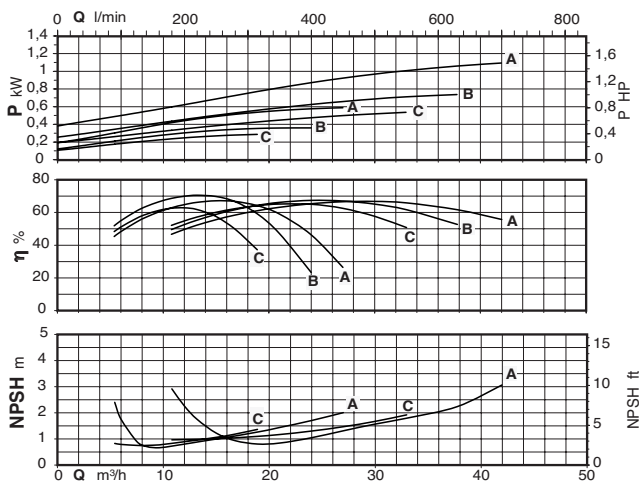
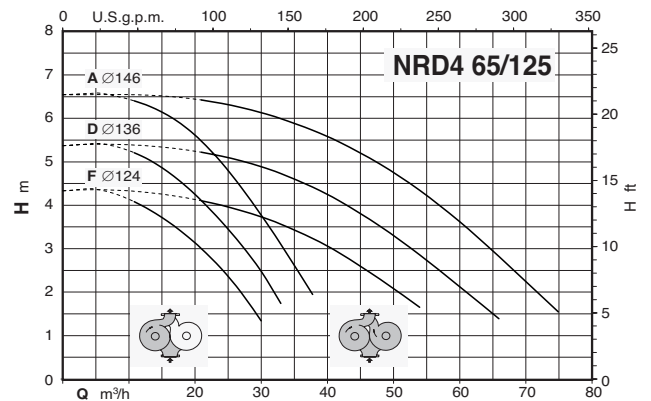
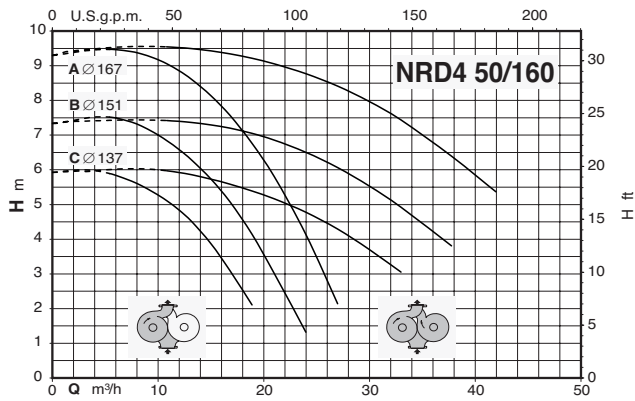

NR, NRS



Dimensions and weights

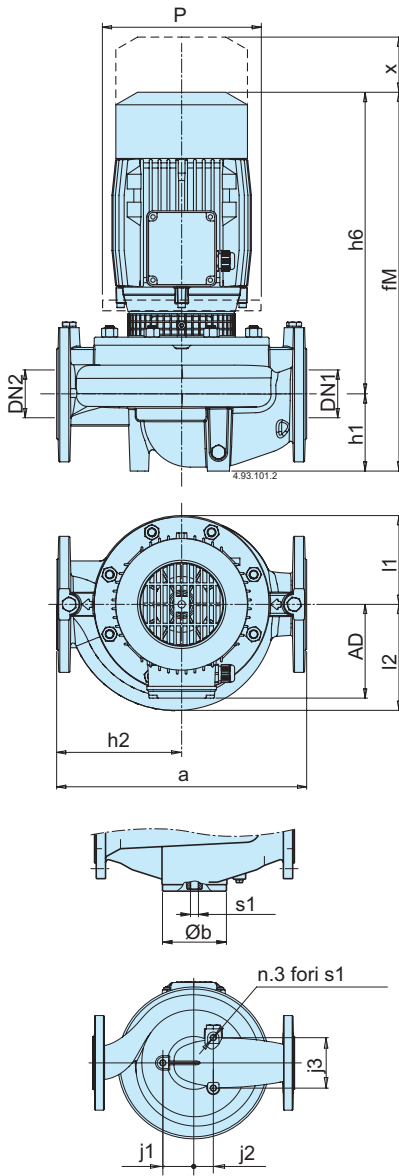

TYPE	mm		mm															kg
	DN1	DN2	a	AD	b	fM	h1	h2	h6	j1	j2	j3	l1	l2	P	s1	x	
NR 50D/A	50	50	320	113	98	363.5	90	160	273.5	-	-	-	93	100	-	M16	70	20.9
NR 50C/B	50	50	320	113	98	363.5	90	160	273.5	-	-	-	93	100	-	M16	70	24.1
NR 32/125B	32	32	260	113	-	351	80	130	271	49.5	31.5	70.5	86	88	-	M10	60	17.2
NR 32/125A	32	32	260	113	-	351	80	130	271	49.5	31.5	70.5	86	88	-	M10	60	18.7
NR 32/160B/A	32	32	340	130	-	421	80	170	341	50	40	76	102	102	-	M10	60	26.4
NR 32/160A/A	32	32	340	130	-	421	80	170	341	50	40	76	102	102	-	M10	60	28.1
NR 32/200B/A	32	32	440	130	-	469	85	220	384	60	44	84	126	126	-	M10	60	36.4
NR 32/200A	32	32	440	140	-	495	85	220	410	60	44	84	126	126	-	M10	60	43
NR 32/200S/A	32	32	440	140	-	495	85	220	410	60	44	84	126	126	-	M10	60	-
NR 40/125C	40	40	320	130	-	423	81	160	342	49	31	80	93	98	-	M10	70	25.5
NR 40/125B/A	40	40	320	130	-	423	81	160	342	49	31	80	93	98	-	M10	70	27.5
NR 40/125A/A	40	40	320	130	-	423	81	160	342	49	31	80	93	98	-	M10	70	28.8
NR 40/160B/A	40	40	320	130	-	430	81	160	349	49	31	80	119	119	-	M10	75	33.7
NR 40/160A/A	40	40	320	130	-	470	81	160	389	49	31	80	119	119	-	M10	75	37.8
NR 40/200B	40	40	440	140	-	496	81	220	415	62	40	95	140	140	-	M10	75	52.2
NR 40/200A/A	40	40	440	140	-	496	81	220	415	62	40	95	140	140	-	M10	75	55.5
NR 50/125F/A	50	50	340	130	-	437	90	170	347	45	40	79	96	115	-	M10	75	30.9
NR 50/125C/A	50	50	340	130	-	437	90	170	347	45	40	79	96	115	-	M10	75	32.6
NR 50/125A/B	50	50	340	130	-	477	90	170	387	45	40	79	96	115	-	M10	75	37.1
NR 50/160C/B	50	50	340	130	-	480	90	170	390	45	40	79	120	128	-	M10	75	39.3
NR 50/160B/A	50	50	340	140	-	506	90	170	416	45	40	79	120	128	-	M10	75	45.8
NR 50/160A/B	50	50	340	140	-	506	90	170	416	45	40	79	120	128	-	M10	75	49.3
NR 50/200D/B	50	50	440	140	-	515	100	220	415	45	40	79	140	140	-	M10	80	56.2
NR 50/200B/A	50	50	440	167	-	575.5	100	220	475.5	45	40	79	140	140	-	M10	80	69.5
NR 50/200A/A	50	50	440	167	-	575.5	100	220	475.5	45	40	79	140	140	-	M10	80	74.4
NR 50/250C/B	50	50	440	190	-	656	100	220	556	45	40	79	175	175	-	M10	85	-
NR 50/250B/A	50	50	440	190	-	656	100	220	556	45	40	79	175	175	-	M10	85	120.3
NR 50/250A/B	50	50	440	190	-	731	100	220	631	45	40	79	175	175	-	M10	85	139.7
NR 65/125F/B	65	65	340	130	-	494	105	170	389	60	50	110	121	145	-	M10	95	44.8
NR 65/125D/A	65	65	340	140	-	519	105	170	414	60	50	110	121	145	-	M10	95	51
NR 65/125A/B	65	65	340	140	-	519	105	170	414	60	50	110	121	145	-	M10	95	54.2
NR 65/125S/B	65	65	340	140	-	519	105	170	414	60	50	110	121	145	-	M10	95	54.4
NR 65/160B/A	65	65	340	167	-	583.5	105	170	478.5	60	50	110	121	142	-	M10	95	68.5
NR 65/160A/A	65	65	340	167	-	583.5	105	170	478.5	60	50	110	121	142	-	M10	95	73.5
NR 65/200B/B	65	65	475	190	-	665	105	237.5	560	60	50	110	140	153	-	M10	90	109.4
NR 65/200A/A	65	65	475	190	-	665	105	237.5	560	60	50	110	140	153	-	M10	90	117.3
NR 65/200S/B	65	65	475	190	-	740	105	237.5	635	60	50	110	140	153	-	M10	90	136.2
NR 65/250C/A	65	65	475	190	-	670	105	237.5	565	60	50	110	175	175	-	M10	90	128
NR 65/250B/B	65	65	475	190	-	745	105	237.5	640	60	50	110	175	175	-	M10	90	-
NR 65/250A/C	65	65	475	208	-	791	105	237.5	686	60	50	110	175	175	-	M10	90	-
NR 80/125E	80	80	440	140	-	533	105	220	428	85	42.5	147.2	129	152	-	M10	105	60.4
NR 80/125C	80	80	440	167	-	594.5	105	220	489.5	85	42.5	147.2	129	152	-	M10	105	74.5
NR 80/125A	80	80	440	167	-	594.5	105	220	489.5	85	42.5	147.2	129	152	-	M10	105	79.4
NR 80/160D	80	80	440	167	-	604.5	120	220	484.5	85	42.5	147.2	138	159	-	M10	105	81.2
NR 80/160C	80	80	440	190	-	684	120	220	564	85	42.5	147.2	138	159	-	M10	105	-
NR 80/160B	80	80	440	190	-	684	120	220	564	85	42.5	147.2	138	159	-	M10	105	114.1
NR 80/160AR	80	80	440	190	-	759	120	220	639	85	42.5	147.2	138	159	-	M10	105	132.5
NR 80/160A	80	80	440	190	-	759	120	220	639	85	42.5	147.2	138	159	-	M10	105	-
NR 80/200C	80	80	500	190	-	792	150	250	642	85	42.5	147.2	156	177	-	M10	105	144.7
NR 80/200B	80	80	500	208	-	843	150	250	693	85	42.5	147.2	156	177	-	M10	105	-
NR 80/200A	80	80	500	208	-	843	150	250	693	85	42.5	147.2	156	177	-	M10	105	-
NR 80/250C	80	80	620	208	-	846	150	310	696	85	42.5	147.2	179	192	-	M10	120	-
NRS 80/250B	80	80	620	300	-	1138	150	310	988	85	42.5	147.2	179	192	400	M10	120	-
NRS 80/250A	80	80	620	300	-	1138	150	310	988	85	42.5	147.2	179	192	400	M10	120	-

Flanges EN 1092-2

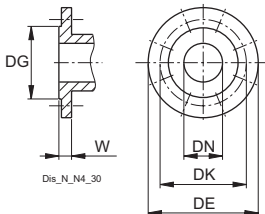

DN	PN	mm				Holes		W
		DG	DK	DE	N°	ø		
32	10-16	76	100	140	4	19	18	
40	10-16	84	110	150	4	19	18	
50	10-16	99	125	165	4	19	20	
65	10-16	118	145	185	4	19	20	
80	10-16	132	160	200	8	19	22	
100	10-16	156	180	220	8	19	24	
125	10-16	184	210	250	8	19	24	

TYPE	mm		mm															kg
	DN1	DN2	a	AD	b	fM	h1	h2	h6	j1	j2	j3	l1	l2	s1	x	Weight	
NRM 50D/A	50	50	320	113	98	363.5	90	160	273.5	-	-	-	93	100	M16	70	22.2	
NRM 50C/A	50	50	320	113	98	363.5	90	160	273.5	-	-	-	93	100	M16	70	24.1	
NRM 32/125B	32	32	260	113	-	351	80	130	271	49.5	31.5	70.5	86	88	M10	60	17.5	
NRM 32/125A	32	32	260	113	-	351	80	130	271	49.5	31.5	70.5	86	88	M10	60	18.5	
NRM 32/160B	32	32	340	130	-	421	80	170	341	50	40	76	102	102	M10	60	27.8	
NRM 32/160A	32	32	340	130	-	421	80	170	341	50	40	76	102	102	M10	60	28.4	
NRM 40/125C	40	40	320	130	-	423	81	160	342	49	31	80	93	98	M10	70	-	
NRM 40/125B	40	40	320	130	-	423	81	160	342	49	31	80	93	98	M10	70	28.7	
NRM 40/125A	40	40	320	130	-	423	81	160	342	49	31	80	93	98	M10	70	29.3	
NRM 40/160B	40	40	320	130	-	430	81	160	349	49	31	80	119	119	M10	75	34.6	
NRM 50/125F	50	50	340	130	-	437	90	170	347	45	40	79	96	115	M10	75	-	
NRM 50/125C	50	50	340	130	-	437	90	170	347	45	40	79	96	115	M10	75	32.3	

Dimensions and weights

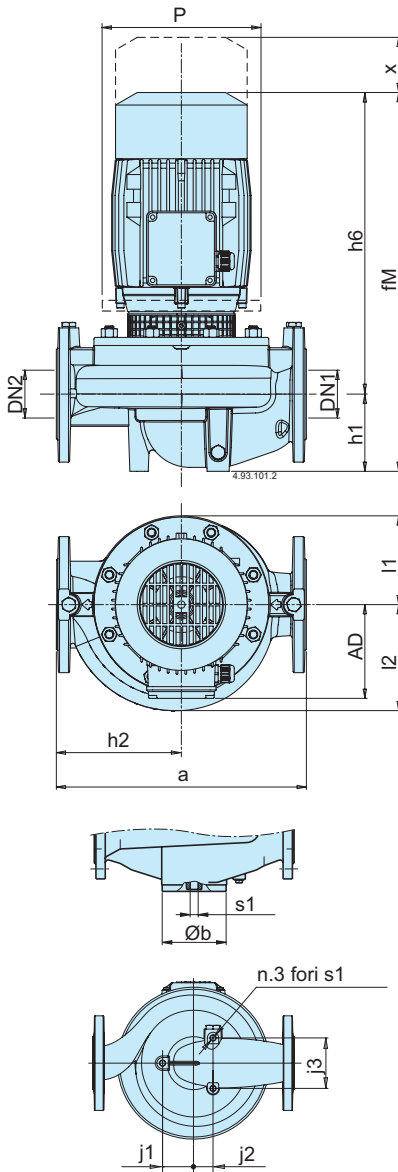

TYPE			mm													kg	
	DN1	DN2	a	AD	b	fM	h1	h2	h6	j1	j2	j3	l1	l2	s1		x
NR4 50C/A	50	50	320	113	98	363.5	90	160	273.5	-	-	-	93	100	M16	70	22
NR4 50B/A	50	50	320	113	98	363.5	90	160	273.5	-	-	-	93	100	M16	70	21.9
NR4 50A/A	50	50	320	113	98	363.5	90	160	273.5	-	-	-	93	100	M16	70	21.9
NR4 65C/A	65	65	360	113	118	373.5	100	180	273.5	-	-	-	102	114	M16	70	-
NR4 65B/A	65	65	360	113	118	373.5	100	180	273.5	-	-	-	102	114	M16	70	26.6
NR4 65A/A	65	65	360	113	118	373.5	100	180	273.5	-	-	-	102	114	M16	70	27
NR4 100C/B	100	100	500	140	162	548	150	250	398	-	-	-	153	173	M16	105	66.4
NR4 100B/B	100	100	500	140	162	548	150	250	398	-	-	-	153	173	M16	105	66
NR4 100A/B	100	100	500	140	162	548	150	250	398	-	-	-	153	173	M16	105	69.8
NR4 125C/B	125	125	600	167	194	639.5	170	300	469.5	-	-	-	172	195	M16	120	100.4
NR4 125B/A	125	125	600	167	194	639.5	170	300	469.5	-	-	-	172	195	M16	120	100.2
NR4 125A/A	125	125	600	167	194	639.5	170	300	469.5	-	-	-	172	195	M16	120	107.4
NR4 32/160B/A	32	32	340	130	-	421	80	170	341	50	40	76	102	102	M10	60	24
NR4 32/160A/A	32	32	340	130	-	421	80	170	341	50	40	76	102	102	M10	60	24.2
NR4 32/200C/A	32	32	440	130	-	426	85	220	341	60	44	84	126	126	M10	60	29.4
NR4 32/200B/A	32	32	440	130	-	426	85	220	341	60	44	84	126	126	M10	60	31.4
NR4 32/200A/A	32	32	440	130	-	466	85	220	381	60	44	84	126	126	M10	60	36.5
NR4 40/160B/A	40	40	320	130	-	430	81	160	349	49	31	80	119	119	M10	75	30.5
NR4 40/160A/A	40	40	320	130	-	430	81	160	349	49	31	80	119	119	M10	75	30.7
NR4 40/200B/A	40	40	440	130	-	430	81	220	349	62	40	95	140	140	M10	75	40.1
NR4 40/200A/A	40	40	440	130	-	470	81	220	389	62	40	95	140	140	M10	75	45.6
NR4 50/160C/A	50	50	340	130	-	440	90	170	350	45	40	79	120	128	M10	75	32.3
NR4 50/160B/A	50	50	340	130	-	440	90	170	350	45	40	79	120	128	M10	75	33.9
NR4 50/160A/B	50	50	340	130	-	480	90	170	390	45	40	79	120	128	M10	75	39.3
NR4 50/200B/B	50	50	440	140	-	515	100	220	415	45	40	79	140	140	M10	80	52.2
NR4 50/200A/B	50	50	440	140	-	515	100	220	415	45	40	79	140	140	M10	80	52.6
NR4 50/250C/B	50	50	440	140	-	516	100	220	416	45	40	79	175	175	M10	85	68.8
NR4 50/250B/B	50	50	440	167	-	576.5	100	220	476.5	45	40	79	175	175	M10	85	81.5
NR4 50/250A/A	50	50	440	167	-	576.5	100	220	476.5	45	40	79	175	175	M10	85	81.9
NR4 65/125F/A	65	65	340	130	-	454	105	170	349	60	50	110	121	145	M10	95	37.5
NR4 65/125D/A	65	65	340	130	-	454	105	170	349	60	50	110	121	145	M10	95	39.3
NR4 65/125A/B	65	65	340	130	-	494	105	170	389	60	50	110	121	145	M10	95	44.7
NR4 65/125S/B	65	65	340	130	-	494	105	170	389	60	50	110	121	145	M10	95	45
NR4 65/160B/B	65	65	340	140	-	522	105	170	417	60	50	110	121	142	M10	95	50.2
NR4 65/160A/B	65	65	340	140	-	522	105	170	417	60	50	110	121	142	M10	95	50.4
NR4 65/200C/B	65	65	475	140	-	535	105	237.5	430	60	50	110	140	153	M10	90	60
NR4 65/200B/B	65	65	475	140	-	535	105	237.5	430	60	50	110	140	153	M10	90	63.4
NR4 65/200A/B	65	65	475	167	-	585.5	105	237.5	480.5	60	50	110	140	153	M10	90	74.1
NR4 65/250D/B	65	65	475	167	-	585.5	105	237.5	480.5	60	50	110	175	175	M10	90	-
NR4 65/250C/B	65	65	475	167	-	585.5	105	237.5	480.5	60	50	110	175	175	M10	90	86.4
NR4 65/250B/A	65	65	475	167	-	585.5	105	237.5	480.5	60	50	110	175	175	M10	90	-
NR4 65/250A/A	65	65	475	167	-	585.5	105	237.5	480.5	60	50	110	175	175	M10	90	94.1
NR4 80/160C	80	80	440	140	-	543	120	220	423	85	42.5	147.2	138	159	M10	105	58
NR4 80/160B	80	80	440	140	-	543	120	220	423	85	42.5	147.2	138	159	M10	105	57.8
NR4 80/160A	80	80	440	140	-	543	120	220	423	85	42.5	147.2	138	159	M10	105	61.8
NR4 80/160S	80	80	440	167	-	604.5	120	220	484.5	85	42.5	147.2	138	159	M10	105	73.4
NR4 80/200B	80	80	500	167	-	637.5	150	250	487.5	85	42.5	147.2	156	177	M10	105	82.3
NR4 80/200A	80	80	500	167	-	637.5	150	250	487.5	85	42.5	147.2	156	177	M10	105	82.5
NR4 80/250B	80	80	620	167	-	656	150	310	506	85	42.5	147.2	179	192	M10	120	-
NR4 80/250A	80	80	620	190	-	725	150	310	575	85	42.5	147.2	179	192	M10	120	-

TYPE			mm													kg
	DN1	DN2	a	AD	b	fM	h1	h2	h6	l1	l2	s1	x	Weight		
NR4M 50C/A	50	50	320	113	98	363.5	90	160	273.5	93	100	M16	70	-		
NR4M 50B/A	50	50	320	113	98	363.5	90	160	273.5	93	100	M16	70	23.5		
NR4M 50A/A	50	50	320	113	98	363.5	90	160	273.5	93	100	M16	70	23.5		
NR4M 65C/A	65	65	360	113	118	373.5	100	180	273.5	102	114	M16	70	-		

Flanges EN 1092-2

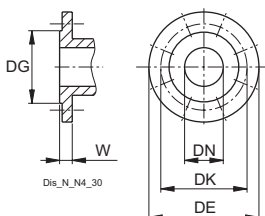

DN	PN	DG	DK	DE	Holes		W
					N°	ø	
					32	10-16	
40	10-16	84	110	150	4	19	18
50	10-16	99	125	165	4	19	20
65	10-16	118	145	185	4	19	20
80	10-16	132	160	200	8	19	22
100	10-16	156	180	220	8	19	24
125	10-16	184	210	250	8	19	24

Dimensions and weights

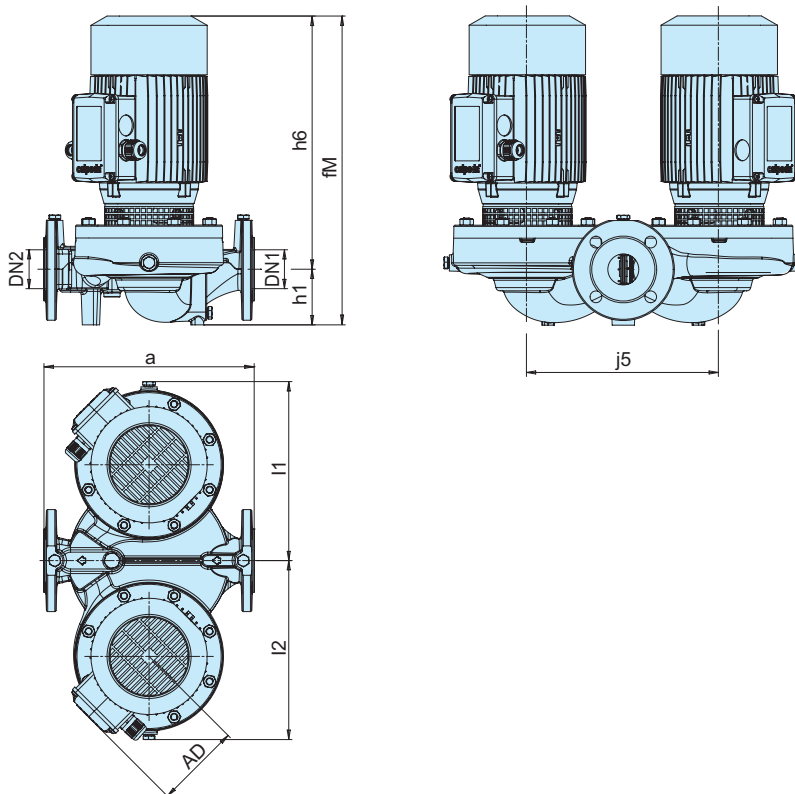

TYPE	DN1	DN2	mm								kg
			a	AD	fM	h1	h6	j5	l1	l2	Weight
NRD 50/125F	50	50	340	130	433.5	90	343.5	310	278.5	278.5	62.7
NRD 50/125C	50	50	340	130	433.5	90	343.5	310	278.5	278.5	66.2
NRD 50/125A	50	50	340	130	473.5	90	383.5	310	278.5	278.5	72
NRD 50/160C	50	50	340	130	473.5	90	383.5	310	291.5	291.5	79
NRD 50/160B	50	50	340	139	499.5	90	409.5	310	291.5	291.5	91.8
NRD 50/160A	50	50	340	139	499.5	90	409.5	310	291.5	291.5	101.5
NRD 65/125F	65	65	340	128	488.5	105	383.5	310	303.5	303.5	86.8
NRD 65/125D	65	65	340	138	514.5	105	409.5	310	303.5	303.5	99.6
NRD 65/125A	65	65	340	138	514.5	105	409.5	310	303.5	303.5	106.2
NRD 65/160B	65	65	340	160	543.5	105	438.5	310	303.5	303.5	-
NRD 65/160A	65	65	340	160	543.5	105	438.5	310	303.5	303.5	147.5

TYPE	DN1	DN2	mm								kg
			a	AD	fM	h1	h6	j5	l1	l2	Weight
NRD4 50/160C	50	50	340	130	433.5	90	343.5	310	291.5	291.5	65.5
NRD4 50/160B	50	50	340	130	433.5	90	343.5	310	291.5	291.5	69.2
NRD4 50/160A	50	50	340	130	473.5	90	383.5	310	291.5	291.5	79.5
NRD4 65/125F	65	65	340	130	448.5	105	343.5	310	303.5	303.5	-
NRD4 65/125D	65	65	340	130	448.5	105	343.5	310	303.5	303.5	76.3
NRD4 65/125A	65	65	340	130	488.5	105	383.5	310	303.5	303.5	87.5
NRD4 65/160B	65	65	340	138	514.5	105	409.5	310	303.5	303.5	-
NRD4 65/160A	65	65	340	138	514.5	105	409.5	310	303.5	303.5	-

Flanges EN 1092-2

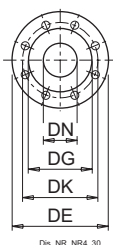

DN	PN	DG	DK	DE	Holes		W
					N°	ø	
					32	10-16	
40	10-16	84	110	150	4	19	18
50	10-16	99	125	165	4	19	20
65	10-16	118	145	185	4	19	20
80	10-16	132	160	200	8	19	22
100	10-16	156	180	220	8	19	24
125	10-16	184	210	250	8	19	24

Dimensions and weights

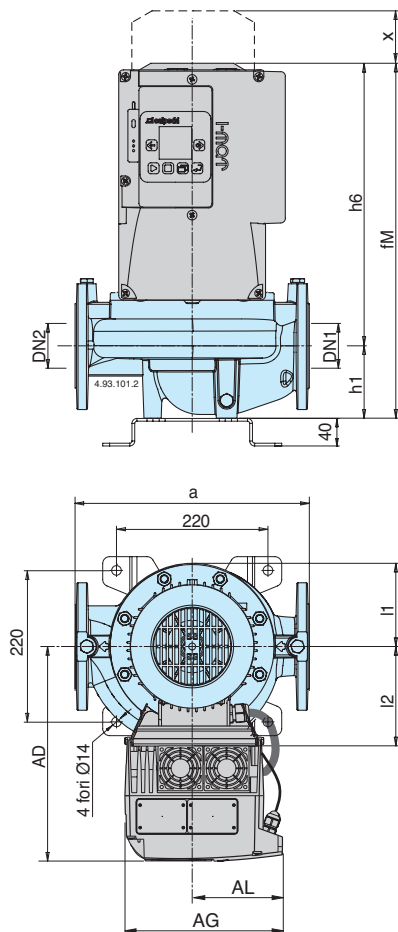

TYPE	mm		mm											kg
	DN1	DN2	a	AD	AG	AL	fM	h1	h2	h6	l1	l2	x	
NR EI 50D/A	50	50	320	266	190	105	363.5	90	160	273.5	93	100	70	29.3
NR EI 50C/B	50	50	320	266	190	105	363.5	90	160	273.5	93	100	70	32.3
NR EI 32/125B	32	32	260	266	190	105	351	80	130	271	86	88	60	24.8
NR EI 32/125A	32	32	260	266	190	105	351	80	130	271	86	88	60	-
NR EI 32/160B/A	32	32	340	285	190	105	421	80	170	341	102	102	60	35
NR EI 32/160A/A	32	32	340	285	190	105	421	80	170	341	102	102	60	36.2
NR EI 32/200B/A	32	32	440	285	210	117.5	469	85	220	384	126	126	60	-
NR EI 32/200A	32	32	440	295	210	117.5	495	85	220	410	126	126	60	52.3
NR EI 32/200S/A	32	32	440	295	210	117.5	495	85	220	410	126	126	60	-
NR EI 40/125C	40	40	320	285	190	105	423	81	160	342	93	98	70	34
NR EI 40/125B/A	40	40	320	285	190	105	423	81	160	342	93	98	70	36
NR EI 40/125A/A	40	40	320	285	190	105	423	81	160	342	93	98	70	37.4
NR EI 40/160B/A	40	40	320	285	190	105	430	81	160	349	119	119	75	42.4
NR EI 40/160A/A	40	40	320	285	210	117.5	470	81	160	389	119	119	75	47
NR EI 40/200B	40	40	440	295	210	117.5	496	81	220	415	140	140	75	64
NR EI 40/200A/A	40	40	440	295	210	117.5	496	81	220	415	140	140	75	66.7
NR EI 50/125F/A	50	50	340	285	190	105	437	90	170	347	96	115	75	39
NR EI 50/125C/A	50	50	340	285	190	105	437	90	170	347	96	115	75	40.3
NR EI 50/125A/B	50	50	340	285	210	117.5	477	90	170	387	96	115	75	47.5
NR EI 50/160C/B	50	50	340	285	210	117.5	480	90	170	390	120	128	75	49
NR EI 50/160B/A	50	50	340	295	210	117.5	506	90	170	416	120	128	75	55.2
NR EI 50/160A/B	50	50	340	295	210	117.5	506	90	170	416	120	128	75	58.8
NR EI 50/200D/B	50	50	440	295	210	117.5	515	100	220	415	140	140	80	-
NR EI 50/200B/A	50	50	440	324	210	117.5	576	100	220	476	140	140	80	-
NR EI 50/200A/A	50	50	440	366	281	153.5	576	100	220	476	140	140	80	-
NR EI 50/250C/B	50	50	440	389	281	153.5	656	100	220	556	175	175	85	-
NR EI 50/250B/A	50	50	440	389	281	153.5	656	100	220	556	175	175	85	-
NR EI 50/250A/B	50	50	440	469	350	190	731	100	220	631	175	175	85	-
NR EI 65/125F/B	65	65	340	285	210	117.5	494	105	170	389	121	145	95	53.9
NR EI 65/125D/A	65	65	340	295	210	117.5	519	105	170	414	121	145	95	60.8
NR EI 65/125A/B	65	65	340	295	210	117.5	519	105	170	414	121	145	95	64.3
NR EI 65/125S/B	65	65	340	295	210	117.5	519	105	170	414	121	145	95	63.8
NR EI 65/160B/A	65	65	340	324	210	117.5	584	105	170	479	121	142	95	74.5
NR EI 65/160A/A	65	65	340	366	281	153.5	584	105	170	479	121	142	95	90.3
NR EI 65/200B/B	65	65	475	389	281	153.5	665	105	237.5	560	140	153	90	125
NR EI 65/200A/A	65	65	475	389	281	153.5	665	105	237.5	560	140	153	90	-
NR EI 65/200S/B	65	65	475	469	350	190	740	105	237.5	635	140	153	90	-
NR EI 65/250C/A	65	65	475	389	281	153.5	670	105	237.5	565	175	175	90	-
NR EI 65/250B/B	65	65	475	469	350	190	745	105	237.5	640	175	175	90	-
NR EI 65/250A/C	65	65	475	488	350	190	791	105	237.5	686	175	175	90	-
NR EI 80/125E	80	80	440	295	210	117.5	533	105	220	428	129	152	105	-
NR EI 80/125C	80	80	440	324	210	117.5	595	105	220	490	129	152	105	84
NR EI 80/125A	80	80	440	366	281	153.5	595	105	220	490	129	152	105	-
NR EI 80/160D	80	80	440	366	281	153.5	605	120	220	485	138	159	105	-
NR EI 80/160C	80	80	440	389	281	153.5	684	120	220	564	138	159	105	-
NR EI 80/160B	80	80	440	389	281	153.5	684	120	220	564	138	159	105	-
NR EI 80/160A	80	80	440	469	350	190	759	120	220	639	138	159	105	-
NR EI 80/160AR	80	80	440	469	350	190	759	120	220	639	138	159	105	-
NR EI 80/200C	80	80	500	469	350	190	792	150	250	642	156	177	105	-
NR EI 80/200B	80	80	500	488	350	190	843	150	250	693	156	177	105	-
NR EI 80/200A	80	80	500	488	350	190	843	150	250	693	156	177	105	-
NR EI 80/250C	80	80	620	488	350	190	846	150	310	696	179	192	120	-

Flanges EN 1092-2

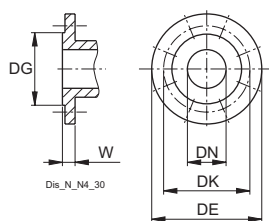

DN	PN	DG	DK	DE	Holes		W
					N°	ø	
					mm	mm	
32	10-16	76	100	140	4	19	18
40	10-16	84	110	150	4	19	18
50	10-16	99	125	165	4	19	20
65	10-16	118	145	185	4	19	20
80	10-16	132	160	200	8	19	22
100	10-16	156	180	220	8	19	24
125	10-16	184	210	250	8	19	24

Dimensions and weights

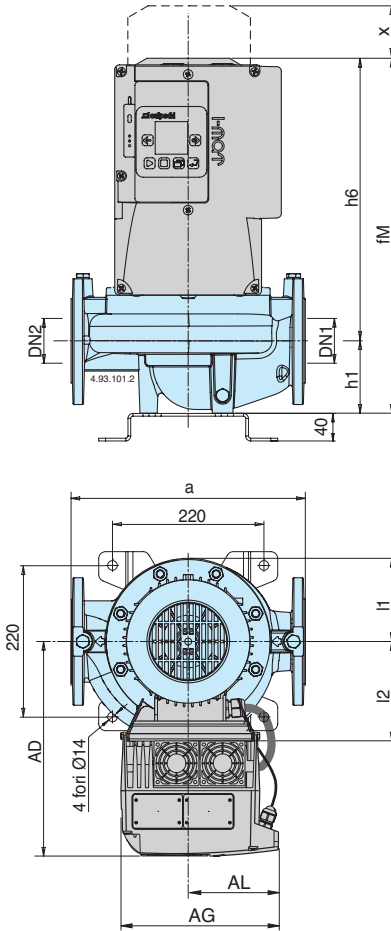

TYPE	mm		mm											kg
	DN1	DN2	a	AD	AG	AL	fM	h1	h2	h6	l1	l2	x	
NR4 EI 50C/A	50	50	320	266	190	105	363.5	90	160	273.5	93	100	70	-
NR4 EI 50B/A	50	50	320	266	190	105	363.5	90	160	273.5	93	100	70	-
NR4 EI 50A/A	50	50	320	266	190	105	363.5	90	160	273.5	93	100	70	-
NR4 EI 65C/A	65	65	360	266	190	105	373.5	100	180	273.5	102	114	70	-
NR4 EI 65B/A	65	65	360	266	190	105	373.5	100	180	273.5	102	114	70	-
NR4 EI 65A/A	65	65	360	266	190	105	373.5	100	180	273.5	102	114	70	37
NR4 EI 100C/B	100	100	500	295	190	105	548	150	250	398	153	173	105	-
NR4 EI 100B/B	100	100	500	295	190	105	548	150	250	398	153	173	105	76
NR4 EI 100A/B	100	100	500	295	190	105	548	150	250	398	153	173	105	-
NR4 EI 125C/B	125	125	600	324	210	117.5	640	170	300	470	172	195	120	112
NR4 EI 125B/A	125	125	600	324	210	117.5	640	170	300	470	172	195	120	112
NR4 EI 125A/A	125	125	600	324	210	117.5	640	170	300	470	172	195	120	-
NR4 EI 32/160B/A	32	32	340	285	190	105	421	80	170	341	102	102	60	34.6
NR4 EI 32/160A/A	32	32	340	285	190	105	421	80	170	341	102	102	60	-
NR4 EI 32/200C/A	32	32	440	285	190	105	426	85	220	341	126	126	60	-
NR4 EI 32/200B/A	32	32	440	285	190	105	426	85	220	341	126	126	60	-
NR4 EI 32/200A/A	32	32	440	285	190	105	466	85	220	381	126	126	60	-
NR4 EI 40/160B/A	40	40	320	285	190	105	430	81	160	349	119	119	75	40
NR4 EI 40/160A/A	40	40	320	285	190	105	430	81	160	349	119	119	75	-
NR4 EI 40/200B/A	40	40	440	285	190	105	430	81	220	349	140	140	75	-
NR4 EI 40/200A/A	40	40	440	285	190	105	470	81	220	389	140	140	75	-
NR4 EI 50/160C/A	50	50	340	285	190	105	440	90	170	350	120	128	75	-
NR4 EI 50/160B/A	50	50	340	285	190	105	440	90	170	350	120	128	75	-
NR4 EI 50/160A/B	50	50	340	285	190	105	480	90	170	390	120	128	75	48.1
NR4 EI 50/200B/B	50	50	440	295	190	105	515	100	220	415	140	140	80	-
NR4 EI 50/200A/B	50	50	440	295	190	105	515	100	220	415	140	140	80	-
NR4 EI 50/250C/B	50	50	440	295	190	105	516	100	220	416	175	175	85	77.3
NR4 EI 50/250B/B	50	50	440	324	210	117.5	577	100	220	477	175	175	85	93.5
NR4 EI 50/250A/A	50	50	440	324	210	117.5	577	100	220	477	175	175	85	-
NR4 EI 65/125F/A	65	65	340	285	190	105	454	105	170	349	121	145	95	-
NR4 EI 65/125D/A	65	65	340	285	190	105	454	105	170	349	121	145	95	-
NR4 EI 65/125A/B	65	65	340	285	190	105	494	105	170	389	121	145	95	-
NR4 EI 65/125S/B	65	65	340	285	190	105	494	105	170	389	121	145	95	54
NR4 EI 65/160B/B	65	65	340	295	190	105	522	105	170	417	121	142	95	-
NR4 EI 65/160A/B	65	65	340	295	190	105	522	105	170	417	121	142	95	59
NR4 EI 65/200C/B	65	65	475	295	190	105	535	105	237.5	430	140	153	90	-
NR4 EI 65/200B/B	65	65	475	295	190	105	535	105	237.5	430	140	153	90	-
NR4 EI 65/200A/B	65	65	475	324	210	117.5	586	105	237.5	481	140	153	90	-
NR4 EI 65/250D/B	65	65	475	324	210	117.5	586	105	237.5	481	175	175	90	-
NR4 EI 65/250C/B	65	65	475	324	210	117.5	586	105	237.5	481	175	175	90	-
NR4 EI 65/250B/A	65	65	475	324	210	117.5	586	105	237.5	481	175	175	90	-
NR4 EI 65/250A/A	65	65	475	324	210	117.5	586	105	237.5	481	175	175	90	108
NR4 EI 80/160C	80	80	440	295	190	105	543	120	220	423	138	159	105	-
NR4 EI 80/160B	80	80	440	295	190	105	543	120	220	423	138	159	105	-
NR4 EI 80/160A	80	80	440	295	190	105	543	120	220	423	138	159	105	-
NR4 EI 80/160S	80	80	440	324	210	117.5	605	120	220	485	138	159	105	-
NR4 EI 80/200B	80	80	500	324	210	117.5	638	150	250	488	156	177	105	-
NR4 EI 80/200A	80	80	500	324	210	117.5	638	150	250	488	156	177	105	-
NR4 EI 80/250B	80	80	620	324	210	117.5	656	150	310	506	179	192	120	-
NR4 EI 80/250A	80	80	620	389	281	153.5	725	150	310	575	179	192	120	-

Flanges EN 1092-2

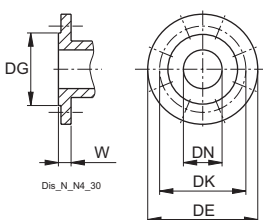

DN	PN	DG	mm					W
			DK	DE	Holes			
					N°	ø		
32	10-16	76	100	140	4	19	18	
40	10-16	84	110	150	4	19	18	
50	10-16	99	125	165	4	19	20	
65	10-16	118	145	185	4	19	20	
80	10-16	132	160	200	8	19	22	
100	10-16	156	180	220	8	19	24	
125	10-16	184	210	250	8	19	24	

Dimensions and weights

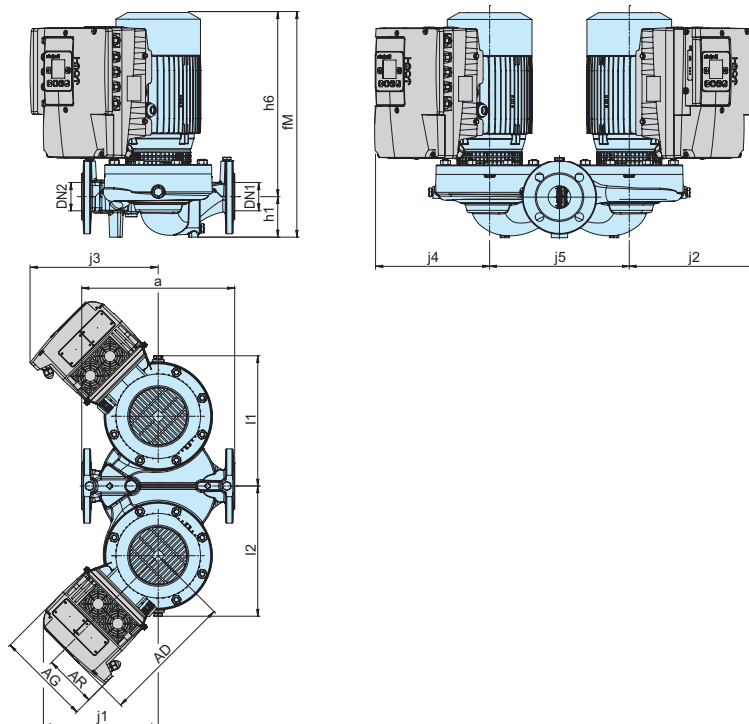

TYPE			mm														kg
	DN1	DN2	a	AD	AG	AR	fM	h1	h6	j1	j2	j3	j4	j5	l1	l2	Weight
NRD EI 50/125F	50	50	340	284	190	105	433.5	90	343.5	243	269	269	243	310	278.5	278.5	78.6
NRD EI 50/125C	50	50	340	284	190	105	433.5	90	343.5	243	269	269	243	310	278.5	278.5	79.5
NRD EI 50/125A	50	50	340	284	210	118	473.5	90	383.5	249	277	277	249	310	278.5	278.5	90.8
NRD EI 50/160C	50	50	340	284	210	118	473.5	90	383.5	249	277	277	249	310	291.5	291.5	94.7
NRD EI 50/160B	50	50	340	293	210	118	499.5	90	409.5	256	283	283	256	310	291.5	291.5	108.5
NRD EI 50/160A	50	50	340	293	210	118	499.5	90	409.5	256	283	283	256	310	291.5	291.5	117
NRD EI 65/125F	65	65	340	284	210	118	488.5	105	383.5	249	277	277	249	310	303.5	303.5	102.3
NRD EI 65/125D	65	65	340	293	210	118	514.5	105	409.5	256	283	283	256	310	303.5	303.5	118.5
NRD EI 65/125A	65	65	340	293	210	118	514.5	105	409.5	256	283	283	256	310	303.5	303.5	122.6
NRD EI 65/160B	65	65	340	364	283	156	543.5	105	438.5	274	304	304	274	310	303.5	303.5	158
NRD EI 65/160A	65	65	340	364	283	156	543.5	105	438.5	331	358	358	331	310	303.5	303.5	177.5

TYPE			mm														kg
	DN1	DN2	a	AD	AG	AR	fM	h1	h6	j1	j2	j3	j4	j5	l1	l2	Weight
NRD4 EI 50/160C	50	50	340	284	190	105	433.5	90	343.5	243	269	269	243	310	291.5	291.5	-
NRD4 EI 50/160B	50	50	340	284	190	105	433.5	90	343.5	243	269	269	243	310	291.5	291.5	-
NRD4 EI 50/160A	50	50	340	284	190	105	473.5	90	383.5	243	269	269	243	310	291.5	291.5	-
NRD4 EI 65/125F	65	65	340	284	190	105	448.5	105	343.5	243	269	269	243	310	303.5	303.5	-
NRD4 EI 65/125D	65	65	340	284	190	105	448.5	105	343.5	243	269	269	243	310	303.5	303.5	90.5
NRD4 EI 65/125A	65	65	340	284	190	105	488.5	105	383.5	243	269	269	243	310	303.5	303.5	-
NRD4 EI 65/160B	65	65	340	293	190	105	514.5	105	409.5	250	75	75	249	310	303.5	303.5	-
NRD4 EI 65/160A	65	65	340	293	190	105	514.5	105	409.5	250	75	75	249	310	303.5	303.5	-

Flanges EN 1092-2

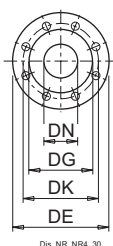

DN	PN	DG	DK	DE	Holes		W
					N°	ø	
					mm		
32	10-16	76	100	140	4	19	18
40	10-16	84	110	150	4	19	18
50	10-16	99	125	165	4	19	20
65	10-16	118	145	185	4	19	20
80	10-16	132	160	200	8	19	22
100	10-16	156	180	220	8	19	24
125	10-16	184	210	250	8	19	24

Installation

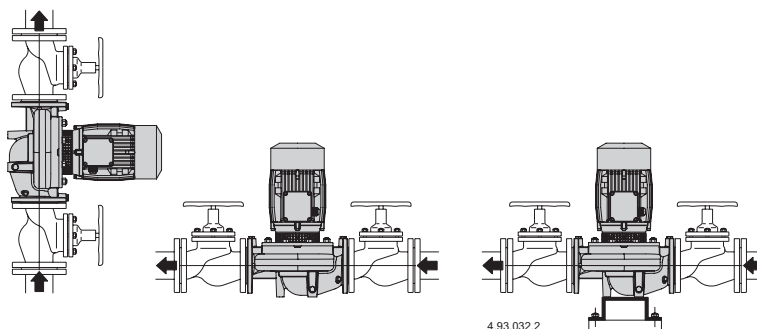

4.93.032.2